

Final Report

BHE Downeast Reliability Project

Steady State and Short Circuit Analyses

For I.3.9 Approval

May, 2005

Prepared by:



Engineering & Environmental Consulting

Table of Contents

Executive Summary	iii
1 Introduction	1
1.1 Background.....	1
1.2 Recommended Project	2
2 Study Approach	3
2.1 Base Case Development	3
2.1.1 Base Case Origin, Year and Load Levels	3
2.1.2 Base Case Modifications.....	3
2.1.3 Generation Dispatch and Interface Transfers	4
2.1.4 MIS Online System Operation.....	4
2.2 System Performance Criteria.....	5
2.2.1 Steady State Thermal Limits.....	5
2.2.2 Steady State Voltage Limits.....	5
2.3 Contingency List for Thermal and Voltage Analysis.....	6
2.3.1 Special Contingency Modeling Considerations.....	6
3 Discussion of Steady State Analysis and Results.....	7
3.1 Reliability Improvement for the Downeast Region Transmission System	8
3.1.1 Baseline System Performance.....	8
3.1.2 BHE Downeast Reliability Project System Performance	8
3.2 Local Area Issues – No Adverse Impact.....	9
4 Discussion of Short Circuit Analysis and Results.....	9
5 Conclusions	10

Appendices

- APPENDIX A – Interface and Dispatch Summaries
- APPENDIX B – Base Case Draw Files
- APPENDIX C – Contingency Descriptions
- APPENDIX D – Contingency Analysis Thermal Results
- APPENDIX E – Contingency Analysis Voltage Results
- APPENDIX F – Short-Circuit Analysis Results

List of Tables

Table 2.1 - Steady State Thermal Loading Criteria	5
Table 2.2 - Steady State Voltage Criteria	5
Table 2.3 - Contingency List for Thermal and Voltage Analysis.....	6

List of Figures

Figure 1.1 – Geographical Map of Study Area.....	1
Figure 1.2 – Schematic Representation of the Study Area	2

Executive Summary

Bangor Hydro Electric (BHE) proposes to build new 115-kV transmission originating from a tap, 6 miles from Boggy Brook on Line 61, to Harrington Substation and upgrade the 115-kV Epping Substation. The BHE Downeast Reliability Project will provide a loop feed from BHE's transmission system to Deblois, Epping, Harrington, and Washington County Substations. This loop will improve transmission service reliability to load and generation customers in BHE's Downeast region. The in-service date for the project is planned for December, 2009.

The purpose of this study was to analyze the BHE Downeast Reliability Project and assure that it posed no significant adverse impact on the reliability and operating characteristics of the interconnected bulk power transmission system in accordance with the ISO New England Planning Procedure No. 5-3, "*Guidelines for Conducting and Evaluating Proposed Plan Application Analysis*".

Steady state thermal and voltage analyses examined 2009 summer peak (29,090 MW) and 2009 summer light (14,490 MW) NEPOOL load levels. Two generation dispatch patterns were represented for each load level to stress system conditions. The 2009 summer peak NEPOOL load level was also analyzed with the Northeast Reliability Interconnection Project (NRI) in-service as a sensitivity. Steady state and short circuit testing compared area transmission reliability performance for the baseline system and the system with the BHE Downeast Reliability Project. Short circuit testing was also analyzed with the NRI Project in-service as a sensitivity.

The results of the steady state analysis are discussed in Section 3 and demonstrate improved reliability for the BHE Downeast region transmission system. The results of the short circuit analysis, performed by BHE, indicate that increases in fault current contributions will not exceed equipment interrupting capabilities. These results are discussed in Section 4.

The BHE Downeast Reliability Project posed no significant adverse impact on the reliability and operating characteristics of the interconnected bulk power transmission system.

1 Introduction

1.1 Background

The Downeast Area of Bangor Hydro Electric’s (BHE) transmission system currently consists of a portion of looped 115-kV transmission into Boggy Brook Substation in Ellsworth (Lines 60, 66 and 67) and radial 115-kV transmission, Line 66, from Rebel Hill to Washington County (WCS) Substation. Line 66 is tapped to serve Deblois and Harrington Substations. Currently, loss of Line 66 interrupts the loop feed to Boggy Brook (Line 67) and results in isolation of the 115-kV Deblois, Epping, Harrington, and Washington County Substations.

BHE plans to improve transmission service reliability to load and generation customers in the Downeast Area by building new 115-kV transmission and upgrading the existing 115-kV Epping Substation. The Hancock County Reliability Project will improve system reliability in the Ellsworth and Trenton areas by adding new 115kV transmission from Boggy Brook to Trenton, Line 61. Additionally a new 115-kV transmission line originating from a tap, 6 miles from Boggy Brook on Line 61, to Harrington Substation provides loop feed from BHE’s transmission system to Deblois, Epping, Harrington, and Washington County Substations. The new transmission loop and the upgraded Epping Substation eliminate the isolation of 115-kV substations for loss of Line 66. Approximately mid way from the Line 61 tap to Harrington Substation this line is tapped to serve the new 115/34-kV Tunk Lake Substation.

Figures 1.1 and 1.2 below show the BHE Downeast area transmission system geographically and schematically.

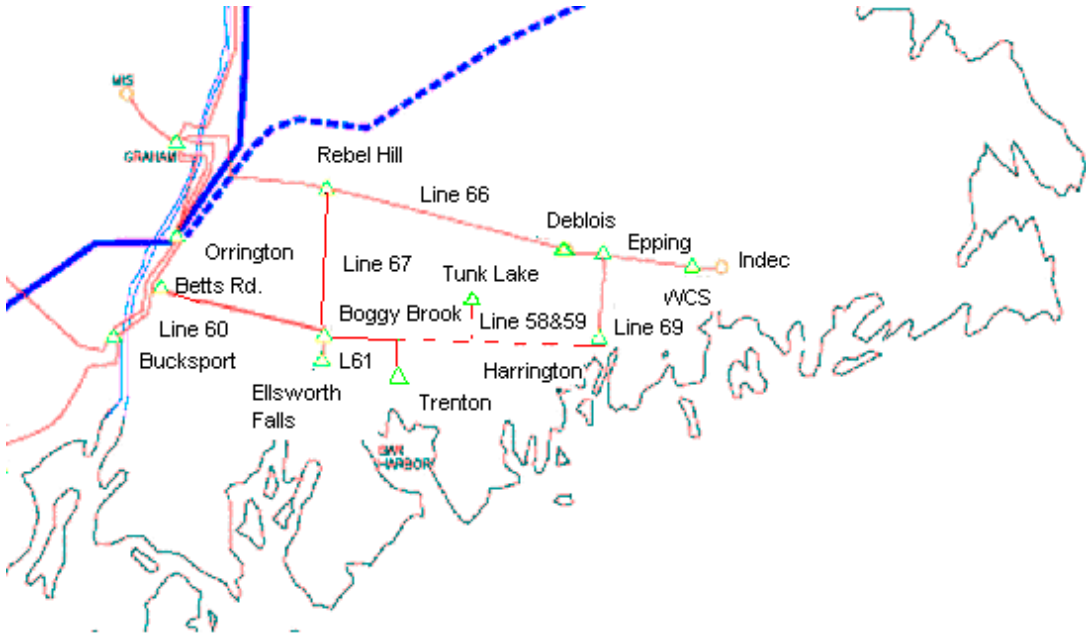

Figure 1.1 – Geographical Map of Study Area

1.2 Recommended Project

The BHE Downeast Reliability Project consists of the following activities:

- Build 35 miles of new 795 ACSR 115-kV transmission originating from a tap point on Line 61, referred to as Hancock, to Harrington Substation. Approximately mid way from Hancock to Harrington Substation this line is tapped to serve the new 115/34-kV Tunk Lake Substation. The section of line from Hancock to Tunk Lake is referred to as Line 58, and the section of line from Tunk Lake to Harrington Substation is referred to as Line 59.
- Two new 115-kV breakers will be added at Tunk Lake on Lines 58 and 59.
- Three new 115-kV breakers will be added at the Epping Substation, creating a ring bus arrangement that is readily adaptable in the future to a breaker-and-a-half configuration.

Figure 1.2 below depicts the existing transmission system, the Hancock County Reliability Project and the proposed BHE Downeast Reliability Project.

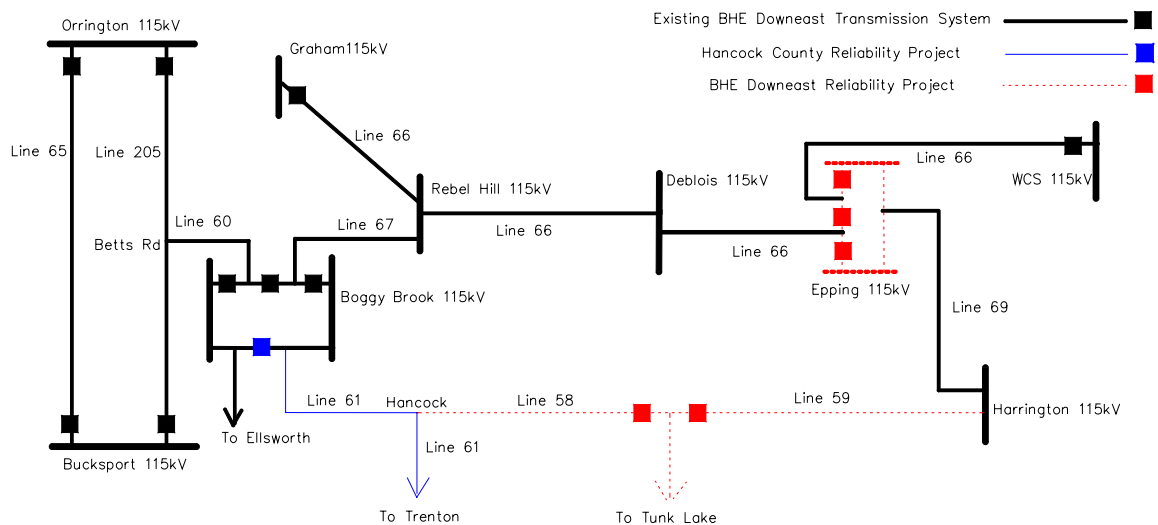

Figure 1.2 – Schematic Representation of the Study Area

2 Study Approach

This study was performed in accordance with the ISO New England Planning Procedure No. 5-3, “*Guidelines for Conducting and Evaluating Proposed Plan Application Analysis*”. The proposed BHE Downeast Reliability Project was evaluated to assure that it posed no significant adverse impact on the reliability and operating characteristics of the NEPOOL bulk power transmission system.

Steady state thermal and voltage analyses examined system performance without the proposed project in order to establish the baseline. System performance was re-evaluated with the BHE Downeast Reliability Project and compared with the previous baseline performance to demonstrate the impact of the project on area transmission reliability. This section describes the baseline and project base cases, performance criteria, and contingency list.

2.1 Base Case Development

Base cases were developed for two system configurations; one with the baseline transmission system and the other with the proposed BHE Downeast Reliability Project.

2.1.1 Base Case Origin, Year and Load Levels

Base cases were developed with a 2009 transmission system representation as requested by BHE. The choice for using this load level and base case representation was based on the Project’s planned in-service date of December, 2009.

Two load levels were represented:

1. The 2009 summer peak base case originated from the 2003 NPCC library. NEPOOL load, including losses, was increased to approximately 29,090 MW to represent an extreme weather 90/10 load forecast based on the 2004 CELT Report.
2. The 2009 summer light base case was developed from the summer peak case. NEPOOL load was scaled to represent 50% of the 2009 summer peak load. NEPOOL load, including losses, was approximately 14,490 MW.

2.1.2 Base Case Modifications

The following upgrades with 18.4 approvals are assumed in-service in the base cases:

- The reconductoring of BHE Line 66 and Line 67
- The Redington 30MW wind farm upgrade

The following reliability projects are included in the base cases. These projects do not have 18.4 approvals:

- Hancock County Reliability Project
- Y138 Line Closing Project

Many other transmission system upgrades expected to be in-service by 2009 outside the relevant area of BHE’s Downeast Reliability Project area are also included in the bases cases.

Additionally, a model of BHE's sub-transmission system is included in the base cases.

2.1.3 Generation Dispatch and Interface Transfers

Two generation dispatch patterns were used to stress system conditions for summer peak and summer light load levels. Interface and dispatch summaries can be viewed in Appendix A.

- Peak Load:
 - Maine Independent System (MIS) offline, Great Lakes Hydro (GLHA) online, Bucksport Energy (BELL) online
 - MIS online, GLHA offline, BELL online
- Light Load:
 - MIS offline, GLHA offline, BELL online
 - MIS online, GLHA offline, BELL offline

The Northeast Reliability Interconnection Project (NRI) was modeled with the 2009 summer peak load level as a sensitivity case.

Transfers on the Orrington-South interface did not exceed the thermal limit based on the summer normal rating of Section 86 (Bucksport to Highland).

The base cases and relevant results can be identified by a naming convention with the following abbreviations used to identify the status of the MIS, GLHA and BELL stations, the status of the BHE Downeast Reliability Project and the NRI Project.

- M0G1 denotes MIS offline, GLHA online, and BELL online
- M1G0 denotes MIS online, GLHA offline, and BELL online
- M0B1 denotes MIS offline, BELL online, and GLHA offline
- M1B0 denotes MIS online, BELL offline, and GLHA offline
- BHE denotes BHE Downeast Reliability Project in-service
- NRI denotes NRI Project in-service

2.2 System Performance Criteria

2.2.1 Steady State Thermal Limits

Table 2.1 below identifies the thermal criteria used for the steady state thermal assessment.

SYSTEM CONDITION	TIME INTERVAL	MAXIMUM ALLOWABLE FACILITY LOADING
Pre-contingency (all lines in)	Continuous	Normal rating
Post-contingency	Less than 15 minutes after contingency occurs	Short Time Emergency (STE) Rating ¹
	More than 15 minutes after contingency occurs	Long Time Emergency (LTE) Rating

Table 2.1 - Steady State Thermal Loading Criteria

¹ Post-contingency loading above LTE but below STE is considered acceptable as long as prompt system action (local phase shifter adjustment, generation runback, or special protection system (SPS) operation) could reduce loading below LTE within 15 minutes.

2.2.2 Steady State Voltage Limits

Table 2.2 below identifies the voltage criteria used for the steady state voltage assessment.

Voltage Level	POST-CONTINGENCY BUS VOLTAGE LIMITS	
	High Limit (pu)	Low Limit (pu)
345-kV	1.05	0.95
115-kV CMP	1.05	0.95
115-kV BHE	1.05	0.90

Table 2.2 - Steady State Voltage Criteria

The steady state analysis was performed with pre-contingency solution parameters that allowed adjustment of load tap-changing transformers (LTCs), static var devices (SVDs including switched capacitors) and phase angle regulators (PARs). Post-contingency solution parameters only allowed adjustment of LTCs and SVDs including switched capacitors.

2.3 Contingency List for Thermal and Voltage Analysis

Contingency Analysis was conducted with a list of normal design contingencies for the BHE Downeast area. Table 2.3 contains the contingencies that were simulated.

Name	Description
345kV Line Outages	
Sect 388	L/O Sect 388 Orrington - Maxcy's & Orrington T1 w/ Bucksport Over Current SPS
Sect 396	L/O Sect 396 Orrington - Chester - Keswick w/ MIS SPS
115kV Line Outages	
Line 60/205	L/O Line 60/205 Bucksport - Boggy Brook - Orrington
Line 205 North Open K205-1	L/O Line 205 Orrington - Betts Rd.
Line 205 South Open K205-2 & K205/249	L/O Line 205 Bucksport - Betts Rd.
Line 58/61 BHE	L/O Line 58/61 Tunk Lake - Hancock - Boggy Brook
Line 59/69 BHE	L/O Line 59/69 Tunk Lake - Harrington - Epping
Line 61	L/O Line 61 Boggy Brook - Hancock - Trenton
Line 65	L/O Line 65 Bucksport - Orrington
Line 66/67	L/O Line 66/67 Graham - WCS, Rebel Hill - Boggy Brook
Line 66-1/67 BHE	L/O Line 66-1/67 Graham - Epping, Rebel Hill - Boggy Brook
Line 66-2 BHE	L/O Line 66-2 Epping - WCS
Line 86	L/O Line 86 Bucksport - Belfast - Linconville - Meadow Rd - Highland
Line 203	L/O Line 203 Bucksport - Detroit
Line 246	L/O Line 246 Graham - Orrington
Line 248	L/O Line 248 Graham - Orrington
115kV Stuck Breakers	
Graham 246/64 SB	L/O Line 246/64 Graham - Orrington, Graham - Chester
Graham 248/66 SB	L/O Line 248/66 Graham - Orrington, Graham - WCS
Graham 248/66 SB BHE	L/O Line 248/66 Graham - Orrington, Graham - Epping
Loss of 345kV - 115kV Transformers	
Orrington T1	L/O Orrington T1 Transformer

Table 2.3 - Contingency List for Thermal and Voltage Analysis

2.3.1 Special Contingency Modeling Considerations

- The BHE designation in the table above defines contingencies that are only valid when the BHE Downeast Reliability Project is in-service.
- Contingencies involving Line 66/67 were modeled twice in order to represent the outage with and without the BHE Downeast Reliability Project in-service. Without the project in-service, contingencies involving loss of Line 66/67 take Graham to Washington County, the Harrington transformer, and Rebel Hill to Boggy Brook out of service. With the project in-service, contingencies involving loss of Line 66/67 take Graham to Epping and Rebel Hill to Boggy Brook out of service. Washington County and the Harrington transformer are no longer lost as part of these contingencies.
- Contingency 66-2 loses the section of Line 66 from the new Epping 115-kV switching station to Washington County.

3 Discussion of Steady State Analysis and Results

Steady state analyses were performed using the GE Power Systems, PSLF load flow software package. Contingencies were simulated with the Contingency Analysis (CA) tool. The CA software calculated a power flow solution for each contingency, reported subsequent thermal and voltage violations within the study area, and provided a relative comparison of thermal and voltage performance between related cases with the BHE Downeast Reliability Project in and out of service.

Contingency results for the summer peak, summer light and summer peak with NRI cases are contained in Appendices D and E. Appendix D includes the thermal results tables and Appendix E includes the voltage results tables.

Interpretation of entries in the thermal table:

- Results are shown for branches between busses with base voltages equal to or greater than 115-kV
- For each branch entry, at least one of the comparison cases represents a loading greater than 0.95pu
- Thermal loadings greater than 0.6pu are included for comparison
- Post-contingency entries represent a deviation of at least 0.005pu from the base loading
- Zero entries represent loading less than 0.6pu or deviation less than 0.005pu from the base loading
- Loadings exceeding 1.0pu are highlighted

Interpretation of entries in the voltage tables:

- Results are shown for busses with base voltages equal to or greater than 115-kV
- For each bus entry, at least one of the comparison cases represents a violation of criteria
- Voltages less than 0.97pu are included for comparison
- Post-contingency entries represent a deviation of at least 0.005pu from the base case voltage
- Zero entries represent voltages less than 1.05pu, greater than 0.95pu or with deviation less than 0.005pu from the base case voltage
- Voltages below 0.95pu are highlighted
- Voltages above 1.05pu are highlighted

The results of the thermal and voltage analyses are described in the following subsections.

3.1 Reliability Improvement for the Downeast Region Transmission System

3.1.1 Baseline System Performance

The existing BHE Downeast system supplies radial transmission service to the load east of Rebel Hill.

Base Case – All Lines In

Steady state analyses showed no violations of reliability criteria with the baseline configuration and all lines in-service.

115-kV Graham – Washington County & Rebel Hill – Boggy Brook (Line 66/67) Outage

With the baseline system, loss of Line 66/67 cuts off supply to the load east of Rebel Hill.

115-kV Graham 248/66 SB (Line 248/66) Outage

With the baseline system, loss of Line 66/67 as part of the stuck breaker contingency cuts off supply to the load east of Rebel Hill.

3.1.2 BHE Downeast Reliability Project System Performance

The BHE Downeast Reliability Project demonstrated improved system reliability for the load east of Rebel Hill by providing loop flows to Deblois, Epping, Harrington, and Washington County Substations.

Base Case – All Lines In

Steady state analyses showed no violations of reliability criteria with the BHE Downeast Reliability Project in-service.

115-kV Graham – Epping & Rebel Hill – Boggy Brook (Line 66-1/67 BHE) Outage

With the BHE Downeast Reliability Project in-service, the new 115-kV Epping switching station alters the Line 66/67 contingency. Only the Graham to Epping section of Line 66 is lost as part of this outage. The new 115-kV line provides radial transmission service to Harrington and Washington County Substations.

115-kV Epping – Washington County (Line 66-2 BHE) Outage

With the BHE Downeast Reliability Project in-service, the new 115-kV Epping switching station creates the Line 66-2 (Epping – Washington County) contingency. This outage removes the 115-kV feed to Washington County; however, Harrington Substation provides support across the underlying 34.5-kV system to serve the Washington County load. The new 115-kV line provided loop transmission to Harrington and improved reliability service to load in the Washington County Area.

115-kV Graham 248/66 SB (Line 248/66 BHE) Outage

With the BHE Downeast Reliability Project in-service, the new 115-kV Epping switching station alters the Graham 248/66 stuck breaker contingency. Only the Graham to Epping section of Line 66 is lost as part of this outage. The new 115-kV line provides radial transmission service to Harrington and Washington County Substations.

3.2 Local Area Issues – No Adverse Impact

115-kV Graham 246/64 SB (Line 246/64) Outage

As a result of this stuck breaker contingency, Chester's underlying system is fed radial from the Graham 46-kV Substation. Under certain load and generation levels there is a potential for voltage collapse in this area. This is a known local area problem that is not affected by the BHE Downeast Reliability Project.

4 Discussion of Short Circuit Analysis and Results

Three-phase and single-phase fault currents were calculated by BHE for relevant substations in the BHE Downeast region. Fault currents were calculated with and without the NRI Project in-service. The results of these calculations, summarized in Appendix F indicate no over-duty conditions on the equipment interrupting capabilities as a result of the project.

5 Conclusions

This study evaluated the impact that the BHE Downeast Reliability Project has on the reliability and operability of the interconnected bulk power transmission system. Steady state thermal and voltage analyses examined 2009 summer peak (29,090 MW) and 2009 summer light (14,490 MW) NEPOOL load levels. Two generation dispatch patterns were represented for each load level to stress system conditions. The 2009 summer peak NEPOOL load level was also analyzed with the Northeast Reliability Interconnection Project (NRI) in-service as a sensitivity.

The results of the steady state analysis show improved transmission service reliability for BHE's Downeast region.

- The BHE Downeast Reliability Project improved system reliability for the Downeast Area by providing loop feed to Deblois, Epping, Harrington, and Washington County Substations.
- Building new 115-kV transmission between Hancock and Harrington Substation and upgrading the 115-kV Epping Substation eliminate the isolation of 115-kV substations for Line 66 contingencies.

The BHE Downeast Reliability Project demonstrated acceptable system performance for the conditions and assumptions included in this analysis. The BHE Downeast Reliability Project showed no adverse impact on the reliability or operability of the interconnected bulk power transmission system and did not cause fault duties to exceed equipment interrupting capabilities/ratings.

APPENDIX A – Interface and Dispatch Summaries

Appendix A-1: 2009 Summer Peak Load

Appendix A-2: 2009 Summer Light Load

Appendix A-3: 2009 Summer Peak Load, NRI in-Service

**Interface and Dispatch Summary
2009 Summer Peak Base Cases**

	<u>GENERATOR</u>	-----Summer PK 2009 CASES-----			
		MIS Off, GLHA On, BHE OOS	MIS Off, GLHA On, BHE IS	MIS On, GLHA Off, BHE OOS	MIS On, GLHA Off, BHE IS
SYSTEM LOAD & LOSSES	New England	29090	29090	29090	29090
MAJOR INTERFACES	New Brunswick-New England	700	700	700	700
	Orrington-South	669	670	1000	1000
	Surowiec-South	476	477	812	812
	SUROWIEC-SOUTH_Y138	606	607	918	918
	Northern Maine Import	-44	-44	-66	-66
	Northern Maine Import Y138	-174	-174	-172	-172
	North Western Maine Export	646	646	646	646
	Maine-New Hampshire	705	706	1035	1036
	ME_NH_K1214	879	880	1186	1186
	Northern NE-Scobie + 394	2201	2201	2486	2486
	Seabrook-South	1583	1583	1644	1644
	Sandy Pond-South	1889	1890	2025	2025
	North-South	2060	2061	2359	2364
	New England East-West	-490	-489	-489	-489
New York-New England	7	7	11	11	
MAINE	BELLC	191	191	110	110
	No. Hydro (Harris, Wyman, Williams)	183	183	183	183
	Nugs (SEA, Gorbell, AEI)	87	87	87	87
	RPA #1-2	266	266	266	266
	AEC #1-3	149	149	149	149
	Redington	30	30	30	30
	WEC #1-3	531	531	531	531
	Yarmouth #1-3	225	225	225	225
	Yarmouth #4	0	0	0	0
BHE	MIS	0	0	551	551
	Milford	5	5	5	5
	W. Enfield Hydro	8	8	8	8
	Medway Hydro	3	3	3	3
	Medway Diesel	0	0	0	0
	Veazie Hydro	6	6	6	6
	Howland	1	1	1	1
	UP5 Gen	0	0	0	0
	Sebec Hydro	0	0	0	0
	Ellsworth Station	1	1	1	1
	Youngs Corner Diesel	0	0	0	0
	Eastport Diesel	0	0	0	0
	UP6 Gen	0	0	0	0
	Perc Gen	17	17	17	17
	PPA Gen	0	0	0	0
	GLHA	126	126	0	0
BHE Total Generation	167	167	592	592	

Interface and Dispatch Summary 2009 Summer Light Base Cases

	<u>GENERATOR</u>	-----Summer LT 2009 CASES-----			
		MIS Off, BKSPRT On, BHE OOS	MIS Off, BKSPRT On, BHE IS	MIS On, BKSPRT Off, BHE OOS	MIS On, BKSPRT Off, BHE IS
SYSTEM LOAD & LOSSES	New England	14490	14490	14490	14490
MAJOR INTERFACES	New Brunswick-New England	700	700	700	700
	Orrington-South	843	843	1184	1184
	Surowiec-South	737	737	1059	1059
	SUROWIEC-SOUTH_Y138	886	886	1204	1204
	Maine-New Hampshire	521	521	837	837
	ME_NH_K1214	692	692	1004	1004
	Northern NE-Scobie + 394	1921	1921	2199	2199
	Seabrook-South	1315	1315	1375	1375
	Sandy Pond-South	1841	1841	1972	1972
	North-South	2715	2715	3017	3017
	New England East-West	1678	1679	1683	1683
New York-New England	9	9	9	9	
MAINE	BELLC	191	191	0	0
	No. Hydro (Harris, Wyman, Williams)	25	25	25	25
	Nugs (SEA, Gorbell, AEI)	87	87	87	87
	RPA #1-2	266	266	266	266
	AEC #1-3	50	50	50	50
	Redington	30	30	30	30
	WEC #1-3	0	0	0	0
	Yarmouth #1-3	0	0	0	0
	Yarmouth #4	0	0	0	0
BHE	MIS	0	0	549	549
	Milford	0	0	0	0
	W. Enfield Hydro	0	0	0	0
	Medway Hydro	0	0	0	0
	Medway Diesel	0	0	0	0
	Veazie Hydro	0	0	0	0
	Howland	0	0	0	0
	UP5 Gen	0	0	0	0
	Sebec Hydro	1	1	1	1
	Ellsworth Station	9	9	9	9
	Youngs Corner Diesel	0	0	0	0
	Eastport Diesel	4	4	4	4
	UP6 Gen	0	0	0	0
	Perc Gen	25	25	25	25
	PPA Gen	0	0	0	0
	GLHA	115	115	115	115
	BHE Total Generation	154	154	703	703

Interface and Dispatch Summary
2009 Summer Peak Base Cases
NRI In Service

	<u>GENERATOR</u>	Summer PK 2009 CASES	
		MIS On, GLHA Off, BHE OOS	MIS On, GLHA Off, BHE IS
SYSTEM LOAD & LOSSES	New England	29090	29090
MAJOR INTERFACES	New Brunswick-New England Orrington-South Surowiec-South SUROWIEC-SOUTH_Y138 Northern Maine Import Northern Maine Import Y138 North Western Maine Export Maine-New Hampshire ME_NH_K1214 Northern NE-Scobie + 394 Seabrook-South Sandy Pond-South North-South New England East-West New York-New England	1000 1195 989 1101 -62 -174 646 1209 1365 2635 1675 2098 2535 -486 11	1000 1196 989 1101 -62 -174 646 1209 1366 2635 1675 2098 2535 -486 10
MAINE	BELLC No. Hydro (Harris, Wyman, Williams) Nugs (SEA, Gorbell, AEI) RPA #1-2 AEC #1-3 Redington WEC #1-3 Yarmouth #1-3 Yarmouth #4	0 183 87 266 149 30 531 225 0	0 183 87 266 149 30 531 225 0
BHE	MIS Milford W. Enfield Hydro Medway Hydro Medway Diesel Veazie Hydro Howland UP5 Gen Sebec Hydro Ellsworth Station Youngs Corner Diesel Eastport Diesel UP6 Gen Perc Gen PPA Gen GLHA BHE Total Generation	551 5 8 3 0 6 1 0 0 1 0 0 0 0 17 0 0 592	551 5 8 3 0 6 1 0 0 1 0 0 0 17 0 0 592

APPENDIX B – Base Case Draw Files

Appendix B-1: 2009 Summer Peak Load

Appendix B-2: 2009 Summer Light Load

Appendix B-3: 2009 Summer Peak Load, NRI in-Service

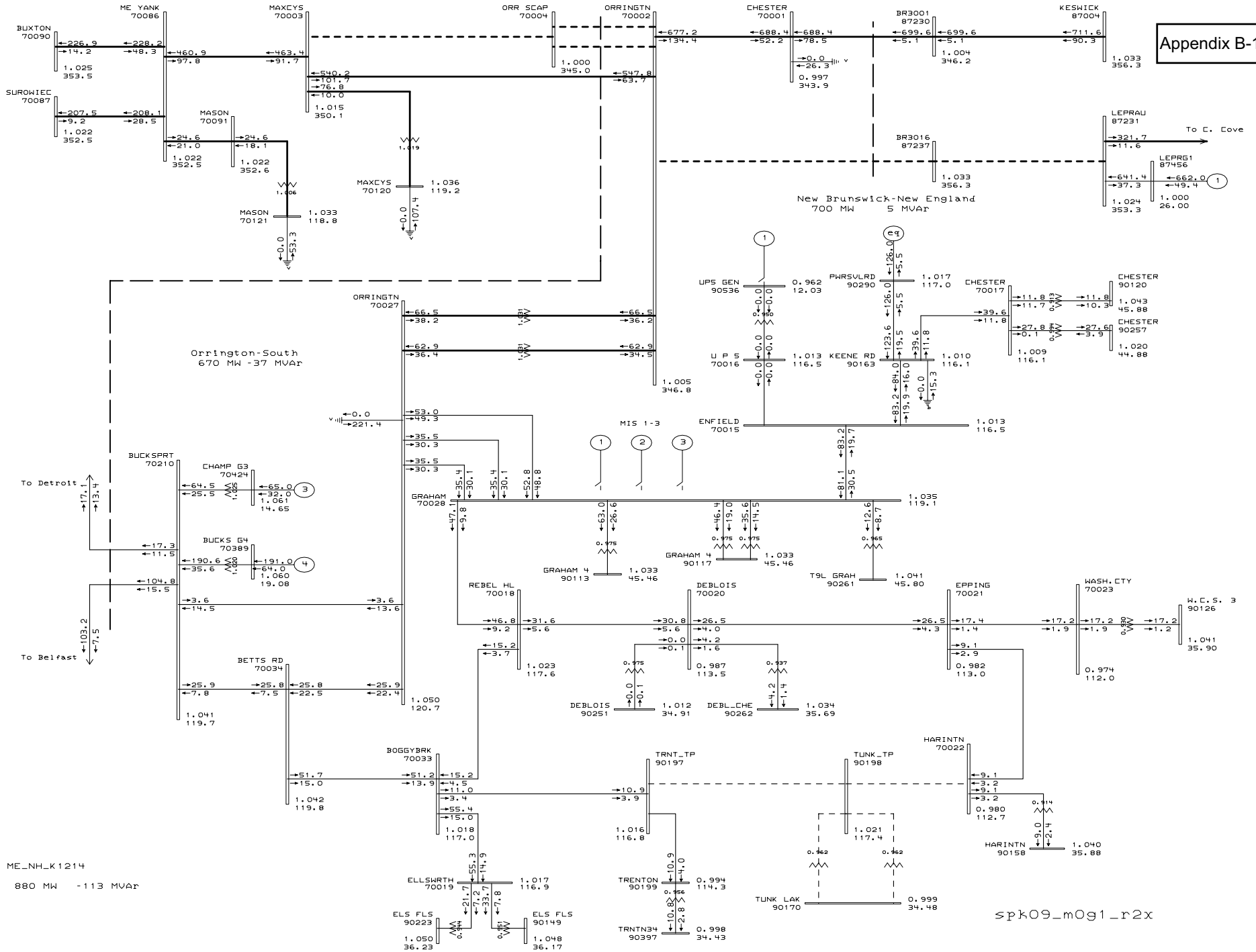

ME_NH_LK1214
880 MW -113 MVar

spk09_m0g1_r2x



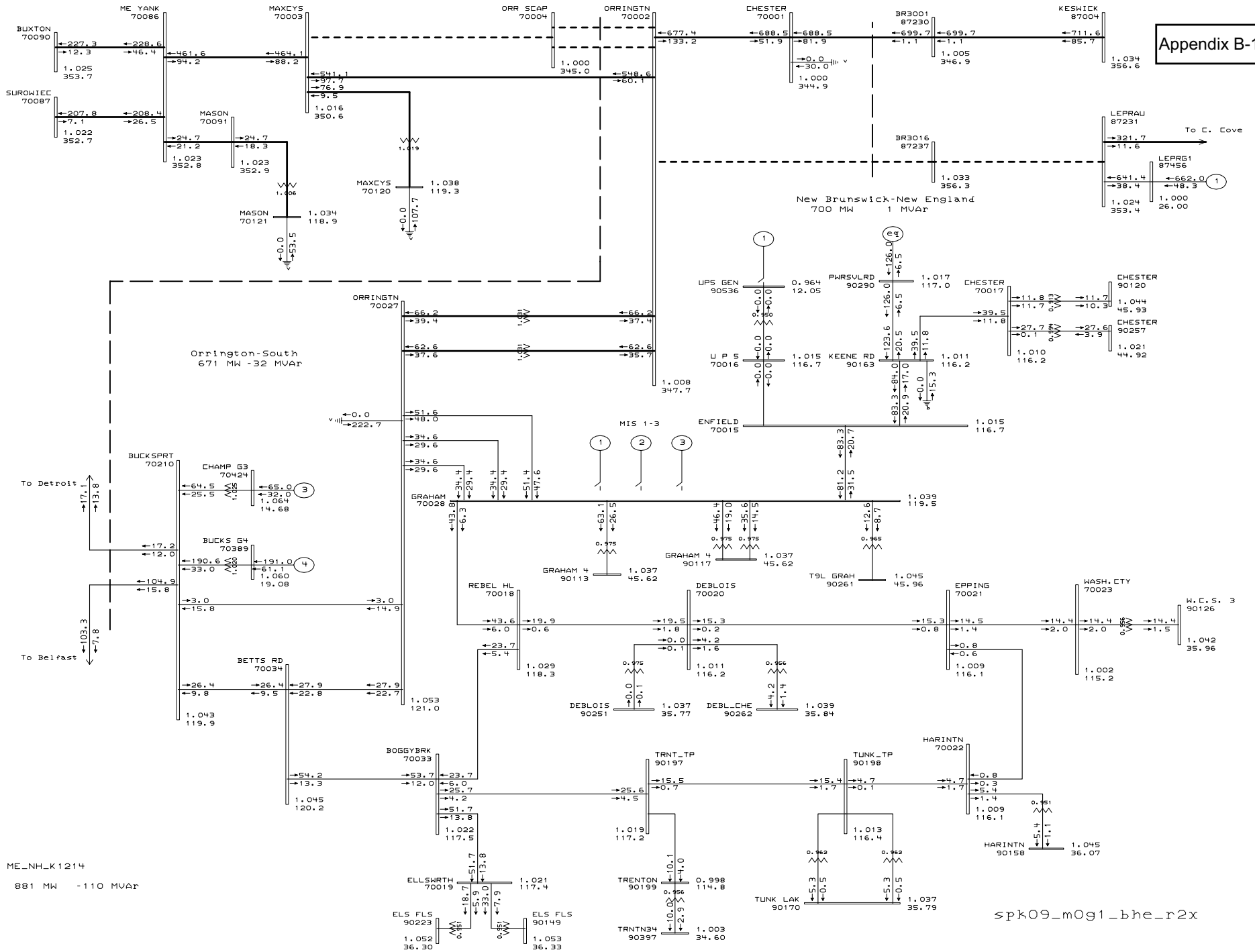

ME_NH_LK1214
881 MW -110 MVar

spk09_m0g1_bhe_r2x



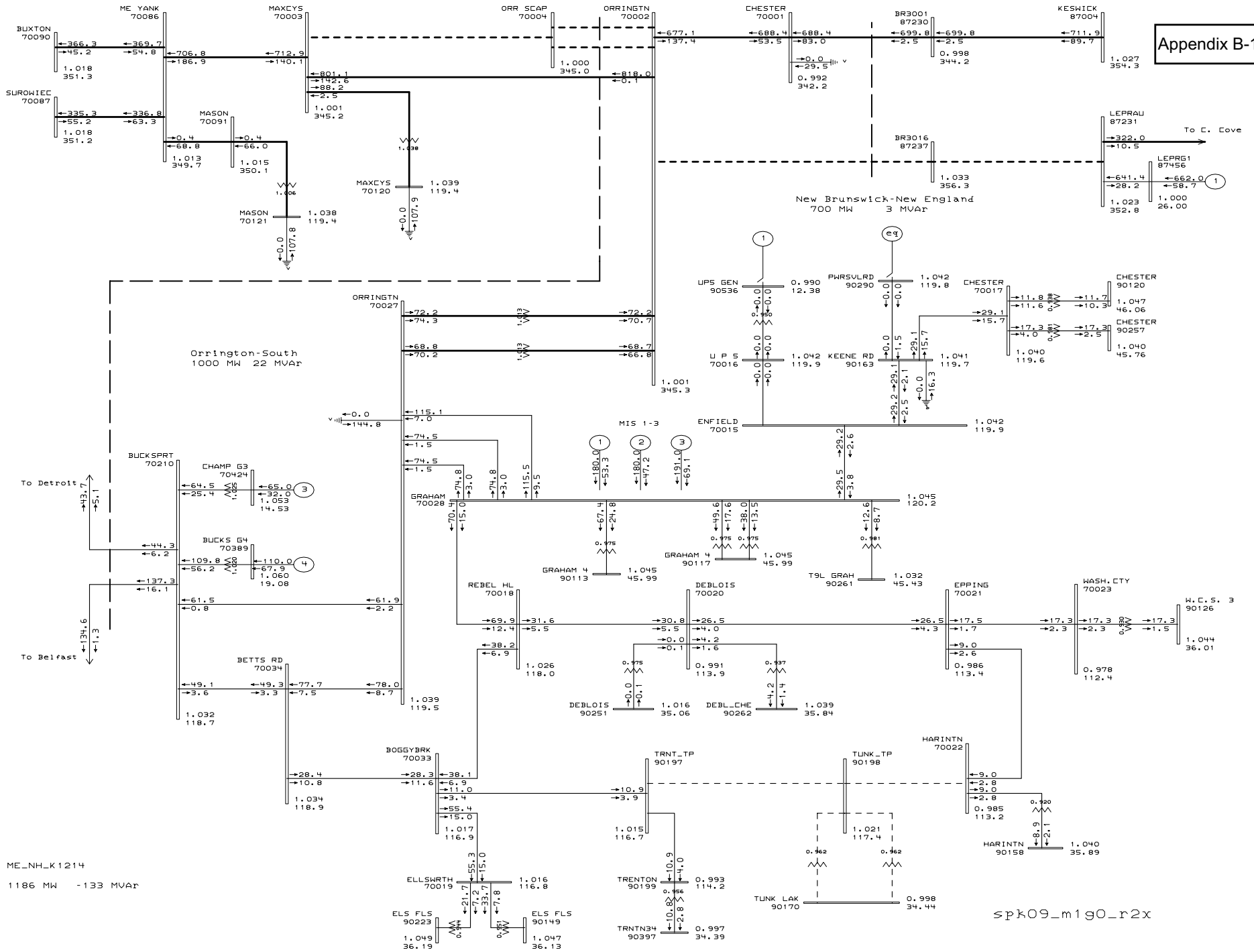

ME_NH_LK 1214
1186 MW -133 MVar

spk09_m1g0_r2x



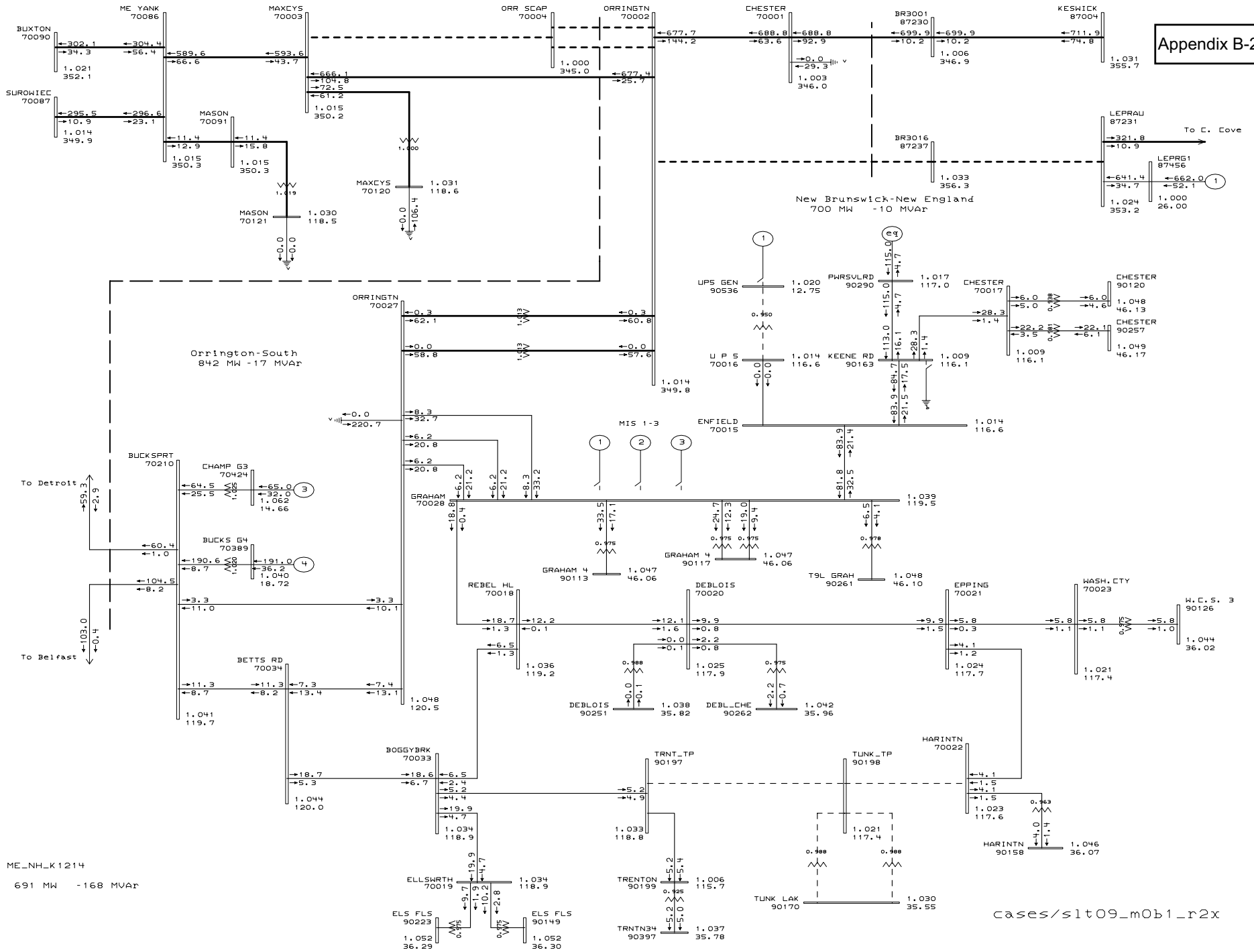

ME_NH_LK1214
691 MW -168 MVar

cases/slt09_m0b1_r2x



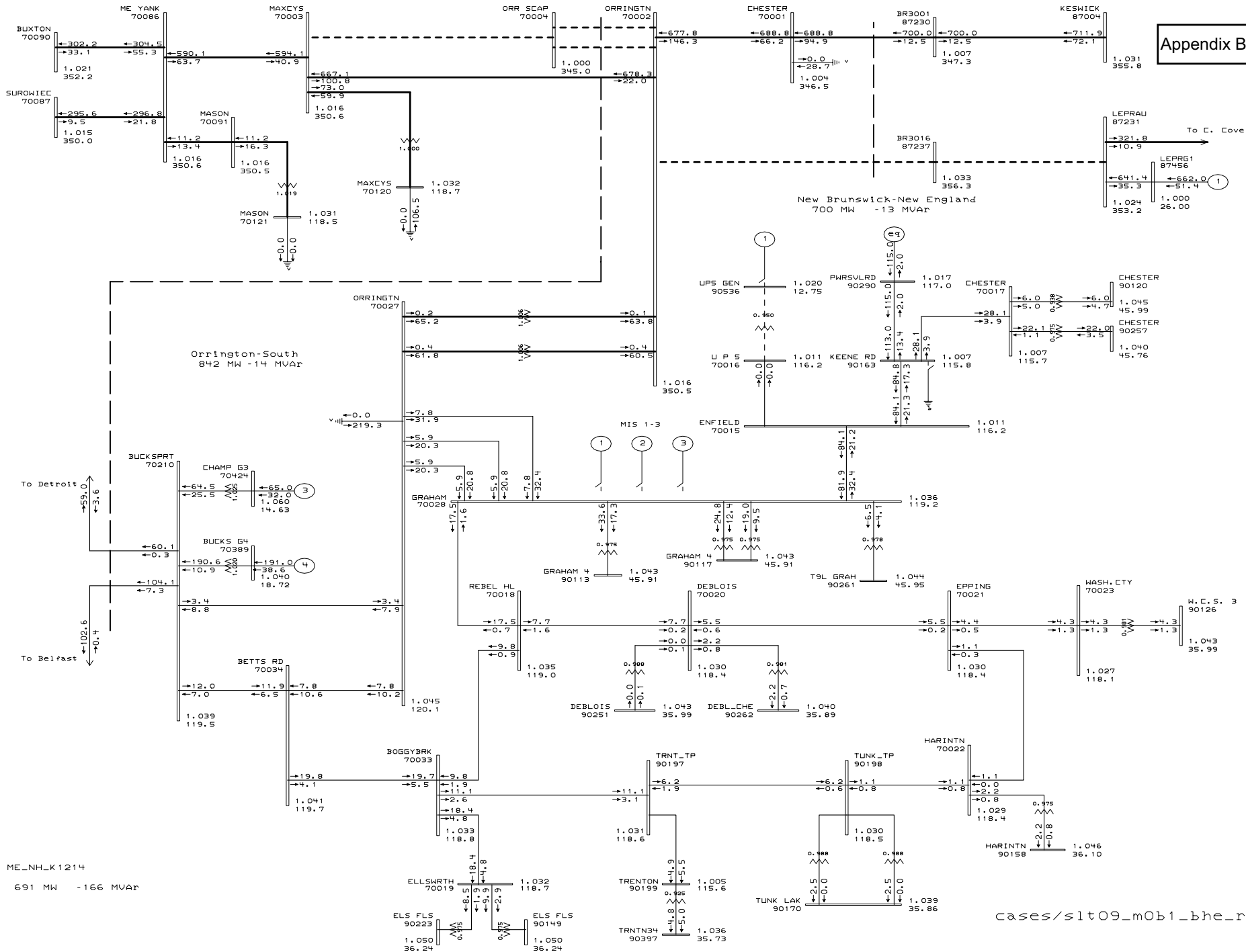

cases/slt09_m0b1_bhe_r2x

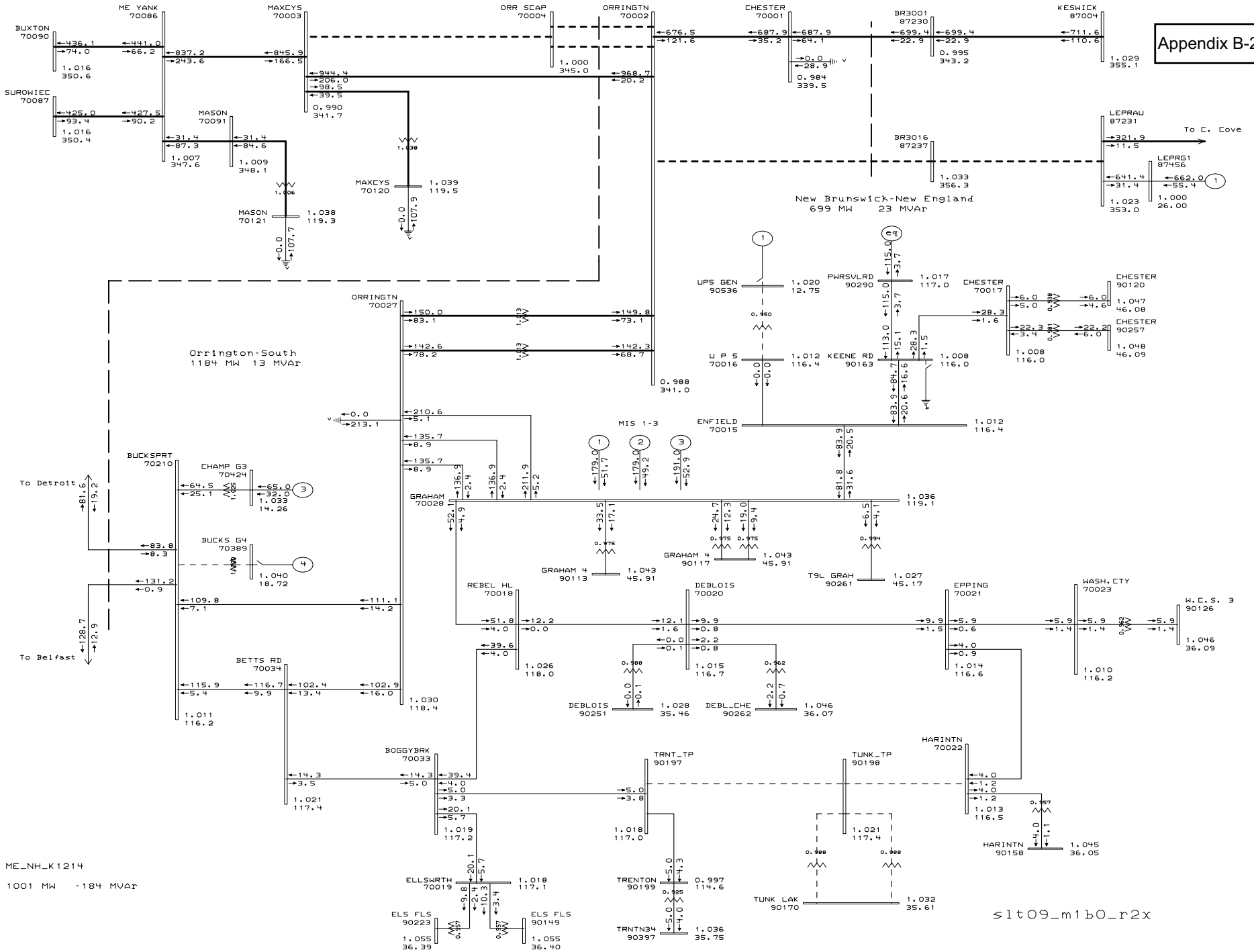

ME_NH_LK1214
1001 MW -184 MVar

s1t09_m1b0_r2x



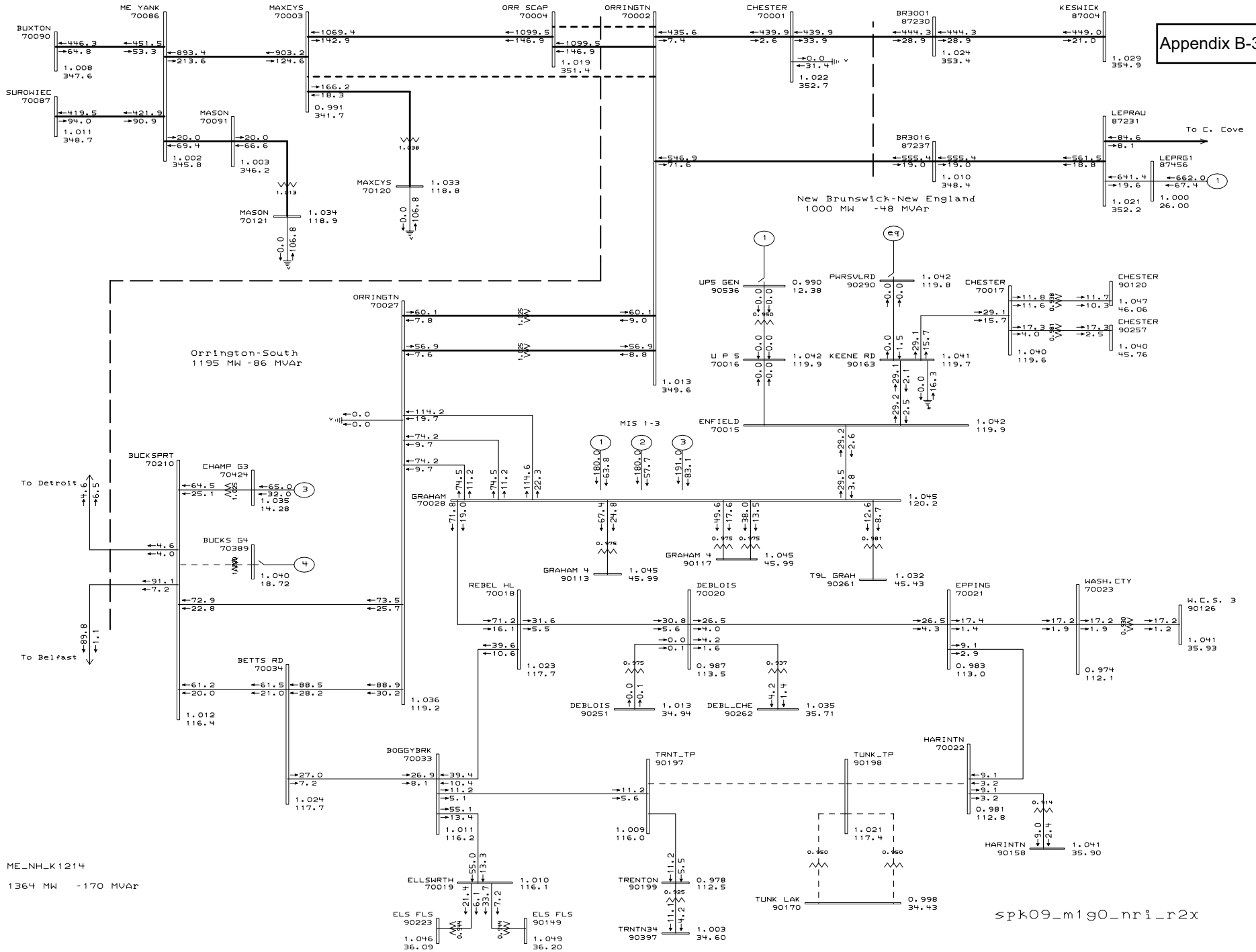

ME_NH_LK1214
1364 MW -170 MVar

spk09_m1g0_nri_r2x



APPENDIX C – Contingency Descriptions

BHE Downeast Transmission Reliability Improvement Assessment

Appendix C - Contingency Analysis Description

Name	Description
345kV Line Outages	
Sect 388	L/O Sect 388 Orrington - Maxcy's & Orrington T1 w/ Bucksport Over Current SPS
Sect 396	L/O Sect 396 Orrington - Chester - Keswick w/ MIS SPS
115kV Line Outages	
Line 60/205	L/O Line 60/205 Bucksport - Boggy Brook - Orrington
Line 205 North Open K205-1	L/O Line 205 Orrington - Betts Rd.
Line 205 South Open K205-2 & K205/249	L/O Line 205 Bucksport - Betts Rd.
Line 58/61 BHE	L/O Line 58/61 Tunk Lake - Hancock - Boggy Brook
Line 59/69 BHE	L/O Line 59/69 Tunk Lake - Harrington - Epping
Line 61	L/O Line 61 Boggy Brook - Hancock - Trenton
Line 65	L/O Line 65 Bucksport - Orrington
Line 66/67	L/O Line 66/67 Graham - WCS, Rebel Hill - Boggy Brook
Line 66-1/67 BHE	L/O Line 66-1/67 Graham - Epping, Rebel Hill - Boggy Brook
Line 66-2 BHE	L/O Line 66-2 Epping - WCS
Line 86	L/O Line 86 Bucksport - Belfast - Linconville - Meadow Rd - Highland
Line 203	L/O Line 203 Bucksport - Detroit
Line 246	L/O Line 246 Graham - Orrington
Line 248	L/O Line 248 Graham - Orrington
115kV Stuck Breakers	
Graham 246/64 SB	L/O Line 246/64 Graham - Orrington, Graham - Chester
Graham 248/66 SB	L/O Line 248/66 Graham - Orrington, Graham - WCS
Graham 248/66 SB BHE	L/O Line 248/66 Graham - Orrington, Graham - Epping
Loss of 345kV - 115kV Transformers	
Orrington T1	L/O Orrington T1 Transformer

APPENDIX D – Contingency Analysis Thermal Results

Appendix D-1: 2009 Summer Peak Load

Appendix D-2: 2009 Summer Light Load

* No thermal violations occurred for 2009 Summer Peak Load, NRI in-service

Interpretation of entries in the thermal table:

- Results are shown for branches between busses with base voltages equal to or greater than 115-kV
- For each branch entry, at least one of the comparison cases represents a loading greater than 0.95pu
- Thermal loadings greater than 0.6pu are included for comparison
- Post-contingency entries represent a deviation of at least 0.005pu from the base loading
- Zero entries represent loading less than 0.6pu or deviation less than 0.005pu from the base loading
- Loadings exceeding 1.0pu are highlighted

Appendix D-1
BHE Downeast Reliability Project
Contingency Analysis Thermal Results \geq 115-kV
Summer 2009 Peak Load

Contingency Name	-----From-----				-----To-----				Ckt ID	Type	Rate	M0G1	M0G1 BHE	M1G0	M1G0 BHE	Contingency Description
	Bus	Name	KV	A/Z	Bus	Name	KV	A/Z								
base	70015	ENFIELD	115	4	70028	GRAHAM	115	4	1	line	442	0.959	0.961	0	0	Base system (n-0)
base	70015	ENFIELD	115	4	90163	KEENE RD	115	6	1	line	442	0.962	0.964	0	0	Base system (n-0)
base	70109	BELFAST	115	8	70210	BUCKSPRT	115	1	1	line	679	0.753	0.752	0.991	0.99	Base system (n-0)
base	70180	LOVELL	115	8	72761	SACO VLY	115	28	1	line	929	0.95	0.95	0.804	0.806	Base system (n-0)
Graham 66_2_BHE	70015	ENFIELD	115	4	70028	GRAHAM	115	4	1	line	442	N/A	0.96	N/A	0	L/O Line 66-2 Epping - WCS BHE
Graham 66_2_BHE	70015	ENFIELD	115	4	90163	KEENE RD	115	6	1	line	442	N/A	0.962	N/A	0	L/O Line 66-2 Epping - WCS BHE
Line 246	70015	ENFIELD	115	4	90163	KEENE RD	115	6	1	line	442	0	0.958	0	0	L/O Line 246 Graham - Orrington
Sect 388	70015	ENFIELD	115	4	70028	GRAHAM	115	4	1	line	442	0.958	0.956	0	0	L/O Sect 388 Orrington - Maxcy's & Orrington T2
Sect 388	70015	ENFIELD	115	4	90163	KEENE RD	115	6	1	line	442	0.96	0.958	0	0	L/O Sect 388 Orrington - Maxcy's & Orrington T2

Appendix D-2
BHE Downeast Reliability Project
Contingency Analysis Thermal Results \geq 115-kV
Summer 2009 Light Load

Contingency Name	From				To				Ckt ID	Type	Rate	M0B1	M0B1 BHE	M1B0	M1B0 BHE	Contingency Description
	Bus	Name	KV	A/Z	Bus	Name	KV	A/Z								
base	70015	ENFIELD	115	4	70028	GRAHAM	115	4	1	line	442	0.971	0.975	0.97	0.97	Base system (n-0)
base	70015	ENFIELD	115	4	90163	KEENE RD	115	6	1	line	442	0.974	0.977	0.972	0.972	Base system (n-0)
base	70109	BELFAST	115	8	70210	BUCKSPRT	115	1	1	line	679	0.744	0.742	0.96	0.963	Base system (n-0)
Line 203	70015	ENFIELD	115	4	70028	GRAHAM	115	4	1	line	442	0	0.97	0	0	L/O Line 203 Bucksport - Detroit
Line 203	70015	ENFIELD	115	4	90163	KEENE RD	115	6	1	line	442	0	0.972	0	0	L/O Line 203 Bucksport - Detroit
Line 246	70027	ORRINGTN	115	4	70028	GRAHAM	115	4	2	line	1175	0	0	0.974	0.973	L/O Line 246 Graham - Orrington
Line 246	70027	ORRINGTN	115	4	70028	GRAHAM	115	4	1	line	1175	0	0	0.974	0.973	L/O Line 246 Graham - Orrington
Line 86	70015	ENFIELD	115	4	70028	GRAHAM	115	4	1	line	442	0	0.969	0	0	L/O Line 86 Bucksp-Belfast-Lincnvil-Meadow Rd-Highland
Line 86	70015	ENFIELD	115	4	90163	KEENE RD	115	6	1	line	442	0	0.971	0	0	L/O Line 86 Bucksp-Belfast-Lincnvil-Meadow Rd-Highland
Orrington T1	70015	ENFIELD	115	4	70028	GRAHAM	115	4	1	line	442	0	0	0.975	0.976	L/O Orrington T1
Orrington T1	70015	ENFIELD	115	4	90163	KEENE RD	115	6	1	line	442	0	0	0.978	0.979	L/O Orrington T1

APPENDIX E – Contingency Analysis Voltage Results

Appendix E-1: 2009 Summer Peak Load

Appendix E-2: 2009 Summer Light Load

Appendix E-3: 2009 Summer Peak Load, NRI in-Service

Interpretation of entries in the voltage tables:

- Results are shown for busses with base voltages equal to or greater than 115-kV
- For each bus entry, at least one of the comparison cases represents a violation of criteria
- Voltages less than 0.97pu are included for comparison
- Post-contingency entries represent a deviation of at least 0.005pu from the base case voltage
- Zero entries represent voltages less than 1.05pu, greater than 0.95pu or with deviation less than 0.005pu from the base case voltage
- Voltages below 0.95pu are highlighted
- Voltages above 1.05pu are highlighted

Appendix E-1

BHE Downeast Reliability Project

Contingency Analysis Voltage Results ≥ 115 -kV

Summer 2009 Peak Load

Base Case Limits
1.0 And 1.05 pu

Cont. Case Limits
0.95 And 1.05 pu

Contingency Name	Bus	Name	KV	A/Z	M0G1	M0G1 BHE	M1G0	M1G0 BHE	Contingency Description
base	70001	CHESTER	345	1	0.997	1	0.992	0.992	Base system (n-0)
base	90199	TRENTON	115	2	0.994	0.998	0.993	0.995	Base system (n-0)
base	70014	PERC TAP	115	4	1.051	1.054	0	0	Base system (n-0)
base	70020	DEBLOIS	115	4	0.987	0	0.991	0	Base system (n-0)
base	70021	EPPING	115	4	0.982	0	0.986	0	Base system (n-0)
base	70022	HARINTN	115	4	0.98	0	0.985	0	Base system (n-0)
base	70023	WASH.CTY	115	4	0.974	0	0.978	0	Base system (n-0)
base	70027	ORRINGTON	115	4	0	1.053	0	0	Base system (n-0)
base	70035	L C P	115	5	1.051	1.054	0	0	Base system (n-0)
base	90246	PERC 115	115	5	1.051	1.054	0	0	Base system (n-0)
base	70126	BRNCHBRK	115	8	0.999	0.999	0.995	0.995	Base system (n-0)
base	70137	MAGR163	115	8	0	0	0.999	0.999	Base system (n-0)
base	70157	GUILF GN	115	8	0.997	0.998	0.993	0.994	Base system (n-0)
base	70180	LOVELL	115	8	0.994	0.995	0	0	Base system (n-0)
Graham 248_66BH	70021	EPPING	115	4	N/A	0	N/A	0.947	L/O Line 248/66 Graham-Orrington & Eppng BHE
Graham 248_66BH	70022	HARINTN	115	4	N/A	0	N/A	0.949	L/O Line 248/66 Graham-Orrington & Eppng BHE
Graham 248_66BH	70023	WASH.CTY	115	4	N/A	0	N/A	0.94	L/O Line 248/66 Graham-Orrington & Eppng BHE
Graham 66_1_BHE	70021	EPPING	115	4	N/A	0	N/A	0.949	L/O Line 66-1 Graham - Epping BHE
Graham 66_1_BHE	70023	WASH.CTY	115	4	N/A	0	N/A	0.941	L/O Line 66-1 Graham - Epping BHE
Line 60_205	70022	HARINTN	115	4	0.949	0	0	0	L/O Line 60/205 Bucksport - Boggy Brook - Orrington
Line 60_205	70023	WASH.CTY	115	4	0.942	0	0	0	L/O Line 60/205 Bucksport - Boggy Brook - Orrington

Appendix E-2

BHE Downeast Reliability Project

Contingency Analysis Voltage Results ≥ 115 -kV

Summer 2009 Light Load

Base Case Limits
1.0 And 1.05 pu

Cont. Case Limits
0.95 And 1.05 pu

Contingency Name	Bus	Name	KV	A/Z	MOB1	MOB1 BHE	M1B0	M1B0 BHE	Contingency Description
base	70001	CHESTER	345	1	0	0	0.984	0.986	Base system (n-0)
base	70002	ORRINGTON	345	1	0	0	0.988	0.987	Base system (n-0)
base	70003	MAXCYS	345	1	0	0	0.99	0.984	Base system (n-0)
base	70086	ME YANK	345	8	0	0	0	0.999	Base system (n-0)
base	90199	TRENTON	115	2	0	0	0.997	0.994	Base system (n-0)
base	70109	BELFAST	115	8	0	0	0.996	0.991	Base system (n-0)
base	70149	MEADOWRD	115	8	0	0	0	1	Base system (n-0)
base	70150	S83C TAP	115	8	0	0	0	0.996	Base system (n-0)
base	70157	GUILF GN	115	8	0	0	0	0.998	Base system (n-0)
base	70173	SDW SOMS	115	8	0.998	0.998	1	0.991	Base system (n-0)
base	70178	LINCNVIL	115	8	0	0	0	0.995	Base system (n-0)
base	70180	LOVELL	115	8	0.965	0.965	0.978	0.972	Base system (n-0)
base	90079	S 214 TP	115	8	1	1	0	0	Base system (n-0)
base	90530	SV PAR	115	8	0.967	0.967	0.98	0.974	Base system (n-0)
Graham 246_64 SB	70028	GRAHAM	115	4	0	0	0	1.05	L/O Line 246/64 Graham - Orrington & Chester
Graham 246_64 SB	70030	MIS G1	115	4	0	0	0	1.051	L/O Line 246/64 Graham - Orrington & Chester
Graham 246_64 SB	70031	MIS G2	115	4	0	0	0	1.051	L/O Line 246/64 Graham - Orrington & Chester
Graham 246_64 SB	70032	MIS G3	115	4	0	0	0	1.051	L/O Line 246/64 Graham - Orrington & Chester
Graham 246_64 SB	70169	SEA	115	8	0	0	0	1.052	L/O Line 246/64 Graham - Orrington & Chester
Line 203	70169	SEA	115	8	0	0	0	1.051	L/O Line 203 Bucksport - Detroit
Sect 388	70003	MAXCYS	345	1	0	0	1.05	0	L/O Sect 388 Orrington - Maxcy's & Orrington T2
Sect 388	70086	ME YANK	345	8	0	0	1.054	0	L/O Sect 388 Orrington - Maxcy's & Orrington T2
Sect 388	70087	SUROWIEC	345	8	0	0	1.053	0	L/O Sect 388 Orrington - Maxcy's & Orrington T2
Sect 388	70088	WYMAN	345	8	0	0	1.055	1.051	L/O Sect 388 Orrington - Maxcy's & Orrington T2
Sect 388	70089	S.GORHAM	345	8	0	0	1.053	0	L/O Sect 388 Orrington - Maxcy's & Orrington T2
Sect 388	70090	BUXTON	345	8	0	0	1.055	1.051	L/O Sect 388 Orrington - Maxcy's & Orrington T2
Sect 388	70091	MASON	345	8	0	0	1.054	0	L/O Sect 388 Orrington - Maxcy's & Orrington T2
Sect 388	70101	RUMFRDGN	115	8	0	0	0	1.051	L/O Sect 388 Orrington - Maxcy's & Orrington T2
Sect 388	70169	SEA	115	8	0	0	0	1.052	L/O Sect 388 Orrington - Maxcy's & Orrington T2
Sect 388	70182	RUMFD IP	115	8	1.05	0	0	1.052	L/O Sect 388 Orrington - Maxcy's & Orrington T2
Sect 388	70184	AEC 115	115	8	0	0	0	1.05	L/O Sect 388 Orrington - Maxcy's & Orrington T2
Sect 388	70186	RPA 115	115	8	1.05	0	0	1.052	L/O Sect 388 Orrington - Maxcy's & Orrington T2
Sect 396	70182	RUMFD IP	115	8	0	0	0	1.05	L/O Sect 396 Orrington - Chester - Keswick w MIS SPS

Appendix E-3

BHE Downeast Reliability Project

Contingency Analysis Voltage Results ≥ 115 -kV

Summer 2009 Peak Load; NRI IS

Base Case Limits
1.0 And 1.05 pu

Cont. Case Limits
0.95 And 1.05 pu

Contingency Name	Bus	Name	KV	A/Z	M1G0	M1G0 BHE	Contingency Description
base	70003	MAXCYS	345	1	0.991	0.991	Base system (n-0)
base	90199	TRENTON	115	2	0.978	0.98	Base system (n-0)
base	70020	DEBLOIS	115	4	0.987	0	Base system (n-0)
base	70021	EPPING	115	4	0.983	0	Base system (n-0)
base	70022	HARINTN	115	4	0.981	0	Base system (n-0)
base	70023	WASH.CTY	115	4	0.974	0.996	Base system (n-0)
base	70109	BELFAST	115	8	0.995	0.995	Base system (n-0)
base	70145	S206A TP	115	8	0.998	0.998	Base system (n-0)
base	70146	PARK ST.	115	8	0.997	0.997	Base system (n-0)
base	70149	MEADOWRD	115	8	0.997	0.997	Base system (n-0)
base	70157	GUILF GN	115	8	0.985	0.985	Base system (n-0)
base	70166	S86B TAP	115	8	0.999	0.999	Base system (n-0)
base	70178	LINCNVIL	115	8	0.997	0.998	Base system (n-0)
<hr/>							
Graham 248_66BH	90199	TRENTON	115	2	N/A	0.943	L/O Line 248/66 Graham-Orrington & Eppng BHE
Graham 248_66BH	70021	EPPING	115	4	N/A	0.929	L/O Line 248/66 Graham-Orrington & Eppng BHE
Graham 248_66BH	70022	HARINTN	115	4	N/A	0.931	L/O Line 248/66 Graham-Orrington & Eppng BHE
Graham 248_66BH	70023	WASH.CTY	115	4	N/A	0.921	L/O Line 248/66 Graham-Orrington & Eppng BHE
Graham 248_66BH	90198	TUNK_TP	115	4	N/A	0.945	L/O Line 248/66 Graham-Orrington & Eppng BHE
<hr/>							
Graham 66_1_BHE	90199	TRENTON	115	2	N/A	0.945	L/O Line 66-1 Graham - Epping BHE
Graham 66_1_BHE	70021	EPPING	115	4	N/A	0.932	L/O Line 66-1 Graham - Epping BHE
Graham 66_1_BHE	70022	HARINTN	115	4	N/A	0.935	L/O Line 66-1 Graham - Epping BHE
Graham 66_1_BHE	70023	WASH.CTY	115	4	N/A	0.924	L/O Line 66-1 Graham - Epping BHE
Graham 66_1_BHE	90198	TUNK_TP	115	4	N/A	0.948	L/O Line 66-1 Graham - Epping BHE
<hr/>							
Sect 388	70014	PERC TAP	115	4	1.051	0	L/O Sect 388 Orrington - Maxcy's & Orrington T2
Sect 388	70035	L C P	115	5	1.051	0	L/O Sect 388 Orrington - Maxcy's & Orrington T2
Sect 388	90246	PERC 115	115	5	1.051	0	L/O Sect 388 Orrington - Maxcy's & Orrington T2
<hr/>							
Sect 396	70014	PERC TAP	115	4	0	1.05	L/O Sect 396 Orrington - Chester - Keswick w MIS SPS
Sect 396	70035	L C P	115	5	0	1.05	L/O Sect 396 Orrington - Chester - Keswick w MIS SPS
Sect 396	90246	PERC 115	115	5	0	1.051	L/O Sect 396 Orrington - Chester - Keswick w MIS SPS
Sect 396	90530	SV PAR	115	8	0	1.051	L/O Sect 396 Orrington - Chester - Keswick w MIS SPS

APPENDIX F – Short-Circuit Analysis Results

Appendix-F

Short Circuit Analysis from BHE

Fault Location:	Existing System					
	NRI OOS		NRI IS		Delta NRI IS (-) NRI OOS	
	<u>3 ph</u>	<u>ph-gnd</u>	<u>3 ph</u>	<u>ph-gnd</u>	<u>3 ph</u>	<u>ph-gnd</u>
Washington County						
- 115kv bus	1,991	1,381	1,995	1,383	4	2
- 34.5kv bus	5,903	7,020	5,909	7,026	6	6
Harrington						
- 115kv bus	2,223	1,727	2,230	1,729	7	2
- 34.5kv bus	4,286	4,529	4,293	4,534	7	5
Boggy Brook						
- 115kv bus	6,581	4,094	6,697	4,124	116	30

Fault Location:	Post Project					
	NRI OOS		NRI IS		Delta NRI IS (-) NRI OOS	
	<u>3 ph</u>	<u>ph-gnd</u>	<u>3 ph</u>	<u>ph-gnd</u>	<u>3 ph</u>	<u>ph-gnd</u>
Washington County						
- 115kv bus	2,533	1,674	2,543	1,676	10	2
- 34.5kv bus	6,589	7,663	6,600	7,673	11	10
Harrington						
- 115kv bus	3,515	2,544	3,538	2,552	23	8
- 34.5kv bus	4,867	4,953	4,878	4,961	11	8
Boggy Brook						
- 115kv bus	6,950	4,493	7,073	4,528	123	35

Fault Location:	Post Project (-) Existing System			
	NRI OOS		NRI IS	
	<u>3 ph</u>	<u>ph-gnd</u>	<u>3 ph</u>	<u>ph-gnd</u>
Washington County				
- 115kv bus	542	293	548	293
- 34.5kv bus	686	643	691	647
Harrington				
- 115kv bus	1,292	817	1,308	823
- 34.5kv bus	581	424	585	427
Boggy Brook				
- 115kv bus	369	399	376	404