

Northeast
Utilities System

May 17, 2010

VIA HAND DELIVERY

Kimberly D. Bose, Secretary
Nathaniel J. Davis, Sr., Acting Deputy Secretary
Federal Energy Regulatory Commission
888 First Street, N.E.
Washington, D.C. 20426

**RE: ISO New England Inc. and Public Service Company of New Hampshire –
Original Service Agreement No. LGIA-ISON/NU-10-03 under Schedule 22
of the ISO New England Inc.’s Open Access Transmission Tariff, and Notice
of Cancellation of ISO New England Inc. and Public Service Company of
New Hampshire Original Service Agreement No. LGIA-ISON/NU/08-06
under Schedule 22 of the ISO New England Inc.’s Open Access Transmission
Tariff
Docket No. ER10- -000**

Dear Secretary Bose and Deputy Secretary Davis:

Pursuant to Section 205 of the Federal Power Act, 16 U.S.C. § 824d, Part 35 of the Federal Energy Regulatory Commission’s (the “Commission”) regulations, 18 C.F.R. Part 35, and Order Nos. 2003, 2003-A, 2003-B and 2003-C,¹ ISO New England Inc. (the “ISO”) and Northeast Utilities Service Company (“NUSCO”), on behalf of its affiliate Public Service Company of New Hampshire (“PSNH”), (together, the “Filing Parties”)² hereby submit for filing

¹ *Standardization of Generator Interconnection Agreements and Procedures*, Order No. 2003, 68 Fed. Reg. 49,845 (Aug. 19, 2003), FERC Stats. & Regs. ¶ 31,146 (2003), *order on reh’g*, Order No. 2003-A, 69 Fed. Reg. 15,932 (Mar. 26, 2004), FERC Stats. & Regs., ¶ 31,160 (2004), *order on reh’g*, Order No. 2003-B, 70 Fed. Reg. 265 (Jan. 4, 2005), FERC Stats & Regs. ¶ 31,171 (2005), *order on reh’g*; Order No. 2003-C, 70 Fed. Reg. 37661 (June 30, 2005), FERC Stats. & Regs. ¶ 31,146 (2005); *see also Notice Clarifying Compliance Procedures*, 106 FERC ¶ 61,009 (2004).

² Section 11.3 of the Standard Large Generator Interconnection Procedures (“LGIP”) contained in Schedule 22 of Section II of the ISO’s Transmission, Markets and Services Tariff (“ISO Tariff”) provides that “the System Operator and Interconnecting Transmission Owner shall jointly file the executed LGIA, or amendments thereto,

(continued...)

this transmittal letter and six copies of: (i) an executed non-conforming Standard Large Generator Interconnection Agreement³ (the “New Interconnection Agreement”)⁴ by and between the ISO, as System Operator, and PSNH, as both the Interconnection Customer and the Interconnecting Transmission Owner, and (ii) notice cancelling the existing Standard Large Generator Interconnection Agreement (the “Original Interconnection Agreement”) between the ISO and PSNH.⁵

As described further in Section III, below, the New Interconnection Agreement replaces the Original Interconnection Agreement. Like the Original Interconnection Agreement, the New Interconnection Agreement proposes certain deviations from the *pro forma* LGIA included in Schedule 22 of the ISO OATT. As discussed in Section III, the Filing Parties request that the Commission accept the deviations proposed herein from the *pro forma* LGIA pertaining to PSNH’s status as both the Interconnection Customer and the Interconnecting Transmission Owner. The Filing Parties respectfully request that the Commission accept the New Interconnection Agreement and the notice cancelling the Original Interconnection Agreement for filing with a concurrent effective date of **May 31, 2010**.

I. DESCRIPTION OF THE FILING PARTIES; COMMUNICATIONS

The ISO is the private, non-profit entity that serves as the regional transmission organization (“RTO”) for New England. The ISO operates the New England bulk power system and administers New England’s organized wholesale electricity market pursuant to the ISO Tariff and operating agreements with transmission owners. In its capacity as an RTO, the ISO has the responsibility to protect the short-term reliability of the New England Control Area and to operate the system according to reliability standards established by the Northeast Power Coordinating Corporation (“NPCC”) and the North American Electric Reliability Council (“NERC”).

(...continued)

with the Commission under Section 205 of the Federal Power Act.” Consistent with Section 11.3 of the LGIP, the Filing Parties jointly file herein the Interconnection Agreements pursuant to Section 205 of the FPA.

³ Capitalized terms not defined in this filing letter have the meaning specified in the New Interconnection Agreement.

⁴ The New Interconnection Agreement has been designated as Original Service Agreement No. LGIA-ISONU-10-03 under the ISO Tariff. The New Interconnection Agreement is based on the currently effective Standard Large Generator Interconnection Agreement (“*pro forma* LGIA”) contained in Section II of the ISO Tariff, which is the Open Access Transmission Tariff (“ISO OATT”).

⁵ The Original Interconnection Agreement was designated as Original Service Agreement No. LGIA-ISONU-08-06 under the ISO Tariff. The Original Interconnection Agreement was based on the *pro forma* LGIA that was in effect at the time that it was executed.

PSNH is a transmission, distribution and generation company affiliate of NUSCO, and together with the other transmission-owning Northeast Utilities subsidiaries,⁶ provides transmission services pursuant to the ISO Tariff.

All correspondence and communications in this proceeding should be addressed to the undersigned for the ISO as follows:

Monica Gonzalez, Esq.
Regulatory Counsel
ISO New England Inc.
One Sullivan Road
Holyoke, MA 01040-2841
Tel: (413) 535-4178
Fax: (413) 535-4379
E-mail: mgonzalez@iso-ne.com

Daniel R. Simon, Esq.
Ballard Spahr Andrews & Ingersoll, LLP
601 13th Street, NW
Suite 1000 South
Washington, DC 20005-3807
Tel: (202) 661-2200
Fax: (202) 661-2299
E-mail: simond@ballardspahr.com

And to NUSCO as follows:

Michael J. Hall, Esq.
Senior Counsel
Northeast Utilities Service Company
P.O. Box 270
Hartford, CT 06141-0270
Tel: (860) 665-5546
Fax: (860) 665-5504
E-mail: hallmjx@nu.com

William O'Hara
Project Manager
Generator Interconnection & Services
Northeast Utilities Service Company
P.O. Box 270
Hartford, CT 06141-0270
Tel: (860) 665-2925
E-mail: oharaw@nu.com

II. INTRODUCTION

A. Description of the Large Generating Facility and Interconnection to the Administered Transmission System

The New Interconnection Agreement governs the interconnection of PSNH's Large Generating Facility, which is comprised of four existing generating units located at the Merrimack Generating Station in Bow, New Hampshire (Merrimack Units 1, 2, CT-1, and CT-2, or together, "Merrimack Station") to PSNH's transmission system. Merrimack Station is an existing generating facility that was constructed in 1960, and has been continuously owned by, and interconnected to, PSNH. As a utility owning generation connected to its own transmission system, an interconnection agreement was previously unnecessary.

⁶ The other Northeast Utilities transmission-owning subsidiaries are Western Massachusetts Electric Company, The Connecticut Light and Power Company, and Public Service Company of New Hampshire.

In 2005, in connection with the formation of a New England regional transmission organization, PSNH and other New England utilities turned over the operation of their transmission facilities to the ISO. Subsequently, in accordance with the Commission's Order Nos. 2003, 2003-A, -B and -C, and the Commission's approval of the ISO's procedures for generator interconnections,⁷ the ISO now administers the process for new interconnections to the Administered Transmission System, which includes certain modifications to existing generating facilities that are already interconnected to the Administered Transmission System.

On April 15, 2008, PSNH submitted to the ISO an Interconnection Request under Schedule 22 of the ISO OATT⁸ to increase the generating capacity of the existing Merrimack Unit No. 2 by approximately 4.675 megawatts (summer capacity). Pursuant to Schedule 22, and consistent with the Commission's generator interconnection procedures,⁹ the Filing Parties entered into the Original Interconnection Agreement. Because the Original Interconnection Agreement contained revisions to the *pro forma* LGIA, the Filing Parties filed it with the Commission for approval on December 16, 2008, in Docket No. ER09-420-000. The Commission accepted the Original Interconnection Agreement by letter order issued on February 3, 2009.

Meanwhile, on January 21, 2009, PSNH submitted to the ISO another Interconnection Request to further increase the generating capacity of the Merrimack Unit No. 2 by another approximately 17 megawatts (summer capacity). While this interconnection request was pending, the Commission issued an order accepting the new *pro forma* LGIA filed by the ISO on October 31, 2009, in Docket Nos. ER09-237-000, *et al.*, to become effective on February 1, 2009.¹⁰ This required the Filing Parties to enter into a new interconnection agreement that conforms to the *pro forma* LGIA that took effect on February 1, 2009.¹¹ Accordingly, the Filing Parties developed and entered into the New Interconnection Agreement, which supersedes the Original Interconnection Agreement.

⁷ *New England Power Pool*, 109 FERC ¶ 61,155 (2004), *accepting compliance filing*, 110 FERC ¶ 61,335 (2005).

⁸ In accordance with Schedule 22 of the ISO OATT, a new Interconnection Request, and therefore a new three-party LGIA, is required "to increase the capacity of . . . an existing Generating Facility that is interconnected with the Administered Transmission System." See Schedule 22, Section 1 (definition of Interconnection Request).

⁹ See Order Nos. 2003 at P 4 and n. 5; see also *Midwest Independent Transmission System Operator, Inc.*, 125 FERC ¶ 61,210 (2008); *New England Power Co.*, 109 FERC ¶ 61,364 at P 12 (2004).

¹⁰ See *ISO New England Inc. and New England Power Pool*, 126 FERC ¶ 61,080 (2009).

¹¹ See *Midwest Independent Transmission System Operator, Inc.*, 125 FERC ¶ 61, 277 at PP 10, 12 (2008).

B. The Need to File the New Interconnection Agreement

Pursuant to Order No. 2003, “non-conforming [interconnection] agreements . . . must be filed with the Commission for approval before going into effect” including “agreements that do not precisely match the applicable standard form of service agreement.”¹² As discussed in Section III below, the New Interconnection Agreement contains revisions to the *pro forma* LGIA that are warranted by the unique characteristics of the Large Generating Facility’s interconnection to the Administered Transmission System, thus requiring it to be filed with the Commission.

III. DISCUSSION

In various orders, the Commission has provided guidance regarding deviations from the applicable standard form of service agreement – the ISO’s *pro forma* LGIA. Specifically, the Commission has stated that where a case-specific deviation from a *pro forma* interconnection agreement is sought, justification explaining what makes the interconnection unique and what operational concerns or other reasons necessitate the changes, including reliability concerns, novel legal issues or other unique factors, must be provided.¹³ The New Interconnection Agreement is unique because it provides for the interconnection of PSNH’s Large Generating Facility to the Administered Transmission System with PSNH as both the Interconnection Customer and the Interconnecting Transmission Owner.

To recognize PSNH’s unique status, the Filing Parties propose the following deviations from the *pro forma* LGIA: (i) creating a two (instead of three) party interconnection agreement, and (ii) replacing the “Point of Change of Ownership” with “Point of Change of Function.”

A. Two-Party vs. Three-Party Interconnection Agreement

The New Interconnection Agreement has been revised to reflect a two-party agreement, as opposed to the three-party agreement provided as the ISO’s *pro forma* LGIA. Order No. 2003 permits a two-party agreement where the “Transmission Provider” is the same as the “Transmission Owner.”¹⁴ The ISO’s *pro forma* LGIA provides for a three-party agreement to distinguish the ISO, as the System Operator, from the Transmission Owner. Here, however, the Interconnection Customer is the same entity as the Transmission Owner. Thus, certain non-

¹² Order No. 2003 at P 914.

¹³ See *Midwest Independent Transmission System Operator, Inc.*, 111 FERC ¶ 61,421 at P 11 (2005) (citing Order No. 2003 at PP 913-15).

¹⁴ Order No. 2003 at PP 908-09; see also, *ISO New England Inc.*, 125 FERC ¶ 61,224 at PP 3, 8 (2008) (accepting similar revisions to the *pro forma* LGIA).

conforming provisions are necessary to reflect a two-party agreement. The proposed non-conforming provisions are highlighted in Attachment 2, which provides a redlined version of the sheets that propose deviations from the current *pro forma* LGIA in Schedule 22 of the ISO OATT. The proposed deviations are, particularly, in: (1) the preamble, (2) the “Whereas” clauses, and (3) the signature page.

B. Interconnection Facilities Provisions

The Filing Parties also propose revisions to the New Interconnection Agreement to replace the “Point of Change of Ownership” with “Point of Change of Function.” Under Article 1 of the *pro forma* LGIA:

Point of Change of Ownership shall mean the point, as set forth in Appendix A to the Standard Large Generator Interconnection Agreement, where the Interconnection Customer’s Interconnection Facilities connect to the Interconnecting Transmission Owner’s Interconnection Facilities.

Here, as explained above, the Interconnection Facilities are owned by PSNH. Accordingly, there is no “Point of Change of Ownership.”¹⁵

There is, however, an operational need to provide a point of demarcation between the facilities that would normally be associated with the Interconnection Customer and those that would be associated with the Interconnecting Transmission Owner. As shown in Appendix A -1 through A-3 of the LGIA, the facilities generally known as the “Interconnection Customer’s Interconnection Facilities” are those facilities between the generating unit and up to, but excluding control of, the breaker at the point designated as both the “Point of Change of Function” and “Point of Interconnection.” The remaining facilities shown in Appendix A-1 through A-3 of the LGIA at, and beyond, the Point of Interconnection are what are generally known as the “Interconnecting Transmission Owner’s Transmission Facilities.” The term “Point of Change of Function” accurately reflects the necessary delineation of these facilities.

To reflect the change in terminology from “Point of Change of Ownership” to “Point of Change of Function,” the Filing Parties propose to revise the following definitions in Article 1 of the Interconnection Agreement: (1) “Interconnecting Transmission Owner’s Interconnection Facilities,” (2) “Interconnection Customer’s Interconnection Facilities,” and (3) “Point of Change of Ownership.” These minor revisions, shown in redline text in Attachment 2, are necessary to the unique characteristics of this interconnection and provide clarity on the demarcation of the Interconnection Facilities, avoiding potential future confusion.

¹⁵ See *ISO New England Inc.*, 125 FERC at PP 3, 8 (accepting similar revisions to the *pro forma* LGIA).

C. Notice of Cancellation

As discussed in Section II, the New Interconnection Agreement supersedes the Original Service Agreement. Consequently, the Filing Parties also provide notice to cancel the Original Service Agreement and respectfully request that the cancellation be made effective as of May 31, 2010, to coincide with the effective date of the New Interconnection Agreement.

IV. REQUESTED EFFECTIVE DATE AND WAIVERS

The Filing Parties respectfully request that the Commission accept the New Interconnection Agreement and the notice cancelling the Original Interconnection Agreement, without modifications or conditions, with an effective date of May 31, 2010. This will allow the New Interconnection Agreement to be in effect prior to the commercial operation date of the increase to PSNH's Merrimack Unit No. 2. The Filing Parties respectfully request any waivers of the Commission's regulations, including but not limited to, 18 C.F.R. § 35.3, 35.11, and 35.15, that may be necessary to permit such an effective date. Such a waiver will have no adverse effect on any party. The Commission has granted waivers when "all affected parties have had sufficient notice that [the] change will be incorporated into the [Tariff]."¹⁶ Therefore, the Filing Parties respectfully submit that good cause exists to grant waiver of the 60-day prior notice requirement pursuant to 18 C.F.R. § 35.11. To the extent the Commission finds otherwise, the Filing Parties respectfully request as early an effective date as the Commission may allow.

V. CONTENTS OF THE FILING

This filing includes an original and six (6) copies of the following:

- this transmittal letter;
- the executed New Interconnection Agreement (Attachment 1);
- sheets from the New Interconnection Agreement in redline format with deviations from the current *pro forma* LGIA (Attachment 2); and
- Revised sheet to the Original Service Agreement under Schedule 22 of the ISO Tariff (Attachment 3).

¹⁶ *California Independent System Operator Corp.*, 111 FERC ¶ 61,073 at P 26 (2005).

VI. CONCLUSION

For the foregoing reasons, the Filing Parties respectfully request that the Commission grant the requested waivers and accept the New Interconnection Agreement and the notice cancelling the Original Service Agreement for filing with an effective date of May 31, 2010, or soon thereafter as the Commission may allow.

Very truly yours,

NORTHEAST UTILITIES SERVICE COMPANY
AND PUBLIC SERVICE COMPANY OF NEW
HAMPSHIRE

By: Michael J. Hall, Esq. /JMS
Michael J. Hall, Esq.

Senior Counsel
Northeast Utilities Service Company
107 Selden Street
Berlin, CT 06037
Tel: (860) 665-5546

Counsel for Northeast Utilities Service
Company and Public Service Company of New
Hampshire

and

ISO NEW ENGLAND INC.

By: Monica Gonzalez, Esq. /JMS
Monica Gonzalez, Esq.

Regulatory Counsel
ISO New England Inc.
One Sullivan Road
Holyoke, MA 01040-2841
Tel: (413) 413-535-4178

Counsel for ISO New England Inc.

Attachment 1

ISO New England Inc.
FERC Electric Tariff No. 3
Open Access Transmission Tariff
Schedule 22 – Large Generator Interconnection Agreement

Original Service Agreement No. LGIA-ISONE/NU-10-03

STANDARD LARGE GENERATOR INTERCONNECTION AGREEMENT

BY AND AMONG

ISO-NEW ENGLAND INC.

AND

PUBLIC SERVICE COMPANY OF NEW HAMPSHIRE

Issued by: Raymond W. Hepper
Vice President and General Counsel
Issued on: May 17, 2010

Effective Date: May 31, 2010

TABLE OF CONTENTS

ARTICLE 1. DEFINITIONS.....	4
ARTICLE 2. EFFECTIVE DATE, TERM AND TERMINATION	16
ARTICLE 3. REGULATORY FILINGS	19
ARTICLE 4. SCOPE OF SERVICE	19
ARTICLE 5. INTERCONNECTION FACILITIES ENGINEERING, PROCUREMENT, AND CONSTRUCTION.....	23
ARTICLE 6. TESTING AND INSPECTION	42
ARTICLE 7. METERING.....	43
ARTICLE 8. COMMUNICATIONS.....	44
ARTICLE 9. OPERATIONS.....	45
ARTICLE 10. MAINTENANCE	51
ARTICLE 11. PERFORMANCE OBLIGATION	52
ARTICLE 12. INVOICE	54
ARTICLE 13. EMERGENCIES.....	55
ARTICLE 14. REGULATORY REQUIREMENTS AND GOVERNING LAW	58
ARTICLE 15. NOTICES.....	58
ARTICLE 16. FORCE MAJEURE	59
ARTICLE 17. DEFAULT	59
ARTICLE 18. INDEMNITY, CONSEQUENTIAL DAMAGES AND INSURANCE	60
ARTICLE 19. ASSIGNMENT	64
ARTICLE 20. SEVERABILITY	65
ARTICLE 21. COMPARABILITY.....	65
ARTICLE 22. CONFIDENTIALITY.....	65
ARTICLE 23. ENVIRONMENTAL RELEASES	69
ARTICLE 24. INFORMATION REQUIREMENTS.....	70
ARTICLE 25. INFORMATION ACCESS AND AUDIT RIGHTS.....	72
ARTICLE 26. SUBCONTRACTORS	73
ARTICLE 27. DISPUTES	74
ARTICLE 28. REPRESENTATIONS, WARRANTIES AND COVENANTS	75
ARTICLE 29. [OMITTED].....	76
ARTICLE 30. MISCELLANEOUS	76

THIS STANDARD LARGE GENERATOR INTERCONNECTION AGREEMENT (“Agreement”) is made and entered into this 17th day of May 2010, by and between Public Service Company of New Hampshire, a public service company organized and existing under the laws of the State of New Hampshire, (herein known as both “Interconnection Customer” with a Large Generating Facility and “Interconnecting Transmission Owner”) and ISO New England Inc., a non-stock corporation organized and existing under the laws of the State of Delaware (“System Operator”). Under this Agreement the Interconnection Customer, System Operator, and Interconnecting Transmission Owner each may be referred to as a “Party” or collectively as the “Parties.”

RECITALS

WHEREAS, System Operator is the central dispatching agency provided for under the Transmission Operating Agreement (“TOA”) which has responsibility for the operation of the New England Control Area from the System Operator control center and the administration of the Tariff; and

WHEREAS, Interconnecting Transmission Owner is the owner or possessor of an interest in the Administered Transmission System; and

WHEREAS, Interconnection Customer intends to own, lease and/or control and operate the Generating Facility identified as a Large Generating Facility in Appendix C to this Agreement; and

WHEREAS, System Operator, and Public Service Company of New Hampshire as both Interconnection Customer and Interconnecting Transmission Owner have agreed to enter into this Agreement for the purpose of interconnecting the Large Generating Facility to the Administered Transmission System.

NOW, THEREFORE, in consideration of and subject to the mutual covenants contained herein, it is agreed:

When used in this Standard Large Generator Interconnection Agreement, terms with initial capitalization that are not defined in Article 1 shall have the meanings specified in the Article in which they are used.

ARTICLE 1. DEFINITIONS

The definitions contained in this Article 1 and those definitions embedded in an Article of this Agreement are intended to apply in the context of the generator interconnection process provided for in Schedule 22 (and its appendices). To the extent that the definitions herein are different than those contained in Sections I.2.2 of the Tariff, the definitions provided below shall control only for purposes of generator interconnections under Schedule 22. Capitalized terms in Schedule 22 that are not defined in this Section 1 shall have the meanings specified in Sections I.2.2 of the Tariff.

Administered Transmission System shall mean the PTF, the Non-PTF, and distribution facilities that are subject to the Tariff.

Adverse System Impact shall mean any significant negative effects on the stability, reliability or operating characteristics of the electric system.

Affected System shall mean any electric system that is within the Control Area, including, but not limited to, generator owned transmission facilities, or any other electric system that is not within the Control Area that may be affected by the proposed interconnection.

Affected Party or Parties shall mean the entity that owns, operates or controls an Affected System, or any other entity that otherwise may be a necessary party to the interconnection process.

Affiliate shall mean, with respect to a corporation, partnership or other entity, each such other corporation, partnership or other entity that directly or indirectly, through one or more intermediaries, controls, is controlled by, or is under common control with, such corporation, partnership or other entity.

Applicable Laws and Regulations shall mean all duly promulgated applicable federal, state and local laws, regulations, rules, ordinances, codes, decrees, judgments, directives, or judicial or administrative orders, permits and other duly authorized actions of any Governmental Authority.

Applicable Reliability Council shall mean the reliability council applicable to the New England Transmission System.

Applicable Reliability Standards shall mean the requirements and guidelines of NERC, the NPCC and the New England Control Area, including publicly available local reliability requirements of Interconnecting Transmission Owners or other Affected Parties.

At-Risk Expenditure shall mean money expended for the development of the Generating Facility that cannot be recouped if the Interconnection Customer were to withdraw the Interconnection Request for the Generating Facility. At-Risk Expenditure may include, but is not limited to, money expended on: (i) costs of federal, state, local, regional and town permits, (ii) Site Control, (iii) site-specific design and surveys, (iv) construction activities, and (v) non-refundable deposits for major equipment components. For purposes of this definition, At-Risk Expenditure shall not include costs associated with the Interconnection Studies.

Base Cases shall have the meaning specified in Section 2.3 of the Large Generator Interconnection Procedures (“LGIP”).

Base Case Data shall mean the base case power flow, short circuit, and stability data bases used for the Interconnection Studies by the System Operator, Interconnection Customer, Interconnecting Transmission Owner, or any Affected Party as deemed appropriate by the System Operator in accordance with applicable codes of conduct and confidentiality requirements.

Breach shall mean the failure of a Party to perform or observe any material term or condition of the Standard Large Generator Interconnection Agreement.

Breaching Party shall mean a Party that is in Breach of the Standard Large Generator Interconnection Agreement.

Calendar Day shall mean any day including Saturday, Sunday or a Federal Holiday.

Capacity Capability Interconnection Standard (“CC Interconnection Standard”) shall mean the criteria required to permit the Interconnection Customer to interconnect in a manner that avoids any significant adverse effect on the reliability, stability, and operability of the New England Transmission System, including protecting against the degradation of transfer capability for interfaces affected by the Generating Facility, and in a manner that ensures intra-zonal deliverability by avoidance of the redispatch of other Capacity Network Resources, as detailed in the ISO New England Planning Procedures.

Capacity Network Resource (“CNR”) shall mean that portion of a Generating Facility that is interconnected to the Administered Transmission System under the Capacity Capability Interconnection Standard.

Capacity Network Resource Capability (“CNR Capability”) shall mean: (i) in the case of a Generating Facility that is a New Generating Capacity Resource pursuant to Section

III.13.1 of the Tariff or an Existing Generating Capacity Resource that is increasing its capability pursuant to Section III.13.1.2.2.5 of the Tariff, the highest megawatt amount of the Capacity Supply Obligation obtained by the Generating Facility in accordance with Section III.13 of the Tariff, and, if applicable, as specified in a filing by the System Operator with the Commission in accordance with Section III.13.8.2 of the Tariff, or (ii) in the case of a Generating Facility that meets the criteria under Section 5.2.3 of this LGIP, the total megawatt amount reflected in an existing Interconnection Agreement, whether executed or filed in unexecuted form with the Commission, an application pursuant to Section I.3.9 of the Tariff (or its predecessor provision, if any), or as determined by the System Operator based on documented historic capability of the Generating Facility. CNR Capability shall not exceed the maximum net megawatt electrical output of the Generating Facility at an ambient temperature at or above 90 F. degrees for Summer and at or above 20 degrees F. for Winter. Where the Generating Facility includes multiple production devices, the CNR Capability shall not exceed the aggregate maximum net megawatt electrical output of the Generating Facility at an ambient temperature at or above 90 degrees F. for Summer and at or above 20 degrees F. for Winter.

Capacity Network Resource Group Study (“CNR Group Study”) shall mean the study performed by the System Operator under Section III.13.1.1.2.3 of the Tariff to determine which resources qualify to participate in a Forward Capacity Auction.

Capacity Network Resource Interconnection Service (“CNR Interconnection Service”) shall mean the Interconnection Service selected by the Interconnection Customer to interconnect its Large Generating Facility with the Administered Transmission System in accordance with the Capacity Capability Interconnection Standard. An Interconnection Customer’s CNR Interconnection Service shall be for the megawatt amount of CNR Capability. CNR Interconnection Service does not in and of itself convey transmission service.

Clustering shall mean the process whereby a group of Interconnection Requests is studied together for the purpose of conducting the Interconnection System Impact Study.

Commercial Operation shall mean the status of a Generating Facility that has commenced generating electricity for sale, excluding electricity generated during Trial Operation.

Commercial Operation Date of a unit shall mean the date on which the Generating Facility commences Commercial Operation as agreed to by the Parties pursuant to Appendix E to the Standard Large Generator Interconnection Agreement.

Conditional Qualified New Generating Capacity Resource shall be as defined in Section III.13.1.1.2.3(f) of the Tariff.

Confidential Information shall mean any confidential, proprietary or trade secret information of a plan, specification, pattern, procedure, design, device, list, concept, policy or compilation relating to the present or planned business of a Party, which is designated as confidential by the Party supplying the information, whether conveyed orally, electronically, in writing, through inspection, or otherwise. Confidential Information shall include, but not be limited to, information that is confidential pursuant to the ISO New England Information Policy.

Cost of New Entry (“CONE”) shall be as determined in Section III.13.2.4 of the Tariff.

Default shall mean the failure of a Breaching Party to cure its Breach in accordance with Article 17 of the Standard Large Generator Interconnection Agreement.

Dispute Resolution shall mean the procedure for resolution of a dispute between the Parties in which they will first attempt to resolve the dispute on an informal basis.

Distribution System shall mean the Interconnecting Transmission Owner’s facilities and equipment used to transmit electricity to ultimate usage points such as homes and industries directly from nearby generators or from interchanges with higher voltage transmission networks which transport bulk power over longer distances. The voltage levels at which distribution systems operate differ among areas.

Distribution Upgrades shall mean the additions, modifications, and upgrades to Interconnecting Transmission Owner’s Distribution System at or beyond the Point of Interconnection to facilitate interconnection of the Generating Facility and render the transmission service necessary to effect Interconnection Customer’s wholesale sale of electricity in interstate commerce. Distribution Upgrades do not include Interconnection Facilities.

Effective Date shall mean the date on which the Standard Large Generator Interconnection Agreement becomes effective upon execution by the Parties subject to acceptance by the Commission or if filed unexecuted, upon the date specified by the Commission.

Emergency Condition shall mean a condition or situation: (1) that in the judgment of the Party making the claim is likely to endanger life or property; or (2) that, in the case of the Interconnecting Transmission Owner, is likely (as determined in a non-discriminatory manner) to cause a material adverse effect on the security of, or damage to the New England Transmission System, Interconnecting Transmission Owner’s Interconnection Facilities or any Affected System to which the New England Transmission System is directly connected; or (3) that, in the case of Interconnection Customer, is likely (as determined in a non-discriminatory manner) to

cause a material adverse effect on the security of, or damage to, the Generating Facility or Interconnection Customer's Interconnection Facilities. System restoration and black start shall be considered Emergency Conditions; provided that Interconnection Customer is not obligated by the Standard Large Generator Interconnection Agreement to possess black start capability.

Engineering & Procurement (“E&P”) Agreement shall mean an agreement that authorizes the Interconnection Customer, Interconnecting Transmission Owner and any other Affected Party to begin engineering and procurement of long lead-time items necessary for the establishment of the interconnection in order to advance the implementation of the Interconnection Request.

Environmental Law shall mean Applicable Laws or Regulations relating to pollution or protection of the environment or natural resources.

Federal Power Act shall mean the Federal Power Act, as amended, 16 U.S.C. §§ 791a *et seq.*

Force Majeure shall mean any act of God, labor disturbance, act of the public enemy, war, insurrection, riot, fire, storm or flood, explosion, breakage or accident to machinery or equipment, any order, regulation or restriction imposed by governmental, military or lawfully established civilian authorities, or any other cause beyond a Party's control. A Force Majeure event does not include acts of negligence or intentional wrongdoing by the Party claiming Force Majeure.

Generating Facility shall mean Interconnection Customer's device for the production of electricity identified in the Interconnection Request, but shall not include the Interconnection Customer's Interconnection Facilities.

Good Utility Practice shall mean any of the practices, methods and acts engaged in or approved by a significant portion of the electric industry during the relevant time period, or any of the practices, methods and acts which, in the exercise of reasonable judgment in light of the facts known at the time the decision was made, could have been expected to accomplish the desired result at a reasonable cost consistent with good business practices, reliability, safety and expedition. Good Utility Practice is not intended to be limited to the optimum practice, method, or act to the exclusion of all others, but rather to be acceptable practices, methods, or acts generally accepted in the region.

Governmental Authority shall mean any federal, state, local or other governmental regulatory or administrative agency, court, commission, department, board, or other governmental subdivision, legislature, rulemaking board, tribunal, or other governmental authority having jurisdiction over the Parties, their respective facilities, or the respective services

they provide, and exercising or entitled to exercise any administrative, executive, police, or taxing authority or power; provided, however, that such term does not include the System Operator, Interconnection Customer, Interconnecting Transmission Owner, or any Affiliate thereof.

Hazardous Substances shall mean any chemicals, materials or substances defined as or included in the definition of “hazardous substances,” “hazardous wastes,” “hazardous materials,” “hazardous constituents,” “restricted hazardous materials,” “extremely hazardous substances,” “toxic substances,” “radioactive substances,” “contaminants,” “pollutants,” “toxic pollutants” or words of similar meaning and regulatory effect under any applicable Environmental Law, or any other chemical, material or substance, exposure to which is prohibited, limited or regulated by any applicable Environmental Law.

Initial Synchronization Date shall mean the date upon which the Generating Facility is initially synchronized and upon which Trial Operation begins.

In-Service Date shall mean the date upon which the Interconnection Customer reasonably expects it will be ready to begin use of the Interconnecting Transmission Owner’s Interconnection Facilities to obtain back feed power.

Interconnecting Transmission Owner shall mean a Transmission Owner that owns, leases or otherwise possesses an interest in the portion of the Administered Transmission System at the Point of Interconnection and shall be a Party to the Standard Large Generator Interconnection Agreement. The term Interconnecting Transmission Owner shall not be read to include the System Operator.

Interconnecting Transmission Owner’s Interconnection Facilities shall mean all facilities and equipment owned, controlled, or operated by Interconnecting Transmission Owner from the Point of Change of Function to the Point of Interconnection as identified in Appendix A to the Standard Large Generator Interconnection Agreement, including any modifications, additions or upgrades to such facilities and equipment. Interconnecting Transmission Owner’s Interconnection Facilities are sole use facilities and shall not include Distribution Upgrades, Stand Alone Network Upgrades or Network Upgrades.

Interconnection Customer shall mean any entity, including a transmission owner or its Affiliates or subsidiaries, that proposes to interconnect its Generating Facility with the Administered Transmission System.

Interconnection Customer's Interconnection Facilities shall mean all facilities and equipment, as identified in Appendix A of the Standard Large Generator Interconnection Agreement, that are located between the Generating Facility and the Point of Change of Function, including any modification, addition, or upgrades to such facilities and equipment necessary to physically and electrically interconnect the Generating Facility to the Administered Transmission System. Interconnection Customer's Interconnection Facilities are sole use facilities.

Interconnection Facilities shall mean the Interconnecting Transmission Owner's Interconnection Facilities and the Interconnection Customer's Interconnection Facilities. Collectively, Interconnection Facilities include all facilities and equipment between the Generating Facility and the Point of Interconnection, including any modification, additions or upgrades that are necessary to physically and electrically interconnect the Generating Facility to the Administered Transmission System. Interconnection Facilities are sole use facilities and shall not include Distribution Upgrades, Stand Alone Network Upgrades or Network Upgrades.

Interconnection Facilities Study shall mean a study conducted by the System Operator, Interconnecting Transmission Owner, or a third party consultant for the Interconnection Customer to determine a list of facilities (including Interconnecting Transmission Owner's Interconnection Facilities and Network Upgrades as identified in the Interconnection System Impact Study), the cost of those facilities, and the time required to interconnect the Generating Facility with the Administered Transmission System. The scope of the study is defined in Section 8 of the Standard Large Generator Interconnection Procedures.

Interconnection Facilities Study Agreement shall mean the form of agreement contained in Appendix 4 of the Standard Large Generator Interconnection Procedures for conducting the Interconnection Facilities Study.

Interconnection Feasibility Study shall mean a preliminary evaluation of the system impact and cost of interconnecting the Generating Facility to the Administered Transmission System, the scope of which is described in Section 6 of the Standard Large Generator Interconnection Procedures. The Interconnection Customer has the option to request either that the Interconnection Feasibility Study be completed as a separate and distinct study, or as part of the Interconnection System Impact Study. If the Interconnection Customer requests that the Interconnection Feasibility Study be completed as part of the Interconnection System Impact Study, Section 6 shall be performed as the first step of the Interconnection System Impact Study, and shall be regarded as part of the Interconnection System Impact Study. When the requirements of Section 6 are performed as part of the Interconnection System Impact Study, the

Interconnection Customer shall be responsible only for the deposit requirements of the Interconnection System Impact Study, and there shall be only one final report, which will include the results of both Section 6 and Section 7.

Interconnection Feasibility Study Agreement shall mean the form of agreement contained in Appendix 2 of the Standard Large Generator Interconnection Procedures for conducting the Interconnection Feasibility Study.

Interconnection Request (a) shall mean an Interconnection Customer's request, in the form of Appendix 1 to the Standard Large Generator Interconnection Procedures, in accordance with the Tariff, to: (i) interconnect a new Generating Facility to the Administered Transmission System as either a CNR or a NR; (ii) increase the energy capability or capacity capability of an existing Generating Facility; (iii) make a Material Modification to the design or operating characteristics of an existing Generating Facility, including its Interconnection Facilities, that is interconnected with the Administered Transmission System; (iv) commence participation in the wholesale markets by an existing Generating Facility that is interconnected with the Administered Transmission System; or (v) change from NR Interconnection Service to CNR Interconnection Service. Interconnection Request shall not include: (i) a retail customer interconnecting a new Generating Facility that will produce electric energy to be consumed only on the retail customer's site; (ii) a request to interconnect a new Generating Facility to a distribution facility that is subject to the Tariff if the Generating Facility will not be used to make wholesale sales of electricity in interstate commerce; or (iii) a request to interconnect a Qualifying Facility (as defined by the Public Utility Regulatory Policies Act, as amended by the Energy Policy Act of 2005 and the regulations thereto), where the Qualifying Facility's owner intent is to sell 100% of the Qualifying Facility's output to its interconnected electric utility.

Interconnection Service shall mean the service provided by System Operator and the Interconnecting Transmission Owner, associated with interconnecting the Interconnection Customer's Generating Facility to the Administered Transmission System and enabling the receipt of electric energy capability and/or capacity capability from the Generating Facility at the Point of Interconnection, pursuant to the terms of the Standard Large Generator Interconnection Agreement and, if applicable, the Tariff.

Interconnection Study shall mean any of the following studies: the Interconnection Feasibility Study, the Interconnection System Impact Study, and the Interconnection Facilities Study described in the Standard Large Generator Interconnection Procedures. Interconnection Study shall not include a CNR Group Study.

Interconnection System Impact Study shall mean an engineering study that evaluates the impact of the proposed interconnection on the safety and reliability of the Administered

Transmission System and any other Affected System. The study shall identify and detail the system impacts that would result if the Generating Facility were interconnected without project modifications or system modifications, focusing on Adverse System Impacts, or to study potential impacts, including but not limited to those identified in the Scoping Meeting as described in the Standard Large Generator Interconnection Procedures. If the Interconnection Customer requests that the Interconnection Feasibility Study be completed as part of the Interconnection System Impact Study, Section 6 shall be performed as the first step of the Interconnection System Impact Study, and shall be regarded as part of the Interconnection System Impact Study. When the requirements of Section 6 are performed as part of the Interconnection System Impact Study, the Interconnection Customer shall be responsible only for the deposit requirements of the Interconnection System Impact Study, and there shall be only one final report, which will include the results of both Section 6 and Section 7.

Interconnection System Impact Study Agreement shall mean the form of agreement contained in Appendix 3 of the Standard Large Generator Interconnection Procedures for conducting the Interconnection System Impact Study.

IRS shall mean the Internal Revenue Service.

Large Generating Facility shall mean a Generating Facility having a maximum gross capability at or above zero degrees F. of more than 20 MW.

Long Lead Time Generating Facility (“Long Lead Facility”) shall mean a Generating Facility with an Interconnection Request for CNR Interconnection Service that has, as applicable, elected or requested long lead time treatment and met the eligibility criteria and requirements specified in Section 3.2.3 of the LGIP.

Loss shall mean any and all losses relating to injury to or death of any person or damage to property, demand, suits, recoveries, costs and expenses, court costs, attorney fees, and all other obligations by or to third parties, arising out of or resulting from another Party’s performance, or non-performance of its obligations under the Standard Large Generator Interconnection Agreement on behalf of the Indemnifying Party, except in cases of gross negligence or intentional wrongdoing by the Indemnifying Party.

Major Permits shall be as defined in Section III.13.1.1.2.2.2(a) of the Tariff.

Material Modification shall mean (i) except as expressly provided in Section 4.4.1, those modifications to the Interconnection Request, including any of the technical data provided by the Interconnection Customer in Attachment A to the Interconnection Request or to the interconnection configuration, requested by the Interconnection Customer that either require significant additional study of the same Interconnection Request and could substantially change the interconnection design, or have a material impact on the cost or timing of any

Interconnection Studies or upgrades associated with an Interconnection Request with a later queue priority date; (ii) a change to the design or operating characteristics of an existing Generating Facility, including its Interconnection Facilities, that is interconnected with the Administered Transmission System that may have a significant adverse effect on the reliability or operating characteristics of the New England Transmission System; (iii) a delay to the Commercial Operation Date, In-Service Date, or Initial Synchronization Date of greater than three (3) years where the reason for delay is unrelated to construction schedules or permitting which delay is beyond the Interconnection Customer's control; or (iv) except as provided in Section 3.2.3.4 of the LGIP, a withdrawal of a request for Long Lead Facility treatment; or (v) except as provided in Section 3.2.3.6 of the LGIP, an election to participate in an earlier Forward Capacity Auction than originally anticipated.

Metering Equipment shall mean all metering equipment installed or to be installed at the Generating Facility pursuant to the Standard Large Generator Interconnection Agreement at the metering points, including but not limited to instrument transformers, MWh-meters, data acquisition equipment, transducers, remote terminal unit, communications equipment, phone lines, and fiber optics.

NERC shall mean the North American Electric Reliability Council or its successor organization.

Network Capability Interconnection Standard (“NC Interconnection Standard”) shall mean the criteria required to permit the Interconnection Customer to interconnect in a manner that avoids any significant adverse effect on the reliability, stability, and operability of the New England Transmission System, including protecting against the degradation of transfer capability for interfaces affected by the Generating Facility, and in a manner that avoids the redispatch of other Network Resources, as detailed in the ISO New England Planning Procedures.

Network Resource (“NR”) shall mean the portion of a Generating Facility that is interconnected to the Administered Transmission System under the Network Capability Interconnection Standard.

Network Resource Capability (“NR Capability”) shall mean the maximum gross and net megawatt electrical output of the Generating Facility at an ambient temperature at or above 50 degrees F. for Summer and at or above 0 degrees F. for Winter. Where the Generating Facility includes multiple energy production devices, the NR Capability shall be the aggregate maximum gross and net megawatt electrical output of the Generating Facility at an ambient

temperature at or above 50 degrees F. for Summer and at or above 0 degrees F. for Winter. NR Capability shall be equal to or greater than the CNR Capability.

Network Resource Interconnection Service (“NR Interconnection Service”) shall mean the Interconnection Service selected by the Interconnection Customer to interconnect its Generating Facility to the Administered Transmission System in accordance with the Network Capability Interconnection Standard. An Interconnection Customer’s NR Interconnection Service shall be solely for the megawatt amount of the NR Capability. NR Interconnection Service in and of itself does not convey transmission service.

Network Upgrades shall mean the additions, modifications, and upgrades to the New England Transmission System required at or beyond the Point of Interconnection to accommodate the interconnection of the Large Generating Facility to the Administered Transmission System.

Notice of Dispute shall mean a written notice of a dispute or claim that arises out of or in connection with the Standard Large Generator Interconnection Agreement or its performance.

Optional Interconnection Study shall mean a sensitivity analysis based on assumptions specified by the Interconnection Customer in the Optional Interconnection Study Agreement.

Optional Interconnection Study Agreement shall mean the form of agreement contained in Appendix 5 of the Standard Large Generator Interconnection Procedures for conducting the Optional Interconnection Study.

Party or Parties shall mean the System Operator, Interconnection Customer and Interconnecting Transmission Owner or any combination of the above.

Point of Change of Function shall mean the point, as set forth in Appendix A to the Standard Large Generator Interconnection Agreement, where the Interconnection Customer’s Interconnection Facilities connect to Interconnecting Transmission Owner’s Interconnection Facilities.

Point of Interconnection shall mean the point, as set forth in Appendix A to the Standard Large Generator Interconnection Agreement, where the Interconnection Facilities connect to the Administered Transmission System.

Queue Position shall mean the order of a valid request in the New England Control Area, relative to all other pending requests in the New England Control Area, that is established based upon the date and time of receipt of such request by the System Operator. Requests are comprised of Interconnection Requests, requests for Elective Transmission Upgrades, requests

for transmission service and notification of requests for interconnection to other electric systems, as notified by the other electric systems, that impact the Administered Transmission System. For purposes of this LGIA, references to a “higher-queued” Interconnection Request shall mean one that has been received by the System Operator (and placed in queue order) earlier than another Interconnection Request, which is referred to as “lower-queued.”

Reasonable Efforts shall mean, with respect to an action required to be attempted or taken by a Party under the Standard Large Generator Interconnection Agreement, efforts that are timely and consistent with Good Utility Practice and are otherwise substantially equivalent to those a Party would use to protect its own interests.

Scoping Meeting shall mean the meeting between representatives of the System Operator, Interconnection Customer, Interconnecting Transmission Owner, or any Affected Party as deemed appropriate by the System Operator in accordance with applicable codes of conduct and confidentiality requirements, conducted for the purpose of discussing alternative interconnection options, to exchange information including any transmission data and earlier study evaluations that would be reasonably expected to impact such interconnection options, to analyze such information, and to determine the potential feasible Points of Interconnection.

Site Control shall mean documentation reasonably demonstrating: (a) that the Interconnection Customer is the owner in fee simple of the real property for which new interconnection is sought; (b) that the Interconnection Customer holds a valid written leasehold interest in the real property for which new interconnection is sought; (c) that the Interconnection Customer holds a valid written option to purchase or leasehold property for which new interconnection is sought; (d) that the Interconnection Customer holds a duly executed written contract to purchase or leasehold the real property for which new interconnection is sought; or (e) that the Interconnection Customer has filed applications for required permits to site on federal or state property.

Stand Alone Network Upgrades shall mean Network Upgrades that an Interconnection Customer may construct without affecting day-to-day operations of the New England Transmission System during their construction. The System Operator, Interconnection Customer, Interconnecting Transmission Owner, and any Affected Party as deemed appropriate by System Operator in accordance with applicable codes of conduct and confidentiality requirements, must agree as to what constitutes Stand Alone Network Upgrades and identify them in Appendix A to the Standard Large Generator Interconnection Agreement.

Standard Large Generator Interconnection Agreement (“LGIA”) shall mean the form of interconnection agreement applicable to an Interconnection Request pertaining to a Large Generating Facility, that is included in this Schedule 22 to the Tariff.

Standard Large Generator Interconnection Procedures (“LGIP”) shall mean the interconnection procedures applicable to an Interconnection Request pertaining to a Large Generating Facility that are included in this Schedule 22 to the Tariff.

System Operator shall mean ISO New England Inc. or a successor organization.

System Protection Facilities shall mean the equipment, including necessary signal protection communications equipment, required to protect (1) the New England Transmission System from faults or other electrical disturbances occurring at the Generating Facility and (2) the Generating Facility from faults or other electrical system disturbances occurring on the New England Transmission System or on other delivery systems or other generating systems to which the New England Transmission System is directly connected.

Trial Operation shall mean the period during which Interconnection Customer is engaged in on-site test operations and commissioning of the Generating Facility prior to Commercial Operation.

ARTICLE 2. EFFECTIVE DATE, TERM AND TERMINATION

- 2.1 Effective Date.** This LGIA shall become effective upon execution by the Parties subject to acceptance by the Commission (if applicable), or if filed unexecuted, upon the date specified by the Commission. System Operator and Interconnecting Transmission Owner, shall promptly and jointly file this LGIA with the Commission upon execution in accordance with Section 11.3 of the LGIP and Article 3.1, if required.
- 2.2 Term of Agreement.** This LGIA, subject to the provisions of Article 2.3, and by mutual agreement of the Parties, shall remain in effect for a period of 30 years from the Effective Date and shall be automatically renewed for each successive one-year period thereafter.
- 2.3 Termination Procedures.**
- 2.3.1 Written Notice.** This LGIA may be terminated by the Interconnection Customer, subject to continuing obligations of this LGIA and the Tariff, after giving the System Operator and Interconnecting Transmission Owner ninety (90) Calendar Days advance written notice, or by System Operator or Interconnecting Transmission Owner notifying the Commission after a Generating Facility retires pursuant to the Tariff, provided that if an Interconnection Customer exercises its right to terminate on ninety (90) Calendar Days, any reconnection would be treated as a new interconnection request; or this LGIA may be terminated by

Interconnecting Transmission Owner or System Operator by notifying the Commission after the Generating Facility permanently ceases Commercial Operation.

2.3.2 Default. Each Party may terminate this LGIA in accordance with Article 17.

Notwithstanding Articles 2.3.1 and 2.3.2, no termination shall become effective until the Parties have complied with all Applicable Laws and Regulations applicable to such termination, including the filing, if applicable, with the Commission of a notice of termination of this LGIA, which notice has been accepted for filing by the Commission. Termination of the LGIA shall not supersede or alter any requirements for deactivation or retirement of a generating unit under ISO New England Operating Documents, Applicable Reliability Standards, or successor documents.

2.4 Termination Costs. If a Party elects to terminate this Agreement pursuant to Article 2.3 above, each Party shall pay all costs incurred (including any cancellation costs relating to orders or contracts for Interconnection Facilities and equipment) or charges assessed by the other Party(ies), as of the date of such Party's(ies') receipt of such notice of termination, that are the responsibility of such Party(ies) under this LGIA. In the event of termination by a Party, all Parties shall use commercially Reasonable Efforts to mitigate the costs, damages and charges arising as a consequence of termination. Upon termination of this LGIA, unless otherwise ordered or approved by the Commission:

2.4.1 With respect to any portion of the Interconnecting Transmission Owner's Interconnection Facilities, Network Upgrades, or Distribution Upgrades to the extent covered by this agreement, that have not yet been constructed or installed, the Interconnecting Transmission Owner shall to the extent possible and with Interconnection Customer's authorization cancel any pending orders of, or return, any materials or equipment for, or contracts for construction of, such facilities; provided that in the event Interconnection Customer elects not to authorize such cancellation, Interconnection Customer shall assume all payment obligations with respect to such materials, equipment, and contracts, and the Interconnecting Transmission Owner shall deliver such material and equipment, and, if necessary, and to the extent possible, assign such contracts, to Interconnection Customer as soon as practicable, at Interconnection Customer's expense. To the extent that Interconnection Customer has already paid Interconnecting Transmission Owner for any or all such costs of materials or equipment not taken by Interconnection Customer, either (i) in the case of overpayment, Interconnecting Transmission

Owner shall promptly refund such amounts to Interconnection Customer, less any costs, including penalties incurred by the Interconnecting Transmission Owner to cancel any pending orders of or return such materials, equipment, or contracts, or (ii) in the case of underpayment, Interconnection Customer shall promptly pay such amounts still due plus any costs, including penalties incurred by Interconnecting Transmission Owner to cancel any pending orders of or return such materials, equipment, or contracts.

If an Interconnection Customer terminates this LGIA, it shall be responsible for all costs incurred in association with that Interconnection Customer's interconnection, including any cancellation costs relating to orders or contracts for Interconnection Facilities and equipment, and other expenses including any Network Upgrades for which the Interconnecting Transmission Owner has incurred expenses and has not been reimbursed by the Interconnection Customer.

2.4.2 Interconnecting Transmission Owner may, at its option, retain any portion of such materials, equipment, or facilities that Interconnection Customer chooses not to accept delivery of, in which case Interconnecting Transmission Owner shall be responsible for all costs associated with procuring such materials, equipment, or facilities.

2.4.3 With respect to any portion of the Interconnection Facilities, and any other facilities already installed or constructed pursuant to the terms of this LGIA, Interconnection Customer shall be responsible for all costs associated with the removal, relocation or other disposition or retirement of such materials, equipment, or facilities.

2.5 Disconnection. Upon termination of this LGIA, Interconnection Service shall terminate and, the Parties will take all appropriate steps to disconnect the Large Generating Facility from the Interconnecting Transmission Owner's Interconnection Facilities. All costs required to effectuate such disconnection shall be borne by the terminating Party, unless such termination resulted from a non-terminating Party's Default of this LGIA or such non-terminating Party otherwise is responsible for these costs under this LGIA.

2.6 Survival. This LGIA shall continue in effect after termination to the extent necessary to provide for final billings and payments and for costs incurred hereunder, including billings and payments pursuant to this LGIA; to permit the determination and enforcement of liability and indemnification obligations arising from acts or events that

occurred while this LGIA was in effect; and to permit each Party to have access to the lands of the other Party(ies) pursuant to this LGIA or other applicable agreements, to disconnect, remove or salvage its own facilities and equipment.

ARTICLE 3. REGULATORY FILINGS

- 3.1 Filing.** The System Operator and Interconnecting Transmission Owner shall jointly file this LGIA (and any amendment hereto) with the appropriate Governmental Authority, if required, in accordance with Section 11.3 of the LGIP. Interconnection Customer may request that any information so provided be subject to the confidentiality provisions of Article 22. If the Interconnection Customer has executed this LGIA, or any amendment thereto, the Interconnection Customer shall reasonably cooperate with the System Operator and Interconnecting Transmission Owner with respect to such filing and to provide any information reasonably requested by the System Operator and/or the Interconnecting Transmission Owner needed to comply with applicable regulatory requirements.

ARTICLE 4. SCOPE OF SERVICE

- 4.1 Interconnection Product Options.** Interconnection Customer has selected the following (checked) type(s) of Interconnection Service:

Check: ___ NR for NR Interconnection Service (NR Capability Only)

X CNR for CNR Interconnection Service (CNR Capability and NR Capability)

- 4.1.1 Capacity Network Resource Interconnection Service (CNR Interconnection Service).**

4.1.1.1 The Product. The System Operator and Interconnecting Transmission Owner must conduct the necessary studies and the Interconnecting Transmission Owner and Affected Parties must construct the Network Upgrades needed to interconnect the Large Generating Facility in a manner comparable to that in which all other Capacity Network Resources are interconnected under the CNR Interconnection Standard. CNR Interconnection Service allows the Interconnection Customer's Large Generating Facility to be designated as a Capacity Network Resource, to

participate in the New England Markets, in accordance with Market Rule 1, Section III of the Tariff, up to the net CNR Capability, or as otherwise provided in Market Rule 1, Section III of the Tariff, on the same basis as all other existing Capacity Network Resources, and to be studied as a Capacity Network Resource on the assumption that such a designation will occur.

4.1.2 Network Resource Interconnection Service (NR Interconnection Service).

4.1.2.1 The Product. The System Operator and Interconnecting Transmission Owner must conduct the necessary studies and Interconnecting Transmission Owner and Affected Parties must construct the Network Upgrades needed to interconnect the Large Generating Facility in a manner comparable to that in which all other Network Resources are interconnected under the NC Interconnection Standard.

NC Interconnection Service allows the Interconnection Customer's Large Generating Facility to participate in the New England Markets, in accordance with Market Rule 1, Section III of the Tariff, up to the gross and net NR Capability or as otherwise provided in Market Rule 1, Section III of the Tariff. Notwithstanding the above, the portion of a Large Generating Facility that has been designated as a Network Resource interconnected under the NC Interconnection Standard cannot be a capacity resource under Section III.13 of the Tariff, unless pursuant to a new Interconnection Request for CNR Interconnection Service.

4.2 Provision of Service. System Operator and Interconnecting Transmission Owner shall provide Interconnection Service for the Large Generating Facility at the Point of Interconnection.

4.3 Performance Standards. Each Party shall perform all of its obligations under this LGIA in accordance with Applicable Laws and Regulations, the ISO New England Operating Documents, Applicable Reliability Standards, or successor documents, and Good Utility Practice, and to the extent a Party is required or prevented or limited in taking any action by such requirements and standards, such Party shall not be deemed to be in Breach of this LGIA for its compliance therewith. If such Party is the Interconnecting Transmission Owner, then that Party shall amend the LGIA and System Operator, in conjunction with

the Interconnecting Transmission Owner, shall submit the amendment to the Commission for approval.

4.4 No Transmission Delivery Service. The execution of this LGIA does not constitute a request for, nor the provision of, any service except for Interconnection Service, including, but not limited to, transmission delivery service, local delivery service, distribution service, capacity service, energy service, or Ancillary Services under any applicable tariff, and does not convey any right to deliver electricity to any specific customer or Point of Delivery.

4.5 Transmission Delivery Service Implications. CNR Interconnection Service and NR Interconnection Service allow the Interconnection Customer's Large Generating Facility to be designated by any Network Customer under the Tariff on the New England Transmission System as a Capacity Network Resource or Network Resource, up to the net CNR Capability or NR Capability, respectively, on the same basis as all other existing Capacity Network Resources and Network Resources interconnected to the New England Transmission System, and to be studied as a Capacity Network Resource or a Network Resource on the assumption that such a designation will occur. Although CNR Interconnection Service and NR Interconnection Service do not convey a reservation of transmission service, any Network Customer can utilize its network service under the Tariff to obtain delivery of capability from the Interconnection Customer's Large Generating Facility in the same manner as it accesses Capacity Network Resources and Network Resources. A Large Generating Facility receiving CNR Interconnection Service or NR Interconnection Service may also be used to provide Ancillary Services, in accordance with the Tariff and Market Rule 1, after technical studies and/or periodic analyses are performed with respect to the Large Generating Facility's ability to provide any applicable Ancillary Services, provided that such studies and analyses have been or would be required in connection with the provision of such Ancillary Services by any existing Capacity Network Resource or Network Resource. However, if an Interconnection Customer's Large Generating Facility has not been designated as a Capacity Network Resource or as a Network Resource by any load, it cannot be required to provide Ancillary Services except to the extent such requirements extend to all Generating Facilities that are similarly situated.

CNR Interconnection Service and NR Interconnection Service do not necessarily provide the Interconnection Customer with the capability to physically deliver the output of its Large Generating Facility to any particular load on the New England Transmission System without incurring congestion costs. In the event of

transmission constraints on the New England Transmission System, the Interconnection Customer's Large Generating Facility shall be subject to the applicable congestion management procedures for the New England Transmission System in the same manner as other Capacity Network Resources or Network Resources.

There is no requirement either at the time of study or interconnection, or at any point in the future, that the Interconnection Customer's Large Generating Facility be designated as a Capacity Network Resource or as a Network Resource by a Network Service Customer under the Tariff or that the Interconnection Customer identify a specific buyer (or sink). To the extent a Network Customer does designate the Large Generating Facility as either a Capacity Network Resource or a Network Resource, it must do so pursuant to the Tariff.

Once an Interconnection Customer satisfies the requirements for obtaining CNR Interconnection Service or NR Interconnection Service, as long as the Large Generating Facility has not been deemed to be retired, any future transmission service request for delivery from the Large Generating Facility on the New England Transmission System of any amount of capacity capability and/or energy capability will not require that any additional studies be performed or that any further upgrades associated with such Large Generating Facility be undertaken, regardless of whether or not such Large Generating Facility is ever designated by a Network Customer as a Capacity Network Resource or Network Resource, and regardless of changes in ownership of the Large Generating Facility. To the extent the Interconnection Customer enters into an arrangement for long-term transmission service for deliveries from the Large Generating Facility outside the New England Transmission System, or if the unit has been deemed to be retired, such request may require additional studies and upgrades in order for Interconnecting Transmission Owner to grant such request.

- 4.6 Interconnection Customer Provided Services.** The services provided by Interconnection Customer under this LGIA are set forth in Article 9.6 and Article 13.4. Interconnection Customer shall be paid for such services in accordance with Article 11.6.

ARTICLE 5. INTERCONNECTION FACILITIES ENGINEERING, PROCUREMENT, AND CONSTRUCTION

5.1 Options. Unless otherwise mutually agreed to between the Parties, Interconnection Customer shall specify the In-Service Date, Initial Synchronization Date, and Commercial Operation Date as specified in the Interconnection Request or as subsequently revised pursuant to Section 4.4 of the LGIP; and select either Standard Option or Alternate Option set forth below for completion of the Interconnecting Transmission Owner's Interconnection Facilities and Network Upgrades as set forth in Appendix A, and such dates and selected option shall be set forth in Appendix B (Milestones). In accordance with Section 8 of the LGIP and unless otherwise mutually agreed, the Alternate Option is not an available option if the Interconnection Customer waived the Interconnection Facilities Study.

5.1.1 Standard Option. The Interconnecting Transmission Owner shall design, procure, and construct the Interconnecting Transmission Owner's Interconnection Facilities and Network Upgrades, using Reasonable Efforts to complete the Interconnecting Transmission Owner's Interconnection Facilities and Network Upgrades by the dates set forth in Appendix B (Milestones). The Interconnecting Transmission Owner shall not be required to undertake any action which is inconsistent with its standard safety practices, its material and equipment specifications, its design criteria and construction procedures, its labor agreements, and Applicable Laws and Regulations. In the event the Interconnecting Transmission Owner reasonably expects that it will not be able to complete the Interconnecting Transmission Owner's Interconnection Facilities and Network Upgrades by the specified dates, the Interconnecting Transmission Owner shall promptly provide written notice to the Interconnection Customer and shall undertake Reasonable Efforts to meet the earliest dates thereafter.

5.1.2 Alternate Option. If the dates designated by Interconnection Customer are acceptable to Interconnecting Transmission Owner, the Interconnecting Transmission Owner shall so notify Interconnection Customer within thirty (30) Calendar Days, and shall assume responsibility for the design, procurement and construction of the Interconnecting Transmission Owner's Interconnection Facilities by the designated dates.

If Interconnecting Transmission Owner subsequently fails to complete Interconnecting Transmission Owner's Interconnection Facilities by the In-

Service Date, to the extent necessary to provide back feed power; or fails to complete Network Upgrades by the Initial Synchronization Date to the extent necessary to allow for Trial Operation at full power output, unless other arrangements are made by the Parties for such Trial Operation; or fails to complete the Network Upgrades by the Commercial Operation Date, as such dates are reflected in Appendix B (Milestones); Interconnecting Transmission Owner shall pay Interconnection Customer liquidated damages in accordance with Article 5.3, Liquidated Damages, provided, however, the dates designated by Interconnection Customer shall be extended day for day for each day that the applicable System Operator refuses to grant clearances to install equipment.

- 5.1.3 Option to Build.** If the dates designated by Interconnection Customer are not acceptable to Interconnecting Transmission Owner, the Interconnecting Transmission Owner shall so notify the Interconnection Customer within thirty (30) Calendar Days, and unless the Parties agree otherwise, Interconnection Customer shall have the option to assume responsibility for the design, procurement and construction of Interconnecting Transmission Owner's Interconnection Facilities and Stand Alone Network Upgrades on the dates specified in Article 5.1.2. The System Operator, Interconnecting Transmission Owner, Interconnection Customer, and any Affected Party as deemed appropriate by System Operator in accordance with applicable codes of conduct and confidentiality requirements must agree as to what constitutes Stand Alone Network Upgrades and identify such Stand Alone Network Upgrades in Appendix A to the LGIA. Except for Stand Alone Network Upgrades, Interconnection Customer shall have no right to construct Network Upgrades under this option.
- 5.1.4 Negotiated Option.** If the Interconnection Customer elects not to exercise its option under Article 5.1.3 (Option to Build), Interconnection Customer shall so notify Interconnecting Transmission Owner within thirty (30) Calendar Days, and the Parties shall in good faith attempt to negotiate terms and conditions (including revision of the specified dates and liquidated damages, the provision of incentives or the procurement and construction of a portion of the Interconnecting Transmission Owner's Interconnection Facilities and Stand Alone Network Upgrades by Interconnection Customer) pursuant to which Interconnecting Transmission Owner is responsible for the design, procurement and construction of the Interconnecting Transmission Owner's Interconnection Facilities and Network Upgrades. If the Parties are unable to reach agreement on such terms and conditions, Interconnecting Transmission Owner shall assume responsibility

for the design, procurement and construction of the Interconnecting Transmission Owner's Interconnection Facilities and Network Upgrades pursuant to 5.1.1 (Standard Option).

5.2 General Conditions Applicable to Option to Build. If Interconnection Customer assumes responsibility for the design, procurement and construction of the Interconnecting Transmission Owner's Interconnection Facilities and Stand Alone Network Upgrades,

- (1) the Interconnection Customer shall engineer, procure equipment, and construct the Interconnecting Transmission Owner's Interconnection Facilities and Stand Alone Network Upgrades (or portions thereof) using Good Utility Practice and using standards and specifications provided in advance by the Interconnecting Transmission Owner;
- (2) Interconnection Customer's engineering, procurement and construction of the Interconnecting Transmission Owner's Interconnection Facilities and Stand Alone Network Upgrades shall comply with all requirements of law to which Interconnecting Transmission Owner would be subject in the engineering, procurement or construction of the Interconnecting Transmission Owner's Interconnection Facilities and Stand Alone Network Upgrades;
- (3) Interconnecting Transmission Owner shall review and approve the engineering design, equipment acceptance tests, and the construction of the Interconnecting Transmission Owner's Interconnection Facilities and Stand Alone Network Upgrades;
- (4) prior to commencement of construction, Interconnection Customer shall provide to Interconnecting Transmission Owner a schedule for construction of the Interconnecting Transmission Owner's Interconnection Facilities and Stand Alone Network Upgrades, and shall promptly respond to requests for information from Interconnecting Transmission Owner;
- (5) at any time during construction, Interconnecting Transmission Owner shall have the right to gain unrestricted access to the Interconnecting Transmission Owner's Interconnection Facilities and Stand Alone Network Upgrades and to conduct inspections of the same;
- (6) at any time during construction, should any phase of the engineering, equipment procurement, or construction of the Interconnecting Transmission Owner's Interconnection Facilities and Stand Alone Network Upgrades not meet the standards and

specifications provided by Interconnecting Transmission Owner, the Interconnection Customer shall be obligated to remedy deficiencies in that portion of the Interconnecting Transmission Owner's Interconnection Facilities and Stand Alone Network Upgrades;

(7) the Interconnection Customer shall indemnify the Interconnecting Transmission Owner for claims arising from the Interconnection Customer's construction of Interconnecting Transmission Owner's Interconnection Facilities and Stand Alone Network Upgrades under the terms and procedures applicable to Article 18.1 (Indemnity);

(8) the Interconnection Customer shall transfer control of Interconnecting Transmission Owner's Interconnection Facilities and Stand Alone Network Upgrades to the Interconnecting Transmission Owner;

(9) Unless Parties otherwise agree, Interconnection Customer shall transfer ownership of Interconnecting Transmission Owner's Interconnection Facilities and Stand-Alone Network Upgrades to Interconnecting Transmission Owner;

(10) Interconnecting Transmission Owner shall approve and accept for operation and maintenance the Interconnecting Transmission Owner's Interconnection Facilities and Stand Alone Network Upgrades to the extent engineered, procured, and constructed in accordance with this Article 5.2; and

(11) Interconnection Customer shall deliver to Interconnecting Transmission Owner "as built" drawings, information, and any other documents that are reasonably required by Interconnecting Transmission Owner to assure that the Interconnection Facilities and Stand-Alone Network Upgrades are built to the standards and specifications required by Interconnecting Transmission Owner.

5.3 Liquidated Damages. The actual damages to the Interconnection Customer, in the event the Interconnecting Transmission Owner's Interconnection Facilities or Network Upgrades are not completed by the dates designated by the Interconnection Customer and accepted by the Interconnecting Transmission Owner pursuant to subparagraphs 5.1.2 or 5.1.4, above, may include Interconnection Customer's fixed operation and maintenance costs and lost opportunity costs. Such actual damages are uncertain and impossible to determine at this time. Because of such uncertainty, any liquidated damages paid by the Interconnecting Transmission Owner to the Interconnection Customer in the event that Interconnecting Transmission Owner does not complete any portion of the

Interconnecting Transmission Owner's Interconnection Facilities or Network Upgrades by the applicable dates, shall be an amount equal to $\frac{1}{2}$ of 1 percent per day of the actual cost of the Interconnecting Transmission Owner's Interconnection Facilities and Network Upgrades, in the aggregate, for which Interconnecting Transmission Owner has assumed responsibility to design, procure and construct.

However, in no event shall the total liquidated damages exceed 20 percent of the actual cost of the Interconnecting Transmission Owner's Interconnection Facilities and Network Upgrades for which the Interconnecting Transmission Owner has assumed responsibility to design, procure, and construct. The foregoing payments will be made by the Interconnecting Transmission Owner to the Interconnection Customer as just compensation for the damages caused to the Interconnection Customer, which actual damages are uncertain and impossible to determine at this time, and as reasonable liquidated damages, but not as a penalty or a method to secure performance of this LGIA. Liquidated damages, when the Parties agree to them, are the exclusive remedy for the Interconnecting Transmission Owner's failure to meet its schedule.

No liquidated damages shall be paid to Interconnection Customer if: (1) Interconnection Customer is not ready to commence use of the Interconnecting Transmission Owner's Interconnection Facilities or Network Upgrades to take the delivery of power for the Large Generating Facility's Trial Operation or to export power from the Large Generating Facility on the specified dates, unless the Interconnection Customer would have been able to commence use of the Interconnecting Transmission Owner's Interconnection Facilities or Network Upgrades to take the delivery of power for Large Generating Facility's Trial Operation or to export power from the Large Generating Facility, but for Interconnecting Transmission Owner's delay; (2) the Interconnecting Transmission Owner's failure to meet the specified dates is the result of the action or inaction of the Interconnection Customer or any other Interconnection Customer who has entered into an LGIA with the Interconnecting Transmission Owner or any cause beyond Interconnecting Transmission Owner's reasonable control or reasonable ability to cure, including, but not limited to, actions by the System Operator that cause delays and/or delays in licensing, permitting or consents where the Interconnecting Transmission Owner has pursued such licenses, permits or consents in good faith; (3) the Interconnection Customer has assumed responsibility for the design, procurement and construction of the Interconnecting Transmission Owner's Interconnection Facilities and Stand Alone Network Upgrades; or (4) the Parties have otherwise agreed.

- 5.4 Power System Stabilizers.** If a Power System Stabilizer is required to be installed on the Large Generating Facility for the purpose of maintaining system stability, the Interconnection Customer shall procure, install, maintain and operate Power System Stabilizers in accordance with the guidelines and procedures established by the System Operator and Interconnecting Transmission Owner, and consistent with the ISO New England Operating Documents, Applicable Reliability Standards, or successor documents. The System Operator and Interconnecting Transmission Owner reserve the right to reasonably establish minimum acceptable settings for any installed Power System Stabilizers, subject to the design and operating limitations of the Large Generating Facility. If the Large Generating Facility's Power System Stabilizers are removed from service or not capable of automatic operation, the Interconnection Customer shall immediately notify the System Operator and Interconnecting Transmission Owner, or their designated representative. The requirements of this paragraph shall not apply to non-synchronous power production equipment.
- 5.5 Equipment Procurement.** If responsibility for construction of the Interconnecting Transmission Owner's Interconnection Facilities or Network Upgrades is to be borne by the Interconnecting Transmission Owner, then the Interconnecting Transmission Owner shall commence design of the Interconnecting Transmission Owner's Interconnection Facilities or Network Upgrades and procure necessary equipment as soon as practicable after all of the following conditions are satisfied, unless the Parties otherwise agree in writing:
- 5.5.1** The Interconnecting Transmission Owner has completed the Facilities Study pursuant to the Facilities Study Agreement;
 - 5.5.2** The Interconnecting Transmission Owner has received written authorization to proceed with design and procurement from the Interconnection Customer by the date specified in Appendix B (Milestones); and
 - 5.5.3** The Interconnection Customer has provided security to the Interconnecting Transmission Owner in accordance with Article 11.5 by the dates specified in Appendix B (Milestones).
- 5.6 Construction Commencement.** The Interconnecting Transmission Owner shall commence construction of the Interconnecting Transmission Owner's Interconnection

Facilities and Network Upgrades for which it is responsible as soon as practicable after the following additional conditions are satisfied:

- 5.6.1** Approval of the appropriate Governmental Authority has been obtained for any facilities requiring regulatory approval;
 - 5.6.2** Necessary real property rights and rights-of-way have been obtained, to the extent required for the construction of a discrete aspect of the Interconnecting Transmission Owner's Interconnection Facilities and Network Upgrades;
 - 5.6.3** The Interconnecting Transmission Owner has received written authorization to proceed with construction from the Interconnection Customer by the date specified in Appendix B (Milestones); and
 - 5.6.4** The Interconnection Customer has provided security to Interconnecting Transmission Owner in accordance with Article 11.5 by the dates specified in Appendix B (Milestones).
- 5.7 Work Progress.** The Interconnection Customer and the Interconnecting Transmission Owner shall keep each Party informed, by written quarterly progress reports, as to the progress of their respective design, procurement and construction efforts in order to meet the dates specified in Appendix B (Milestones). Any Party may also, at any other time, request a written progress report from the other Parties. If, at any time, the Interconnection Customer determines that the completion of the Interconnecting Transmission Owner's Interconnection Facilities will not be required until after the specified In-Service Date, the Interconnection Customer, upon the System Operator's approval that the change in the In-Service Date will not constitute a Material Modification pursuant to Section 4.4 of the LGIP, will provide written notice to the Interconnecting Transmission Owner of such later date upon which the completion of the Interconnecting Transmission Owner's Interconnection Facilities will be required.
- 5.8 Information Exchange.** As soon as reasonably practicable after the Effective Date, the Parties shall exchange information regarding the design and compatibility of the Parties' Interconnection Facilities and compatibility of the Interconnection Facilities with the New England Transmission System, and shall work diligently and in good faith to make any necessary design changes.

- 5.9 Limited Operation.** If any of the Interconnecting Transmission Owner’s Interconnection Facilities or Network Upgrades are not reasonably expected to be completed prior to the Commercial Operation Date of the Large Generating Facility, System Operator and the Interconnecting Transmission Owner shall, upon the request and at the expense of Interconnection Customer, perform operating studies on a timely basis to determine the extent to which the Large Generating Facility and the Interconnection Customer’s Interconnection Facilities may operate prior to the completion of the Interconnecting Transmission Owner’s Interconnection Facilities or Network Upgrades consistent with Applicable Laws and Regulations, Applicable Reliability Standards, Good Utility Practice, and this LGIA. System Operator and Interconnecting Transmission Owner shall permit Interconnection Customer to operate the Large Generating Facility and the Interconnection Customer Interconnection Facilities in accordance with the results of such studies.
- 5.10 Interconnection Customer’s Interconnection Facilities (“ICIF”).** Interconnection Customer shall, at its expense, design, procure, construct, own and install the ICIF, as set forth in Appendix A (Interconnection Facilities, Network Upgrades and Distribution Upgrades).
- 5.10.1 Large Generating Facility Specifications.** Interconnection Customer shall submit initial specifications for the ICIF, including System Protection Facilities, to Interconnecting Transmission Owner at least one hundred eighty (180) Calendar Days prior to the Initial Synchronization Date; and final specifications for review and comment at least ninety (90) Calendar Days prior to the Initial Synchronization Date. Interconnecting Transmission Owner shall review such specifications to ensure that the ICIF are compatible with the technical specifications, operational control, and safety requirements of the Interconnecting Transmission Owner and comment on such specifications within thirty (30) Calendar Days of Interconnection Customer’s submission. All specifications provided hereunder shall be deemed confidential.
- 5.10.2 Interconnecting Transmission Owner’s Review.** Interconnecting Transmission Owner’s review of Interconnection Customer’s final specifications shall not be construed as confirming, endorsing, or providing a warranty as to the design, fitness, safety, durability or reliability of the Large Generating Facility, or the ICIF. Interconnection Customer shall make such changes to the ICIF as may reasonably be required by Interconnecting Transmission Owner, in accordance with Good Utility Practice, to ensure that the ICIF are compatible with the

technical specifications, operational control, and safety requirements of the Interconnecting Transmission Owner.

5.10.3 ICIF Construction. The ICIF shall be designed and constructed in accordance with Good Utility Practice. Within one hundred twenty (120) Calendar Days after the Commercial Operation Date, unless the Parties agree on another mutually acceptable deadline, the Interconnection Customer shall deliver to the Interconnecting Transmission Owner “as-built” drawings, information and documents for the ICIF, such as: a one-line diagram, a site plan showing the Large Generating Facility and the ICIF, plan and elevation drawings showing the layout of the ICIF, a relay functional diagram, relaying AC and DC schematic wiring diagrams and relay settings for all facilities associated with the Interconnection Customer’s step-up transformers, the facilities connecting the Large Generating Facility to the step-up transformers and the ICIF, and the impedances (determined by factory tests) for the associated step-up transformers and the Large Generating Facilities. The Interconnection Customer shall provide Interconnecting Transmission Owner specifications for the excitation system, automatic voltage regulator, Large Generating Facility control and protection settings, transformer tap settings, and communications, if applicable.

5.11 Interconnecting Transmission Owner’s Interconnection Facilities Construction. The Interconnecting Transmission Owner’s Interconnection Facilities shall be designed and constructed in accordance with Good Utility Practice. Upon request, within one hundred twenty (120) Calendar Days after the Commercial Operation Date, unless the Parties agree on another mutually acceptable deadline, the Interconnecting Transmission Owner shall deliver to the Interconnection Customer the following “as-built” drawings, information and documents for the Interconnecting Transmission Owner’s Interconnection Facilities. The appropriate drawings and relay diagrams shall be included in Appendix A of the LGIA.

The System Operator will obtain operational control of the Interconnecting Transmission Owner’s Interconnection Facilities and Stand Alone Network Upgrades upon completion of such facilities pursuant to the TOA.

5.12 Access Rights. Upon reasonable notice and supervision by a Party, and subject to any required or necessary regulatory approvals, a Party (“Granting Party”) shall furnish at the incremental cost to another Party (“Access Party”) any rights of use, licenses, rights of

way and easements with respect to lands owned or controlled by the Granting Party, its agents if allowed under the applicable agency agreement, that are necessary to enable the Access Party solely to obtain ingress and egress to construct, operate, maintain, repair, test (or witness testing), inspect, replace or remove facilities and equipment to: (i) interconnect the Large Generating Facility with the Administered Transmission System; (ii) operate and maintain the Large Generating Facility, the Interconnection Facilities and the New England Transmission System; and (iii) disconnect or remove the Access Party's facilities and equipment upon termination of this LGIA. In exercising such licenses, rights of way and easements, the Access Party shall not unreasonably disrupt or interfere with normal operation of the Granting Party's business and shall adhere to the safety rules and procedures established in advance, as may be changed from time to time, by the Granting Party and provided to the Access Party.

- 5.13 Lands of Other Property Owners.** If any part of the Interconnecting Transmission Owner's Interconnection Facilities and/or Network Upgrades is to be installed on property owned by persons other than Interconnection Customer or Interconnecting Transmission Owner, the Interconnecting Transmission Owner shall at Interconnection Customer's expense use Reasonable Efforts, including use of its eminent domain authority, and to the extent consistent with state law, to procure from such persons any rights of use, licenses, rights of way and easements that are necessary to construct, operate, maintain, test, inspect, replace or remove the Interconnecting Transmission Owner's Interconnection Facilities and/or Network Upgrades upon such property. Notwithstanding the foregoing, the Interconnecting Transmission Owner shall not be obligated to exercise eminent domain authority in a manner inconsistent with Applicable Laws and Regulations or when an Interconnection Customer is authorized under Applicable Laws and Regulations to exercise eminent domain on its own behalf.
- 5.14 Permits.** System Operator, Interconnecting Transmission Owner and Interconnection Customer shall cooperate with each other in good faith in obtaining all permits, licenses, and authorizations that are necessary to accomplish the interconnection in compliance with Applicable Laws and Regulations. With respect to this paragraph, Interconnecting Transmission Owner shall provide permitting assistance to the Interconnection Customer comparable to that provided to the Interconnecting Transmission Owner's own, or an Affiliate's generation.
- 5.15 Early Construction of Base Case Facilities.** Interconnection Customer may request Interconnecting Transmission Owner to construct, and Interconnecting Transmission Owner shall construct, using Reasonable Efforts to accommodate Interconnection

Customer's In-Service Date, all or any portion of any Network Upgrades required for Interconnection Customer to be interconnected to the Administered Transmission System, which are included in the Base Case of the Facilities Study for the Interconnection Customer, and which also are required to be constructed for another Interconnection Customer, but where such construction is not scheduled to be completed in time to achieve Interconnection Customer's In-Service Date. The Interconnection Customer shall reimburse the Interconnecting Transmission Owner for all costs incurred related to early construction to the extent such costs are not recovered from other Interconnection Customers included in the base case.

- 5.16 Suspension.** Interconnection Customer reserves the right, upon written notice to Interconnecting Transmission Owner and System Operator, to suspend at any time all work by Interconnecting Transmission Owner associated with the construction and installation of Interconnecting Transmission Owner's Interconnection Facilities and/or Network Upgrades required under this LGIA with the condition that the New England Transmission System shall be left in a safe and reliable condition in accordance with Good Utility Practice and the System Operator's and Interconnecting Transmission Owner's safety and reliability criteria. In such event, Interconnection Customer shall be responsible for all reasonable and necessary costs which Interconnecting Transmission Owner (i) has incurred pursuant to this LGIA prior to the suspension and (ii) incurs in suspending such work, including any costs incurred to perform such work as may be necessary to ensure the safety of persons and property and the integrity of the New England Transmission System during such suspension and, if applicable, any costs incurred in connection with the cancellation or suspension of material, equipment and labor contracts which Interconnecting Transmission Owner cannot reasonably avoid; provided, however, that prior to canceling or suspending any such material, equipment or labor contract, Interconnecting Transmission Owner shall obtain Interconnection Customer's authorization to do so.

Interconnecting Transmission Owner shall invoice Interconnection Customer for such costs pursuant to Article 12 and shall use due diligence to minimize its costs. In the event Interconnection Customer suspends work by Interconnecting Transmission Owner required under this LGIA pursuant to this Article 5.16, and has not requested Interconnecting Transmission Owner to recommence the work required under this LGIA on or before the expiration of three (3) years following commencement of such suspension, this LGIA shall be deemed terminated. The three-year period shall begin on the date the suspension is requested, or the date of the written notice to Interconnecting Transmission Owner and System Operator, if no effective date is specified. The three-

year period shall in no way result in an extension of the In-Service Date, the Initial Synchronization Date or the Commercial Operation Date that exceeds seven (7) years from the date of the Interconnection Request; otherwise, this LGIA shall be deemed terminated.

5.17 Taxes.

5.17.1 Payments Not Taxable. The Parties intend that all payments or property transfers made by any Party for the installation of the Interconnecting Transmission Owner's Interconnection Facilities and the Network Upgrades shall be non-taxable, either as contributions to capital, or as an advance, in accordance with the Internal Revenue Code and any applicable state income tax laws and shall not be taxable as contributions in aid of construction or otherwise under the Internal Revenue Code and any applicable state income tax laws.

5.17.2 Representations and Covenants. In accordance with IRS Notice 2001-82 and IRS Notice 88-129, Interconnection Customer represents and covenants that (i) ownership of the electricity generated at the Large Generating Facility will pass to another party prior to the transmission of the electricity on the New England Transmission System, (ii) for income tax purposes, the amount of any payments and the cost of any property transferred to the Interconnecting Transmission Owner for the Interconnecting Transmission Owner's Interconnection Facilities will be capitalized by Interconnection Customer as an intangible asset and recovered using the straight-line method over a useful life of twenty (20) years, and (iii) any portion of the Interconnecting Transmission Owner's Interconnection Facilities that is a "dual-use intertie," within the meaning of IRS Notice 88-129, is reasonably expected to carry only a de minimis amount of electricity in the direction of the Large Generating Facility. For this purpose, "de minimis amount" means no more than 5 percent of the total power flows in both directions, calculated in accordance with the "5 percent test" set forth in IRS Notice 88-129. This is not intended to be an exclusive list of the relevant conditions that must be met to conform to IRS requirements for non-taxable treatment.

At Interconnecting Transmission Owner's request, Interconnection Customer shall provide Interconnecting Transmission Owner with a report from an independent engineer confirming its representation in clause (iii), above. Interconnecting Transmission Owner represents and covenants that the cost of the Interconnecting Transmission Owner's Interconnection Facilities paid for by

Interconnection Customer will have no net effect on the base upon which rates are determined.

5.17.3 Indemnification for the Cost Consequences of Current Tax Liability Imposed Upon Interconnecting Transmission Owner. Notwithstanding Article 5.17.1, Interconnection Customer shall protect, indemnify and hold harmless Interconnecting Transmission Owner from the cost consequences of any current tax liability imposed against Interconnecting Transmission Owner as the result of payments or property transfers made by Interconnection Customer to Interconnecting Transmission Owner under this LGIA, as well as any interest and penalties, other than interest and penalties attributable to any delay caused by Interconnecting Transmission Owner.

The Interconnecting Transmission Owner shall not include a gross-up for the cost consequences of any current tax liability in the amounts it charges Interconnection Customer under this LGIA unless (i) Interconnecting Transmission Owner has determined, in good faith, that the payments or property transfers made by Interconnection Customer to Interconnecting Transmission Owner should be reported as income subject to taxation or (ii) any Governmental Authority directs Interconnecting Transmission Owner to report payments or property as income subject to taxation; provided, however, that Interconnecting Transmission Owner may require Interconnection Customer to provide security, in a form reasonably acceptable to Interconnecting Transmission Owner (such as a parental guarantee or a letter of credit), in an amount equal to the cost consequences of any current tax liability under this Article 5.17. Interconnection Customer shall reimburse Interconnecting Transmission Owner for such costs on a fully grossed-up basis, in accordance with Article 5.17.4, within thirty (30) Calendar Days of receiving written notification from Interconnecting Transmission Owner of the amount due, including detail about how the amount was calculated.

The indemnification obligation shall terminate at the earlier of (1) the expiration of the ten year testing period, and the applicable statute of limitation, as it may be extended by the Interconnecting Transmission Owner upon request of the IRS, to keep these years open for audit or adjustment, or (2) the occurrence of a subsequent taxable event and the payment of any related indemnification obligations as contemplated by this Article 5.17.

5.17.4 Tax Gross-Up Amount. Interconnection Customer’s liability for the cost consequences of any current tax liability under this Article 5.17 shall be calculated on a fully grossed-up basis. Except as may otherwise be agreed to by the parties, this means that Interconnection Customer will pay Interconnecting Transmission Owner, in addition to the amount paid for the Interconnection Facilities and Network Upgrades, an amount equal to (1) the current taxes imposed on Interconnecting Transmission Owner (“Current Taxes”) on the excess of (a) the gross income realized by Interconnecting Transmission Owner as a result of payments or property transfers made by Interconnection Customer to Interconnecting Transmission Owner under this LGIA (without regard to any payments under this Article 5.17) (the “Gross Income Amount”) over (b) the present value of future tax deductions for depreciation that will be available as a result of such payments or property transfers (the “Present Value Depreciation Amount”), plus (2) an additional amount sufficient to permit the Interconnecting Transmission Owner to receive and retain, after the payment of all Current Taxes, an amount equal to the net amount described in clause (1). For this purpose, (i) Current Taxes shall be computed based on Interconnecting Transmission Owner composite federal and state tax rates at the time the payments or property transfers are received and Interconnecting Transmission Owner will be treated as being subject to tax at the highest marginal rates in effect at that time (the “Current Tax Rate”), and (ii) the Present Value Depreciation Amount shall be computed by discounting Interconnecting Transmission Owner’s anticipated tax depreciation deductions as a result of such payments or property transfers by Interconnecting Transmission Owner current weighted average cost of capital. Thus, the formula for calculating Interconnection Customer’s liability to Transmission Owner pursuant to this Article 5.17.4 can be expressed as follows: $(\text{Current Tax Rate} \times (\text{Gross Income Amount} - \text{Present Value of Tax Depreciation})) / (1 - \text{Current Tax Rate})$. Interconnection Customer’s estimated tax liability in the event taxes are imposed shall be stated in Appendix A (Interconnection Facilities, Network Upgrades and Distribution Upgrades).

5.17.5 Private Letter Ruling or Change or Clarification of Law. At Interconnection Customer’s request and expense, Interconnecting Transmission Owner shall file with the IRS a request for a private letter ruling as to whether any property transferred or sums paid, or to be paid, by Interconnection Customer to Interconnecting Transmission Owner under this LGIA are subject to federal income taxation. Interconnection Customer will prepare the initial draft of the request for a private letter ruling, and will certify under penalties of perjury that

all facts represented in such request are true and accurate to the best of Interconnection Customer's knowledge. Interconnecting Transmission Owner and Interconnection Customer shall cooperate in good faith with respect to the submission of such request.

Interconnecting Transmission Owner shall keep Interconnection Customer fully informed of the status of such request for a private letter ruling and shall execute either a privacy act waiver or a limited power of attorney, in a form acceptable to the IRS, that authorizes Interconnection Customer to participate in all discussions with the IRS regarding such request for a private letter ruling. Interconnecting Transmission Owner shall allow Interconnection Customer to attend all meetings with IRS officials about the request and shall permit Interconnection Customer to prepare the initial drafts of any follow-up letters in connection with the request.

5.17.6 Subsequent Taxable Events. If, within ten (10) years from the date on which the relevant Interconnecting Transmission Owner's Interconnection Facilities are placed in service, (i) Interconnection Customer Breaches the covenant contained in Article 5.17.2, (ii) a "disqualification event" occurs within the meaning of IRS Notice 88-129, or (iii) this LGIA terminates and Interconnecting Transmission Owner retains ownership of the Interconnection Facilities and Network Upgrades, the Interconnection Customer shall pay a tax gross-up for the cost consequences of any current tax liability imposed on Interconnecting Transmission Owner, calculated using the methodology described in Article 5.17.4 and in accordance with IRS Notice 90-60.

5.17.7 Contests. In the event any Governmental Authority determines that Interconnecting Transmission Owner's receipt of payments or property constitutes income that is subject to taxation, Interconnecting Transmission Owner shall notify Interconnection Customer, in writing, within thirty (30) Calendar Days of receiving notification of such determination by a Governmental Authority. Upon the timely written request by Interconnection Customer and at Interconnection Customer's sole expense, Interconnecting Transmission Owner may appeal, protest, seek abatement of, or otherwise oppose such determination. Upon Interconnection Customer's written request and sole expense, Interconnecting Transmission Owner may file a claim for refund with respect to any taxes paid under this Article 5.17, whether or not it has received such a determination. Interconnecting Transmission Owner reserves the right to make all decisions with regard to the prosecution of such appeal, protest, abatement or other contest,

including the selection of counsel and compromise or settlement of the claim, but Interconnecting Transmission Owner shall keep Interconnection Customer informed, shall consider in good faith suggestions from Interconnection Customer about the conduct of the contest, and shall reasonably permit Interconnection Customer or an Interconnection Customer representative to attend contest proceedings.

Interconnection Customer shall pay to Interconnecting Transmission Owner on a periodic basis, as invoiced by Interconnecting Transmission Owner, documented reasonable costs of prosecuting such appeal, protest, abatement or other contest. At any time during the contest, Interconnecting Transmission Owner may agree to a settlement either with Interconnection Customer's consent or after obtaining written advice from nationally -recognized tax counsel, selected by Interconnecting Transmission Owner, but reasonably acceptable to Interconnection Customer, that the proposed settlement represents a reasonable settlement given the hazards of litigation. Interconnection Customer's obligation shall be based on the amount of the settlement agreed to by Interconnection Customer, or if a higher amount, so much of the settlement that is supported by the written advice from nationally recognized tax counsel selected under the terms of the preceding sentence. The settlement amount shall be calculated on a fully grossed-up basis to cover any related cost consequences of the current tax liability. Any settlement without Interconnection Customer's consent or such written advice will relieve Interconnection Customer from any obligation to indemnify Interconnecting Transmission Owner for the tax at issue in the contest.

5.17.8 Refund. In the event that (a) a private letter ruling is issued to Interconnecting Transmission Owner which holds that any amount paid or the value of any property transferred by Interconnection Customer to Interconnecting Transmission Owner under the terms of this LGIA is not subject to federal income taxation, (b) any legislative change or administrative announcement, notice, ruling or other determination makes it reasonably clear to Interconnecting Transmission Owner in good faith that any amount paid or the value of any property transferred by Interconnection Customer to Interconnecting Transmission Owner under the terms of this LGIA is not taxable to Interconnecting Transmission Owner, (c) any abatement, appeal, protest, or other contest results in a determination that any payments or transfers made by Interconnection Customer to Interconnecting Transmission Owner are not subject to federal income tax, or (d) if Interconnecting Transmission Owner receives a

refund from any taxing authority for any overpayment of tax attributable to any payment or property transfer made by Interconnection Customer to Interconnecting Transmission Owner pursuant to this LGIA, Interconnecting Transmission Owner shall promptly refund to Interconnection Customer the following:

(i) any payment made by Interconnection Customer under this Article 5.17 for taxes that is attributable to the amount determined to be non-taxable, together with interest thereon,(ii) interest on any amounts paid by Interconnection Customer to Interconnecting Transmission Owner for such taxes which Interconnecting Transmission Owner did not submit to the taxing authority, interest calculated in accordance with the methodology set forth in the Commission's regulations at 18 CFR §35.19a(a)(2)(iii) from the date payment was made by Interconnection Customer to the date Interconnecting Transmission Owner refunds such payment to Interconnection Customer, and

(iii) with respect to any such taxes paid by Interconnecting Transmission Owner, any refund or credit Interconnecting Transmission Owner receives or to which it may be entitled from any Governmental Authority, interest (or that portion thereof attributable to the payment described in clause (i), above) owed to the Interconnecting Transmission Owner for such overpayment of taxes (including any reduction in interest otherwise payable by Interconnecting Transmission Owner to any Governmental Authority resulting from an offset or credit); provided, however, that Interconnecting Transmission Owner will remit such amount promptly to Interconnection Customer only after and to the extent that Interconnecting Transmission Owner has received a tax refund, credit or offset from any Governmental Authority for any applicable overpayment of income tax related to the Interconnecting Transmission Owner's Interconnection Facilities.

The intent of this provision is to leave parties, to the extent practicable, in the event that no taxes are due with respect to any payment for Interconnection Facilities and Network Upgrades hereunder, in the same position they would have been in had no such tax payments been made.

5.17.9 Taxes Other Than Income Taxes. Upon the timely request by Interconnection Customer, and at Interconnection Customer's sole expense, Interconnecting Transmission Owner shall appeal, protest, seek abatement of, or otherwise contest any tax (other than federal or state income tax) asserted or assessed against Interconnecting Transmission Owner for which Interconnection Customer may be required to reimburse Interconnecting Transmission Owner under the terms of this LGIA. Interconnection Customer shall pay to Interconnecting Transmission Owner on a periodic basis, as invoiced by Interconnecting Transmission Owner, Interconnecting Transmission Owner's documented reasonable costs of prosecuting such appeal, protest, abatement, or other contest. Interconnection Customer and Interconnecting Transmission Owner shall cooperate in good faith with respect to any such contest. Unless the payment of such taxes is a prerequisite to an appeal or abatement or cannot be deferred, no amount shall be payable by Interconnection Customer to Interconnecting Transmission Owner for such taxes until they are assessed by a final, non-appealable order by any court or agency of competent jurisdiction. In the event that a tax payment is withheld and ultimately due and payable after appeal, Interconnection Customer will be responsible for all taxes, interest and penalties, other than penalties attributable to any delay caused by Interconnecting Transmission Owner.

5.18 Tax Status. Each Party shall cooperate with the others to maintain the other Party's(ies') tax status. Nothing in this LGIA is intended to adversely affect any Interconnecting Transmission Owner's tax-exempt status with respect to the issuance of bonds including, but not limited to, Local Furnishing Bonds.

5.19 Modification.

5.19.1 General. Either Interconnection Customer or Interconnecting Transmission Owner may undertake modifications to its facilities. If a Party plans to undertake a modification that reasonably may be expected to affect the other Party's facilities, the facilities of any Affected Parties, or the New England Transmission System, that Party shall provide to the other Parties and any Affected Party: (i) sufficient information regarding such modification so that the other Party(ies) may evaluate the potential impact of such modification prior to commencement of the work; and (ii) such information as may be required by the ISO New England Operating Documents, Applicable Reliability Standards, or successor documents. Such information shall be deemed to be confidential hereunder and shall include information concerning the timing of such modifications and whether such

modifications are expected to interrupt the flow of electricity from the Large Generating Facility. The Party desiring to perform such work shall provide the relevant drawings, plans, and specifications to the other Party(ies) at least ninety (90) Calendar Days in advance of the commencement of the work or such shorter period upon which the Parties may agree, which agreement shall not unreasonably be withheld, conditioned or delayed. Notwithstanding the foregoing, no party shall be obligated to proceed with a modification that would constitute a Material Modification or an Interconnection Request under the LGIP, except as provided under and pursuant to the LGIP.

In the case of Large Generating Facility modifications that do not require Interconnection Customer to submit an Interconnection Request, Interconnecting Transmission Owner shall provide, within thirty (30) Calendar Days (or such other time as the Parties may agree), an estimate of any additional modifications to the New England Transmission System, Interconnecting Transmission Owner's Interconnection Facilities or Network Upgrades necessitated by such Interconnection Customer modification and a good faith estimate of the costs thereof.

5.19.2 Standards. Any additions, modifications, or replacements made to a Party's facilities shall be designed, constructed and operated in accordance with this LGIA and Good Utility Practice.

5.19.3 Modification Costs. Interconnection Customer shall not be directly assigned for the costs of any additions, modifications, or replacements that Interconnecting Transmission Owner makes to the Interconnecting Transmission Owner's Interconnection Facilities or the New England Transmission System to facilitate the interconnection of a third party to the Interconnecting Transmission Owner's Interconnection Facilities or the New England Transmission System, or to provide transmission service to a third party under the Tariff, except as provided for under the Tariff or any other applicable tariff. Interconnection Customer shall be responsible for the costs of any additions, modifications, or replacements to the Interconnection Customer Interconnection Facilities that may be necessary to maintain or upgrade such Interconnection Customer Interconnection Facilities consistent with Applicable Laws and Regulations, Applicable Reliability Standards or Good Utility Practice.

ARTICLE 6. TESTING AND INSPECTION

- 6.1 Pre-Commercial Operation Date Testing and Modifications.** Prior to the Commercial Operation Date, the Interconnecting Transmission Owner shall test Interconnecting Transmission Owner's Interconnection Facilities and Network Upgrades and Interconnection Customer shall test the Large Generating Facility and the Interconnection Customer's Interconnection Facilities to ensure their safe and reliable operation. Similar testing may be required after initial operation. Each Party shall make any modifications to its facilities that are found to be necessary as a result of such testing. Interconnection Customer shall bear the cost of all such testing and modifications. Interconnection Customer shall generate test energy at the Large Generating Facility only if it has arranged for the delivery of such test energy.
- 6.2 Post-Commercial Operation Date Testing and Modifications.** Each Interconnection Customer and Interconnecting Transmission Owner shall at its own expense perform routine inspection and testing of its facilities and equipment in accordance with ISO New England Operating Documents, Applicable Reliability Standards, or successor documents, as may be necessary to ensure the continued interconnection of the Large Generating Facility to the Administered Transmission System in a safe and reliable manner. The Interconnection Customer and Interconnecting Transmission Owner each shall have the right, upon advance written notice, to require reasonable additional testing of the other Party's(ies') facilities, at the requesting Party's expense, as may be in accordance with the ISO New England Operating Documents, Applicable Reliability Standards, or successor documents. The System Operator shall also have the right to require reasonable additional testing of the other Party's (ies') facilities in accordance with the ISO New England Operating Documents, Applicable Reliability Standards, or successor documents.
- 6.3 Right to Observe Testing.** Each Party shall notify the System Operator and other Party(ies) in advance of its performance of tests of its Interconnection Facilities. The other Party(ies) has the right, at its own expense, to observe such testing.
- 6.4 Right to Inspect.** Each Party shall have the right, but shall have no obligation to: (i) observe the other Party's(ies') tests and/or inspection of any of its System Protection Facilities and other protective equipment, including Power System Stabilizers; (ii) review the settings of the other Party's(ies') System Protection Facilities and other protective equipment; and (iii) review the other Party's(ies') maintenance records relative to the Interconnection Facilities, the System Protection Facilities and other protective

equipment. Each Party may exercise these rights from time to time as it deems necessary upon reasonable notice to the other Parties. The exercise or non-exercise by a Party of any such rights shall not be construed as an endorsement or confirmation of any element or condition of the Interconnection Facilities or the System Protection Facilities or other protective equipment or the operation thereof, or as a warranty as to the fitness, safety, desirability, or reliability of same. Any information that a Party obtains through the exercise of any of its rights under this Article 6.4 shall be governed by Article 22.

ARTICLE 7. METERING

- 7.1 General.** Each Party shall comply with the ISO New England Operating Documents, Applicable Reliability Standards, or successor documents, regarding metering. Interconnection Customer shall bear all reasonable documented costs associated with the purchase, installation, operation, testing and maintenance of the Metering Equipment. Unless the System Operator otherwise agrees, the Interconnection Customer shall be responsible for installing and maintaining compatible metering and communications equipment to accurately account for the capacity and energy being transmitted under this Tariff and to communicate the information to the System Operator. Unless otherwise agreed, such equipment shall remain the property of the Interconnecting Transmission Owner.
- 7.2 Check Meters.** Interconnection Customer, at its option and expense, may install and operate, on its premises and on its side of the Point of Interconnection, one or more check meters to check Interconnecting Transmission Owner's meters. Such check meters shall be for check purposes only and shall not be used for the measurement of power flows for purposes of this LGIA, except as provided in Article 7.4 below. The check meters shall be subject at all reasonable times to inspection and examination by Interconnecting Transmission Owner or its designee. The installation, operation and maintenance thereof shall be performed entirely by Interconnection Customer in accordance with Good Utility Practice.
- 7.3 Standards.** Interconnecting Transmission Owner shall install, calibrate, and test revenue quality Metering Equipment in accordance with applicable ANSI standards and the ISO New England Operating Documents, Applicable Reliability Standards, or successor documents.
- 7.4 Testing of Metering Equipment.** Interconnecting Transmission Owner shall inspect and test all Interconnecting Transmission Owner-owned Metering Equipment upon

installation and thereafter as specified in the ISO New England Operating Documents, Applicable Reliability Standards, or successor documents. Interconnecting Transmission Owner shall give reasonable notice of the time when any inspection or test shall take place, and Interconnection Customer may have representatives present at the test or inspection. If at any time Metering Equipment is found to be inaccurate or defective, it shall be adjusted, repaired or replaced at Interconnection Customer's expense, in order to provide accurate metering. If Metering Equipment fails to register, or if the measurement made by Metering Equipment during a test varies by more than the values specified within ISO New England Operating Documents, or successor documents, from the measurement made by the standard meter used in the test, the Interconnecting Transmission Owner shall adjust the measurements, in accordance with the ISO New England Operating Documents, Applicable Reliability Standards, or successor documents.

- 7.5 Metering Data.** At Interconnection Customer's expense, metered data shall be telemetered to one or more locations designated by System Operator and Interconnecting Transmission Owner. The hourly integrated metering, established in accordance with ISO New England Operating Documents, Applicable Reliability Standards, or successor documents, used to transmit Megawatt hour ("MWh") per hour data by electronic means and the Watt-hour meters equipped with kilowatt-hour ("kwh") or MWh registers to be read at month's end shall be the official measurement of the amount of energy delivered from the Large Generating Facility to the Point of Interconnection. Instantaneous metering is required for all Generators in accordance with ISO New England Operating Documents, Applicable Reliability Standards, or successor documents.

ARTICLE 8. COMMUNICATIONS

- 8.1 Interconnection Customer Obligations.** Interconnection Customer shall maintain satisfactory operating communications with the System Operator and Interconnecting Transmission Owner in accordance with applicable provisions of ISO New England Operating Documents, Applicable Reliability Standards, or successor documents.
- 8.2 Remote Terminal Unit.** Prior to the Initial Synchronization Date of the Large Generating Facility, a Remote Terminal Unit, or equivalent data collection and transfer equipment acceptable to the Parties, shall be installed by Interconnection Customer or Interconnecting Transmission Owner at Interconnection Customer's expense, to gather accumulated and instantaneous data to be telemetered to the location(s) designated by System Operator and Interconnecting Transmission Owner through use of a dedicated

point-to-point data circuit(s). The communication protocol for the data circuit(s) shall be specified by System Operator and Interconnecting Transmission Owner. All information required by the ISO New England Operating Documents, or successor documents, must be telemetered directly to the location(s) specified by System Operator and Interconnecting Transmission Owner.

Each Party will promptly advise the other Party(ies) if it detects or otherwise learns of any metering, telemetry or communications equipment errors or malfunctions that require the attention and/or correction by the other Party(ies). The Party owning such equipment shall correct such error or malfunction as soon as reasonably feasible.

- 8.3 No Annexation.** Any and all equipment placed on the premises of a Party shall be and remain the property of the Party providing such equipment regardless of the mode and manner of annexation or attachment to real property, unless otherwise mutually agreed by the Parties.

ARTICLE 9. OPERATIONS

- 9.1 General.** Each Party shall comply with applicable provisions of ISO New England Operating Documents, Reliability Standards, or successor documents, regarding operations. Each Party shall provide to the other Party(ies) all information that may reasonably be required by the other Party(ies) to comply with Applicable Laws and Regulations and Applicable Reliability Standards.
- 9.2 Control Area Notification.** Before Initial Synchronization Date, the Interconnection Customer shall notify the System Operator and Interconnecting Transmission Owner in writing in accordance with ISO New England Operating Documents, Reliability Standards, or successor documents. If the Interconnection Customer elects to have the Large Generating Facility dispatched and operated from a remote Control Area other than the Control Area in which the Large Generating Facility is physically located, and if permitted to do so by the relevant transmission tariffs and ISO New England Operating Documents, Reliability Standards, or successor documents, all necessary arrangements, including but not limited to those set forth in Article 7 and Article 8 of this LGIA, and remote Control Area generator interchange agreements, if applicable, and the appropriate measures under such agreements, shall be executed and implemented prior to the placement of the Large Generating Facility in the other Control Area for dispatch and operations.

9.3 Interconnecting Transmission Owner and System Operator Obligations.

Interconnecting Transmission Owner and System Operator shall cause the Interconnecting Transmission Owner's Interconnection Facilities to be operated, maintained and controlled in a safe and reliable manner and in accordance with this LGIA and ISO New England Operating Documents, Reliability Standards, or successor documents. Interconnecting Transmission Owner or System Operator may provide operating instructions to Interconnection Customer consistent with this LGIA, ISO New England Operating Documents, Applicable Reliability Standards, or successor documents, and Interconnecting Transmission Owner's and System Operator's operating protocols and procedures as they may change from time to time. Interconnecting Transmission Owner and System Operator will consider changes to their operating protocols and procedures proposed by Interconnection Customer.

9.4 Interconnection Customer Obligations. Interconnection Customer shall at its own expense operate, maintain and control the Large Generating Facility and the Interconnection Customer Interconnection Facilities in a safe and reliable manner and in accordance with this LGIA and ISO New England Operating Documents, Applicable Reliability Standards, or successor documents.

9.5 Start-Up and Synchronization. The Interconnection Customer is responsible for the proper start-up and synchronization of the Large Generating Facility to the New England Transmission System in accordance with ISO New England Operating Documents, Applicable Reliability Standards, or successor documents.

9.6 Reactive Power.

9.6.1 Power Factor Design Criteria. Interconnection Customer shall design the Large Generating Facility to maintain a composite power delivery at continuous rated power output at the Point of Interconnection at a power factor within the range of 0.95 leading to 0.95 lagging, unless the System Operator or Interconnecting Transmission Owner has established different requirements that apply to all generators in the Control Area on a comparable basis and in accordance with ISO New England Operating Documents, Applicable Reliability Standards, or successor documents. The requirements of this paragraph shall not apply to wind generators.

9.6.2 Voltage Schedules. Once the Interconnection Customer has synchronized the Large Generating Facility to the New England Transmission

System, Interconnection Customer shall operate the Large Generating Facility at the direction of System Operator and Interconnecting Transmission Owner in accordance with applicable provisions of the ISO New England Operating Documents, Applicable Reliability Standards, or successor documents, regarding voltage and provide voltage schedules in accordance with such requirements.

9.6.2.1 Voltage Regulators. The Interconnection Customer must keep and maintain a voltage regulator on all generating units comprising a Generator in accordance with the ISO New England Operating Documents, Applicable Reliability Standards, or successor documents. All interconnected generators that have, or are required to have, automatic voltage regulation shall normally operate the Large Generating Facility with its voltage regulators in automatic operation.

It is the responsibility of the Interconnection Customer to maintain the voltage regulator in good operating condition and promptly report to the System Operator and Interconnecting Transmission Owner any problems that could cause interference with its proper operation.

9.6.2.2 Governor Control. The Interconnection Customer is obligated to provide and maintain a functioning governor on all Generating Facilities in accordance with applicable provisions of the ISO New England Operating Documents, Applicable Reliability Standards, or successor documents.

9.6.2.3 System Protection. The Interconnection Customer shall install and maintain protection systems in accordance with applicable provisions of the ISO New England Operating Documents, Applicable Reliability Standards, or successor documents, regarding system protection.

9.6.3 Payment for Reactive Power.

Interconnection Customers shall be compensated for Reactive Power service in accordance with Schedule 2 of the Section II of the Tariff.

9.7 Outages and Interruptions.

9.7.1 Outages.

- 9.7.1.1 Outage Authority and Coordination.** The System Operator shall have the authority to coordinate facility outages in accordance with the ISO New England Operating Documents, Applicable Reliability Standards, or successor documents. Each Party may in accordance with the ISO New England Operating Documents, Applicable Reliability Standards, or successor documents, in coordination with the other Party(ies), remove from service any of its respective Interconnection Facilities or Network Upgrades that may impact the other Party's(ies') facilities as necessary to perform maintenance or testing or to install or replace equipment, subject to the oversight of System Operator in accordance with the ISO New England Operating Documents, Applicable Reliability Standards, or successor documents.
- 9.7.1.2 Outage Schedules.** Outage scheduling, and any related compensation, shall be in accordance with the applicable provisions of the ISO New England Operating Documents, Applicable Reliability Standards, or successor documents.
- 9.7.2 Interruption of Service.** In accordance with the ISO New England Operating Documents, Applicable Reliability Standards, or successor documents, the System Operator or Interconnecting Transmission Owner may require Interconnection Customer to interrupt or reduce deliveries of electricity if such delivery of electricity could adversely affect System Operator's or Interconnecting Transmission Owner's ability to perform such activities as are necessary to safely and reliably operate and maintain the New England Transmission System.
- 9.7.3 Under-Frequency and Over Frequency Conditions.** Interconnection Customer shall implement under-frequency and over-frequency relay set points for the Large Generating Facility as required by the applicable provisions of ISO New England Operating Documents, Applicable Reliability Standards, or successor documents. Large Generating Facility response to frequency deviations of pre-determined magnitudes, both under-frequency and over-frequency deviations, shall be studied and coordinated with System Operator and Interconnecting Transmission Owner in accordance with ISO New England Operating Documents, Applicable Reliability Standards, or successor documents.
- 9.7.4 System Protection and Other Control Requirements.**

9.7.4.1 System Protection Facilities. Interconnection Customer shall, at its expense, install, operate and maintain System Protection Facilities as a part of the Large Generating Facility or the Interconnection Customer Interconnection Facilities in accordance with the ISO New England Operating Documents, Applicable Reliability Standards, or successor documents. Interconnecting Transmission Owner shall install at Interconnection Customer's expense, in accordance with the ISO New England Operating Documents, Applicable Reliability Standards, or successor documents, any System Protection Facilities that may be required on the Interconnecting Transmission Owner Interconnection Facilities or the New England Transmission System as a result of the interconnection of the Large Generating Facility and the Interconnection Customer Interconnection Facilities.

9.7.4.2 Each Party's protection facilities shall be designed and coordinated with other systems in accordance with the ISO New England Operating Documents, Applicable Reliability Standards, or successor documents.

9.7.4.3 Each Party shall be responsible for protection of its facilities consistent with the ISO New England Operating Documents, Applicable Reliability Standards, or successor documents.

9.7.4.4 Each Party's protective relay design shall allow for tests required in Article 6.

9.7.4.5 Each Party will test, operate and maintain System Protection Facilities in accordance with the ISO New England Operating Documents, Applicable Reliability Standards, or successor documents.

9.7.5 Requirements for Protection. In accordance with the ISO New England Operating Documents, Applicable Reliability Standards, or successor documents, and compliance with Good Utility Practice, Interconnection Customer shall provide, install, own, and maintain relays, circuit breakers and all other devices necessary to remove any fault contribution of the Large Generating Facility to any short circuit occurring on the New England Transmission System not otherwise isolated by Interconnecting Transmission Owner's equipment, such that the removal of the fault contribution shall be coordinated with the protective requirements of the New England Transmission System. Such protective

equipment shall include, without limitation, a disconnecting device or switch with load-interrupting capability located between the Large Generating Facility and the New England Transmission System at a site selected upon mutual agreement (not to be unreasonably withheld, conditioned or delayed) of the Parties.

Interconnection Customer shall be responsible for protection of the Large Generating Facility and Interconnection Customer's other equipment from such conditions as negative sequence currents, over- or under-frequency, sudden load rejection, over- or under-voltage, and generator loss-of-field. Interconnection Customer shall be solely responsible to disconnect the Large Generating Facility and Interconnection Customer's other equipment if conditions on the New England Transmission System could adversely affect the Large Generating Facility.

9.7.6 Power Quality. A Party's facilities shall not cause excessive voltage flicker nor introduce excessive distortion to the sinusoidal voltage or current waves as defined by ANSI Standard C84.1-1989, in accordance with IEEE Standard 519, or any applicable superseding electric industry standard.

9.8 Switching and Tagging Rules. Each Party shall provide the other Party(ies) with a copy of its switching and tagging rules that are applicable to the other Party's activities. Such switching and tagging rules shall be developed on a non-discriminatory basis. The Parties shall comply with applicable switching and tagging rules, as amended from time to time, in obtaining clearances for work or for switching operations on equipment.

9.9 Use of Interconnection Facilities by Third Parties.

9.9.1 Purpose of Interconnection Facilities. Except as may be required by Applicable Laws and Regulations, or as otherwise agreed to among the Parties, the Interconnection Facilities shall be constructed for the sole purpose of interconnecting the Large Generating Facility to the Administered Transmission System and shall be used for no other purpose.

9.9.2 Third Party Users. If required by Applicable Laws and Regulations or if the Parties mutually agree, such agreement not to be unreasonably withheld, to allow one or more third parties to use the Interconnecting Transmission Owner's Interconnection Facilities, or any part thereof, Interconnection Customer will be entitled to compensation for the capital expenses it incurred in connection with the Interconnection Facilities based upon the pro rata use of the Interconnection

Facilities by Interconnecting Transmission Owner, all third party users, and Interconnection Customer, in accordance with Applicable Laws and Regulations or upon some other mutually agreed-upon methodology. In addition, cost responsibility for ongoing costs, including operation and maintenance costs associated with the Interconnection Facilities, will be allocated between Interconnection Customer and any third party users based upon the pro rata use of the Interconnection Facilities by Interconnecting Transmission Owner, all third party users, and Interconnection Customer, in accordance with Applicable Laws and Regulations or upon some other mutually agreed-upon methodology. If the issue of such compensation or allocation cannot be resolved through such negotiations, it shall be submitted to the Commission for resolution.

- 9.10 Disturbance Analysis Data Exchange.** The Parties will cooperate with one another in the analysis of disturbances to either the Large Generating Facility or the New England Transmission System by gathering and providing access to any information relating to any disturbance, including information from oscillography, protective relay targets, breaker operations and sequence of events records, and any disturbance information required by the ISO New England Operating Documents, Applicable Reliability Standards, or successor documents.

ARTICLE 10. MAINTENANCE

- 10.1 Interconnecting Transmission Owner and Customer Obligations.** Interconnecting Transmission Owner and Interconnection Customer shall each maintain that portion of its respective facilities that are part of the New England Transmission System and the Interconnecting Transmission Owner's Interconnection Facilities in a safe and reliable manner and in accordance with the applicable provisions of the ISO New England Operating Documents, Applicable Reliability Standards, or successor documents.
- 10.2 Operating and Maintenance Expenses.** Subject to the provisions herein addressing the use of facilities by others, and except for operations and maintenance expenses associated with modifications made for providing interconnection or transmission service to a third party and such third party pays for such expenses, Interconnection Customer shall be responsible for all reasonable expenses including overheads, associated with: (1) owning, operating, maintaining, repairing, and replacing Interconnection Customer Interconnection Facilities; and (2) operation, maintenance, repair and replacement of Interconnecting Transmission Owner's Interconnection Facilities, Stand Alone Network Upgrades, Network Upgrades and Distribution Upgrades.

ARTICLE 11. PERFORMANCE OBLIGATION

- 11.1 Interconnection Customer Interconnection Facilities.** Interconnection Customer shall design, procure, construct, install, own and/or control the Interconnection Customer Interconnection Facilities described in Appendix A (Interconnection Facilities, Network Upgrades and Distribution Upgrades) at its sole expense.
- 11.2 Interconnecting Transmission Owner’s Interconnection Facilities.** Interconnecting Transmission Owner shall design, procure, construct, install, own and/or control the Interconnecting Transmission Owner’s Interconnection Facilities described in Appendix A (Interconnection Facilities, Network Upgrades and Distribution Upgrades) at the sole expense of the Interconnection Customer.
- 11.3 Network Upgrades and Distribution Upgrades.** Interconnecting Transmission Owner shall design, procure, construct, install, and own the Network Upgrades, and to the extent provided by Article 5.1, Stand Alone Network Upgrades, and Distribution Upgrades described in Appendix A (Interconnection Facilities, Network Upgrades and Distribution Upgrades). The Interconnection Customer shall be responsible for all costs related to Distribution Upgrades. Unless the Interconnecting Transmission Owner elects to fund the capital for the Network Upgrades, they shall be solely funded by the Interconnection Customer.
- 11.4 Cost Allocation; Compensation; Rights; Affected Systems**
- 11.4.1 Cost Allocation.** Cost allocation of Generator Interconnection Related Upgrades shall be in accordance with Schedule 11 of Section II of the Tariff.
- 11.4.2 Compensation.** Any compensation due to the Interconnection Customer for increases in transfer capability to the PTF resulting from its Generator Interconnection Related Upgrade shall be determined in accordance with Sections II and III of the Tariff.
- 11.4.3 Rights.** Notwithstanding any other provision of this LGIA, nothing herein shall be construed as relinquishing or foreclosing any rights, including but not limited to firm transmission rights, capacity rights, transmission congestion rights, or transmission credits, that the Interconnection Customer shall be entitled to, now or in the future, under any other agreement or tariff as a result of, or otherwise associated with, the transmission capacity, if any, created by the Network Upgrades.

- 11.4.4 Special Provisions for Affected Systems.** The Interconnection Customer shall enter into separate related facilities agreements to address any upgrades to the Affected System(s) that are necessary for safe and reliable interconnection of the Interconnection Customer's Generating Facility.
- 11.5 Provision of Security.** At least thirty (30) Calendar Days prior to the commencement of the procurement, installation, or construction of a discrete portion of an Interconnecting Transmission Owner's Interconnection Facilities, Network Upgrades, or Distribution Upgrades, Interconnection Customer shall provide Interconnecting Transmission Owner a guarantee, a surety bond, letter of credit or other form of security that is reasonably acceptable to Interconnecting Transmission Owner in accordance with Section 7 of Schedule 11 of the Tariff. In addition:
- 11.5.1** The guarantee must be made by an entity that meets the creditworthiness requirements of Interconnecting Transmission Owner, and contain terms and conditions that guarantee payment of any amount that may be due from Interconnection Customer, up to an agreed-to maximum amount.
- 11.5.2** The letter of credit must be issued by a financial institution reasonably acceptable to Interconnecting Transmission Owner and must specify a reasonable expiration date.
- 11.5.3** The surety bond must be issued by an insurer reasonably acceptable to Interconnecting Transmission Owner and must specify a reasonable expiration date.
- 11.6 Interconnection Customer Compensation.** If System Operator or Interconnecting Transmission Owner requests or directs Interconnection Customer to provide a service pursuant to Articles 9.6.3 (Payment for Reactive Power), or 13.4.1 of this LGIA, Interconnection Customer shall be compensated pursuant to the ISO New England Operating Documents, Applicable Reliability Standards, or successor documents.
- 11.6.1 Interconnection Customer Compensation for Actions During Emergency Condition.** Interconnection Customer shall be compensated for its provision of real and reactive power and other Emergency Condition services that Interconnection Customer provides to support the New England Transmission System during an Emergency Condition in accordance with the ISO New England Operating Documents, Applicable Reliability Standards, or successor documents.

ARTICLE 12. INVOICE

- 12.1 General.** Each Party shall submit to the other Party(ies), on a monthly basis, invoices of amounts due for the preceding month. Each invoice shall state the month to which the invoice applies and fully describe the services and equipment provided. The Parties may discharge mutual debts and payment obligations due and owing to each other on the same date through netting, in which case all amounts a Party owes to the other Party(ies) under this LGIA, including interest payments or credits, shall be netted so that only the net amount remaining due shall be paid by the owing Party.
- 12.2 Final Invoice.** Within six months after completion of the construction of the Interconnecting Transmission Owner's Interconnection Facilities and the Network Upgrades, Interconnecting Transmission Owner shall provide an invoice of the final cost of the construction of the Interconnecting Transmission Owner's Interconnection Facilities and the Network Upgrades and shall set forth such costs in sufficient detail to enable Interconnection Customer to compare the actual costs with the estimates and to ascertain deviations, if any, from the cost estimates. Interconnecting Transmission Owner shall refund to Interconnection Customer any amount by which the actual payment by Interconnection Customer for estimated costs exceeds the actual costs of construction within thirty (30) Calendar Days of the issuance of such final construction invoice. Interconnection Customer shall pay to Interconnecting Transmission Owner any amount by which the actual payment by Interconnection Customer for estimated costs falls short of the actual costs of construction within thirty (30) Calendar Days of the issuance of such final construction invoice.
- 12.3 Payment.** Invoices shall be rendered to the paying Party at the address specified in Appendix F. The Party receiving the invoice shall pay the invoice within thirty (30) Calendar Days of receipt. All payments shall be made in immediately available funds payable to the other Party, or by wire transfer to a bank named and account designated by the invoicing Party. Payment of invoices by any Party will not constitute a waiver of any rights or claims the other Party(ies) may have under this LGIA.
- 12.4 Disputes.** In the event of a billing dispute between Interconnecting Transmission Owner and Interconnection Customer, Interconnecting Transmission Owner shall continue to provide Interconnection Service under this LGIA as long as Interconnection Customer: (i) continues to make all payments not in dispute; and (ii) pays to Interconnecting Transmission Owner or into an independent escrow account the portion of the invoice in dispute, pending resolution of such dispute. If Interconnection Customer fails to meet

these two requirements for continuation of service, then Interconnecting Transmission Owner may provide notice to Interconnection Customer of a Default pursuant to Article 17. Within thirty (30) Calendar Days after the resolution of the dispute, the Party that owes money to the other Party shall pay the amount due with interest calculated in accord with the methodology set forth in the Commission's Regulations at 18 CFR § 35.19a(a)(2)(iii).

ARTICLE 13. EMERGENCIES

- 13.1 Obligations.** Each Party shall comply with the Emergency Condition procedures of the System Operator in accordance with the applicable provisions of the ISO New England Operating Documents, Applicable Reliability Standards, or successor documents.
- 13.2 Notice.** Interconnecting Transmission Owner or System Operator as applicable shall notify Interconnection Customer and System Operator or Interconnecting Transmission Owner as applicable, promptly when it becomes aware of an Emergency Condition that affects the Interconnecting Transmission Owner's Interconnection Facilities or the New England Transmission System that may reasonably be expected to affect Interconnection Customer's operation of the Large Generating Facility or the Interconnection Customer's Interconnection Facilities. Interconnection Customer shall notify Interconnecting Transmission Owner and System Operator promptly when it becomes aware of an Emergency Condition that affects the Large Generating Facility or the Interconnection Customer Interconnection Facilities that may reasonably be expected to affect the New England Transmission System or the Interconnecting Transmission Owner's Interconnection Facilities. To the extent information is known, the notification shall describe the Emergency Condition, the extent of the damage or deficiency, the expected effect on the operation of Interconnection Customer's or Interconnecting Transmission Owner's facilities and operations, its anticipated duration and the corrective action taken and/or to be taken. The initial notice shall be followed as soon as practicable with written notice.
- 13.3 Immediate Action.** Unless, in Interconnection Customer's reasonable judgment, immediate action is required, Interconnection Customer shall obtain the consent of Interconnecting Transmission Owner and System Operator, such consent to not be unreasonably withheld, prior to performing any manual switching operations at the Large Generating Facility or the Interconnection Customer Interconnection Facilities in response to an Emergency Condition either declared by the Interconnecting Transmission

Owner or the System Operator or otherwise regarding the New England Transmission System.

13.4 System Operator's and Interconnecting Transmission Owner's Authority.

13.4.1 General. System Operator or Interconnecting Transmission Owner may take whatever actions or inactions with regard to the New England Transmission System or the Interconnecting Transmission Owner's Interconnection Facilities it deems necessary during an Emergency Condition in order to (i) preserve public health and safety, (ii) preserve the reliability of the New England Transmission System or Interconnecting Transmission Owner's Interconnection Facilities, (iii) limit or prevent damage, and (iv) expedite restoration of service.

System Operator and Interconnecting Transmission Owner shall use Reasonable Efforts to minimize the effect of such actions or inactions on the Large Generating Facility or the Interconnection Customer Interconnection Facilities. System Operator and Interconnecting Transmission Owner may, on the basis of technical considerations, require the Large Generating Facility to mitigate an Emergency Condition by taking actions necessary and limited in scope to remedy the Emergency Condition, including, but not limited to, directing Interconnection Customer to shut-down, start-up, increase or decrease the real or reactive power output of the Large Generating Facility; implementing a reduction or disconnection pursuant to Article 13.4.2; directing the Interconnection Customer to assist with black start (if available) or restoration efforts; or altering the outage schedules of the Large Generating Facility and the Interconnection Customer Interconnection Facilities. Interconnection Customer shall comply with all of System Operator's and Interconnecting Transmission Owner's operating instructions concerning Large Generating Facility real power and reactive power output within the manufacturer's design limitations of the Large Generating Facility's equipment that is in service and physically available for operation at the time, in compliance with Applicable Laws and Regulations.

13.4.2 Reduction and Disconnection. System Operator and Interconnecting Transmission Owner may reduce Interconnection Service or disconnect the Large Generating Facility or the Interconnection Customer Interconnection Facilities when such reduction or disconnection is necessary in accordance with the ISO New England Operating Documents, Applicable Reliability Standards, or successor documents. These rights are separate and distinct from any right of

curtailment of the System Operator and Interconnecting Transmission Owner pursuant to the Tariff. When the System Operator and Interconnecting Transmission Owner can schedule the reduction or disconnection in advance, System Operator and Interconnecting Transmission Owner shall notify Interconnection Customer of the reasons, timing and expected duration of the reduction or disconnection. System Operator and Interconnecting Transmission Owner shall coordinate with the Interconnection Customer in accordance with the ISO New England Operating Documents, Applicable Reliability Standards, or successor documents to schedule the reduction or disconnection during periods of least impact to the Interconnection Customer and the System Operator and Interconnecting Transmission Owner. Any reduction or disconnection shall continue only for so long as reasonably necessary in accordance with the ISO New England Operating Documents, Applicable Reliability Standards, or successor documents. The Parties shall cooperate with each other to restore the Large Generating Facility, the Interconnection Facilities, and the New England Transmission System to their normal operating state as soon as practicable in accordance with the ISO New England Operating Documents, Applicable Reliability Standards, or successor documents.

- 13.5 Interconnection Customer Authority.** In accordance with the ISO New England Operating Documents, Applicable Reliability Standards, or successor documents and the LGIA and the LGIP, the Interconnection Customer may take whatever actions or inactions with regard to the Large Generating Facility or the Interconnection Customer's Interconnection Facilities during an Emergency Condition in order to (i) preserve public health and safety, (ii) preserve the reliability of the Large Generating Facility or the Interconnection Customer's Interconnection Facilities, (iii) limit or prevent damage, and (iv) expedite restoration of service. Interconnection Customer shall use Reasonable Efforts to minimize the effect of such actions or inactions on the New England Transmission System and the Interconnecting Transmission Owner's Interconnection Facilities. System Operator and Interconnecting Transmission Owner shall use Reasonable Efforts to assist Interconnection Customer in such actions.
- 13.6 Limited Liability.** Except as otherwise provided in Article 11.6.1 of this LGIA, a Party shall not be liable to another Party for any action it takes in responding to an Emergency Condition so long as such action is made in good faith and in accordance with the ISO New England Operating Documents, Applicable Reliability Standards, or successor documents.

ARTICLE 14. REGULATORY REQUIREMENTS AND GOVERNING LAW

14.1 Regulatory Requirements. Each Party's obligations under this LGIA shall be subject to its receipt of any required approval or certificate from one or more Governmental Authorities in the form and substance satisfactory to the applying Party, or the Party making any required filings with, or providing notice to, such Governmental Authorities, and the expiration of any time period associated therewith. Each Party shall in good faith seek and use its Reasonable Efforts to obtain such other approvals. Nothing in this LGIA shall require Interconnection Customer to take any action that could result in its inability to obtain, or its loss of, status or exemption under the Federal Power Act or the Public Utility Holding Company Act of 1935, as amended. To the extent that a condition arises that could result in Interconnection Customer's inability to obtain, or its loss of, status or exemption under the Federal Power Act, the Public Utility Holding Company Act of 1935, as amended, or the Public Utility Regulatory Policies Act of 1978, the Parties shall engage in good faith negotiations to address the condition so that such result will not occur and so that the Interconnection Agreement can be performed.

14.2 Governing Law.

14.2.1 The validity, interpretation and performance of this LGIA and each of its provisions shall be governed by the laws of the state where the Point of Interconnection is located, without regard to its conflicts of law principles.

14.2.2 This LGIA is subject to all Applicable Laws and Regulations.

14.2.3 Each Party expressly reserves the right to seek changes in, appeal, or otherwise contest any laws, orders, rules, or regulations of a Governmental Authority.

ARTICLE 15. NOTICES

15.1 General. Unless otherwise provided in this LGIA, any notice, demand or request required or permitted to be given by a Party to another Party and any instrument required or permitted to be tendered or delivered by a Party in writing to another Party shall be effective when delivered and may be so given, tendered or delivered, by recognized national courier, or by depositing the same with the United States Postal Service with postage prepaid, for delivery by certified or registered mail, addressed to the Party, or personally delivered to the Party, at the address set out in Appendix F (Addresses for Delivery of Notices and Billings).

A Party may change the notice information in this LGIA by giving five (5) Business Days written notice prior to the effective date of the change.

15.2 Billings and Payments. Billings and payments shall be sent to the addresses set out in Appendix F.

15.3 Alternative Forms of Notice. Any notice or request required or permitted to be given by a Party to another Party and not required by this Agreement to be given in writing may be so given by telephone, facsimile or email to the telephone numbers and email addresses set out in Appendix F.

15.4 Operations and Maintenance Notice. Each Party shall notify the other Party(ies) in writing of the identity of the person(s) that it designates as the point(s) of contact with respect to the implementation of Articles 9 and 10.

ARTICLE 16. FORCE MAJEURE

16.1 Force Majeure.

16.1.1 Economic hardship is not considered a Force Majeure event.

16.1.2 A Party shall not be considered to be in Default with respect to any obligation hereunder (including obligations under Article 4), other than the obligation to pay money when due, if prevented from fulfilling such obligation by Force Majeure. A Party unable to fulfill any obligation hereunder (other than an obligation to pay money when due) by reason of Force Majeure shall give notice and the full particulars of such Force Majeure to the other Party(ies) in writing or by telephone as soon as reasonably possible after the occurrence of the cause relied upon. Telephone notices given pursuant to this Article shall be confirmed in writing as soon as reasonably possible and shall specifically state full particulars of the Force Majeure, the time and date when the Force Majeure occurred and when the Force Majeure is reasonably expected to cease. The Party affected shall exercise due diligence to remove such disability with reasonable dispatch, but shall not be required to accede or agree to any provision not satisfactory to it in order to settle and terminate a strike or other labor disturbance.

ARTICLE 17. DEFAULT

17.1 Default.

17.1.1 General. No Breach shall exist where such failure to discharge an obligation (other than the payment of money) is the result of Force Majeure as defined in this LGIA or the result of an act or omission of the other Party(ies). Upon a Breach, the non-Breaching Party shall give written notice of such Breach to the breaching Party. Except as provided in Article 17.1.2, the Breaching Party shall have thirty (30) Calendar Days from receipt of the Breach notice within which to cure such Breach; provided however, if such Breach is not capable of cure within thirty (30) Calendar Days, the Breaching Party shall commence such cure within thirty (30) Calendar Days after notice and continuously and diligently complete such cure within ninety (90) Calendar Days from receipt of the Breach notice; and, if cured within such time, the Breach specified in such notice shall cease to exist.

17.1.2 Right to Terminate. If a Breach is not cured as provided in this Article, or if a Breach is not capable of being cured within the period provided for herein, the non-breaching Party(ies) shall have the right to terminate this LGIA by written notice at any time until cure occurs, and be relieved of any further obligation hereunder and, whether or not those Parties terminate this LGIA, to recover from the Breaching Party all amounts due hereunder, plus all other damages and remedies to which they are entitled at law or in equity. The provisions of this Article will survive termination of this LGIA.

ARTICLE 18. INDEMNITY, CONSEQUENTIAL DAMAGES AND INSURANCE

Notwithstanding any other provision of this Agreement, the liability, indemnification and insurance provisions of the Transmission Operating Agreement (“TOA”) or other applicable operating agreements shall apply to the relationship between the System Operator and the Interconnection Transmission Owner and the liability, indemnification and insurance provisions of the Tariff apply to the relationship between the System Operator and the Interconnection Customer and between the Interconnecting Transmission Owner and the Interconnection Customer.

18.1 Indemnity. Each Party shall at all times indemnify, defend, and save the other Party(ies) harmless from any and all damages, losses, claims, including claims and actions relating to injury to or death of any person or damage to property, demand, suits, recoveries, costs and expenses, court costs, attorney fees, and all other obligations by or to third parties, arising out of or resulting from the other Party’s(ies’) action or inactions of their

obligations under this LGIA on behalf of the Indemnifying Party, except in cases of gross negligence or intentional wrongdoing by an indemnified Party.

18.1.1 Indemnified Person. If an Indemnified Person is entitled to indemnification under this Article 18 as a result of a claim by a third party, and the Indemnifying Party fails, after notice and reasonable opportunity to proceed under Article 18.1, to assume the defense of such claim, such Indemnified Person may at the expense of the Indemnifying Party contest, settle or consent to the entry of any judgment with respect to, or pay in full, such claim.

18.1.2 Indemnifying Party. If an Indemnifying Party is obligated to indemnify and hold any Indemnified Person harmless under this Article 18, the amount owing to the Indemnified Person shall be the amount of such Indemnified Person's actual Loss, net of any insurance or other recovery.

18.1.3 Indemnity Procedures. Promptly after receipt by an Indemnified Person of any claim or notice of the commencement of any action or administrative or legal proceeding or investigation as to which the indemnity provided for in Article 18.1 may apply, the Indemnified Person shall notify the Indemnifying Party of such fact. Any failure of or delay in such notification shall not affect a Party's indemnification obligation unless such failure or delay is materially prejudicial to the Indemnifying Party.

The Indemnifying Party shall have the right to assume the defense thereof with counsel designated by such Indemnifying Party and reasonably satisfactory to the Indemnified Person. If the defendants in any such action include one or more Indemnified Persons and the Indemnifying Party and if the Indemnified Person reasonably concludes that there may be legal defenses available to it and/or other Indemnified Persons which are different from or additional to those available to the Indemnifying Party, the Indemnified Person shall have the right to select separate counsel to assert such legal defenses and to otherwise participate in the defense of such action on its own behalf. In such instances, the Indemnifying Party shall only be required to pay the fees and expenses of one additional attorney to represent an Indemnified Person or Indemnified Persons having such differing or additional legal defenses.

The Indemnified Person shall be entitled, at its expense, to participate in any such action, suit or proceeding, the defense of which has been assumed by the

Indemnifying Party. Notwithstanding the foregoing, the Indemnifying Party (i) shall not be entitled to assume and control the defense of any such action, suit or proceedings if and to the extent that, in the opinion of the Indemnified Person and its counsel, such action, suit or proceeding involves the potential imposition of criminal liability on the Indemnified Person, or there exists a conflict or adversity of interest between the Indemnified Person and the Indemnifying Party, in which event the Indemnifying Party shall pay the reasonable expenses of the Indemnified Person, and (ii) shall not settle or consent to the entry of any judgment in any action, suit or proceeding without the consent of the Indemnified Person, which shall not be reasonably withheld, conditioned or delayed.

- 18.2 Consequential Damages.** Other than the Liquidated Damages heretofore described, in no event shall a Party be liable under any provision of this LGIA for any losses, damages, costs or expenses for any special, indirect, incidental, consequential, or punitive damages, including but not limited to loss of profit or revenue, loss of the use of equipment, cost of capital, cost of temporary equipment or services, whether based in whole or in part in contract, in tort, including negligence, strict liability, or any other theory of liability; provided, however, that damages for which a Party may be liable to the other Party under another agreement will not be considered to be special, indirect, incidental, or consequential damages hereunder.
- 18.3 Insurance.** The Interconnecting Transmission Owner and the Interconnection Customer shall, at their own expense, maintain in force throughout the period of this LGIA, and until released by the other Party(ies), the following minimum insurance coverages, with insurers authorized to do business in the state where the Point of Interconnection is located:
- 18.3.1** Employers' Liability and Workers' Compensation Insurance providing statutory benefits in accordance with the laws and regulations of the state in which the Point of Interconnection is located.
- 18.3.2** Commercial General Liability Insurance including premises and operations, personal injury, broad form property damage, broad form blanket contractual liability coverage (including coverage for the contractual indemnification) products and completed operations coverage, coverage for explosion, collapse and underground hazards, independent contractors coverage, coverage for pollution to the extent normally available and punitive damages to the extent normally available and a cross liability endorsement, with minimum limits of One Million

Dollars (\$1,000,000) per occurrence/One Million Dollars (\$1,000,000) aggregate combined single limit for personal injury, bodily injury, including death, and property damage.

- 18.3.3** Comprehensive Automobile Liability Insurance for coverage of owned and non-owned and hired vehicles, trailers or semi-trailers designed for travel on public roads, with a minimum, combined single limit of One Million Dollars (\$1,000,000) per occurrence for bodily injury, including death, and property damage.
- 18.3.4** Excess Public Liability Insurance over and above the Employers' Liability Commercial General Liability and Comprehensive Automobile Liability Insurance coverage, with a minimum combined single limit of Twenty Million Dollars (\$20,000,000) per occurrence/Twenty Million Dollars (\$20,000,000) aggregate.
- 18.3.5** The Commercial General Liability Insurance, Comprehensive Automobile Insurance and Excess Public Liability Insurance policies shall name the other Party(ies), its parent, associated and Affiliate companies and their respective directors, officers, agents, servants and employees ("Other Party Group") as additional insured. All policies shall contain provisions whereby the insurers waive all rights of subrogation in accordance with the provisions of this LGIA against the Other Party Group and provide thirty (30) Calendar Days advance written notice to the Other Party Group prior to anniversary date of cancellation or any material change in coverage or condition.
- 18.3.6** The Commercial General Liability Insurance, Comprehensive Automobile Liability Insurance and Excess Public Liability Insurance policies shall contain provisions that specify that the policies are primary and shall apply to such extent without consideration for other policies separately carried and shall state that each insured is provided coverage as though a separate policy had been issued to each, except the insurer's liability shall not be increased beyond the amount for which the insurer would have been liable had only one insured been covered. Each Party shall be responsible for its respective deductibles or retentions.
- 18.3.7** The Commercial General Liability Insurance, Comprehensive Automobile Liability Insurance and Excess Public Liability Insurance policies, if written on a Claims First Made Basis, shall be maintained in full force and effect for two (2)

years after termination of this LGIA, which coverage may be in the form of tail coverage or extended reporting period coverage if agreed by the Parties.

- 18.3.8** The requirements contained herein as to the types and limits of all insurance to be maintained by the Parties are not intended to and shall not in any manner, limit or qualify the liabilities and obligations assumed by the Parties under this LGIA.
- 18.3.9** Within ten (10) days following execution of this LGIA, and as soon as practicable after the end of each fiscal year or at the renewal of the insurance policy and in any event within ninety (90) days thereafter, each Party shall provide certification of all insurance required in this LGIA, executed by each insurer or by an authorized representative of each insurer.
- 18.3.10** Notwithstanding the foregoing, each Party may self-insure to meet the minimum insurance requirements of Articles 18.3.2 through 18.3.8 to the extent it maintains a self-insurance program, provided that such Party's senior secured debt is rated at investment grade, or better, by Standard & Poor's and that its self-insurance program meets the minimum insurance requirements of Articles 18.3.2 through 18.3.8. For any period of time that a Party's senior secured debt is unrated by Standard & Poor's or is rated at less than investment grade by Standard & Poor's, such Party shall comply with the insurance requirements applicable to it under Articles 18.3.2 through 18.3.9. In the event that a Party is permitted to self-insure pursuant to this Article, it shall notify the other Party(ies) that it meets the requirements to self-insure and that its self-insurance program meets the minimum insurance requirements in a manner consistent with that specified in Article 18.3.9.
- 18.3.11** The Parties agree to report to each other in writing as soon as practical all accidents or occurrences resulting in injuries to any person, including death, and any property damage arising out of this LGIA.

ARTICLE 19. ASSIGNMENT

- 19.1 Assignment.** This LGIA may be assigned by any Party only with the written consent of the other Parties; provided that the Parties may assign this LGIA without the consent of the other Parties to any Affiliate of the assigning Party with an equal or greater credit rating and with the legal authority and operational ability to satisfy the obligations of the assigning Party under this LGIA; and provided further that the Interconnection Customer

shall have the right to assign this LGIA, without the consent of the Interconnecting Transmission Owner or System Operator, for collateral security purposes to aid in providing financing for the Large Generating Facility, provided that the Interconnection Customer will promptly notify the Interconnecting Transmission Owner and System Operator of any such assignment. Any financing arrangement entered into by the Interconnection Customer pursuant to this Article will provide that prior to or upon the exercise of the secured party's, trustee's or mortgagee's assignment rights pursuant to said arrangement, the secured creditor, the trustee or mortgagee will notify the Interconnecting Transmission Owner and System Operator of the date and particulars of any such exercise of assignment right(s), including providing the Interconnecting Transmission Owner with proof that it meets the requirements of Articles 11.5 and 18.3. Any attempted assignment that violates this Article is void and ineffective. Any assignment under this LGIA shall not relieve a Party of its obligations, nor shall a Party's obligations be enlarged, in whole or in part, by reason thereof. Where required, consent to assignment will not be unreasonably withheld, conditioned or delayed.

ARTICLE 20. SEVERABILITY

- 20.1 Severability.** If any provision in this LGIA is finally determined to be invalid, void or unenforceable by any court or other Governmental Authority having jurisdiction, such determination shall not invalidate, void or make unenforceable any other provision, agreement or covenant of this LGIA; provided that if the Interconnection Customer (or any third party, but only if such third party is not acting at the direction of the Interconnecting Transmission Owner) seeks and obtains such a final determination with respect to any provision of the Alternate Option (Article 5.1.2), or the Negotiated Option (Article 5.1.4), then none of these provisions shall thereafter have any force or effect and the Parties' rights and obligations shall be governed solely by the Standard Option (Article 5.1.1).

ARTICLE 21. COMPARABILITY

- 21.1 Comparability.** The Parties will comply with all applicable comparability and code of conduct laws, rules and regulations, as amended from time to time.

ARTICLE 22. CONFIDENTIALITY

- 22.1 Confidentiality.** Confidential Information shall include, without limitation, all information governed by the ISO New England Information Policy, all information

obtained from third parties under confidentiality agreements, all information relating to a Party's technology, research and development, business affairs, and pricing, and any information supplied by a Party to another prior to the execution of this LGIA.

Information is Confidential Information only if it is clearly designated or marked in writing as confidential on the face of the document, or, if the information is conveyed orally or by inspection, if the Party providing the information orally informs the Party receiving the information that the information is confidential.

If requested by a Party, the other Party(ies) shall provide, in writing, the basis for asserting that the information referred to in this Article warrants confidential treatment, and the requesting Party may disclose such writing to the appropriate Governmental Authority. Each Party shall be responsible for the costs associated with affording confidential treatment to its information.

22.1.1 Term. During the term of this LGIA, and for a period of three (3) years after the expiration or termination of this LGIA, except as otherwise provided in this Article 22, each Party shall hold in confidence and shall not disclose to any person Confidential Information.

22.1.2 Scope. Confidential Information shall not include information that the receiving Party can demonstrate: (1) is generally available to the public other than as a result of a disclosure by the receiving Party; (2) was in the lawful possession of the receiving Party on a non-confidential basis before receiving it from the disclosing Party; (3) was supplied to the receiving Party without restriction by a third party, who, to the knowledge of the receiving Party after due inquiry, was under no obligation to the disclosing Party to keep such information confidential; (4) was independently developed by the receiving Party without reference to Confidential Information of the disclosing Party; (5) is, or becomes, publicly known, through no wrongful act or omission of the receiving Party or Breach of this LGIA; or (6) is required, in accordance with Article 22.1.7 of the LGIA, Order of Disclosure, to be disclosed by any Governmental Authority or is otherwise required to be disclosed by law or subpoena, or is necessary in any legal proceeding establishing rights and obligations under this LGIA. Information designated as Confidential Information will no longer be deemed confidential if the Party that designated the information as confidential notifies the other Party(ies) that it no longer is confidential.

- 22.1.3 Release of Confidential Information.** A Party shall not release or disclose Confidential Information to any other person, except to its Affiliates (limited by the Standards of Conduct requirements), subcontractors, employees, consultants, or to parties who may be or are considering providing financing to or equity participation with Interconnection Customer, or to potential purchasers or assignees of Interconnection Customer, on a need-to-know basis in connection with this LGIA, unless such person has first been advised of the confidentiality provisions of this Article 22 and has agreed to comply with such provisions. Notwithstanding the foregoing, a Party providing Confidential Information to any person shall remain primarily responsible for any release of Confidential Information in contravention of this Article 22.
- 22.1.4 Rights.** Each Party retains all rights, title, and interest in the Confidential Information that each Party discloses to the other Party(ies). The disclosure by each Party to the other Party(ies) of Confidential Information shall not be deemed a waiver by a Party or any other person or entity of the right to protect the Confidential Information from public disclosure.
- 22.1.5 No Warranties.** By providing Confidential Information, a Party does not make any warranties or representations as to its accuracy or completeness. In addition, by supplying Confidential Information, a Party does not obligate itself to provide any particular information or Confidential Information to the other Party(ies) nor to enter into any further agreements or proceed with any other relationship or joint venture.
- 22.1.6 Standard of Care.** Each Party shall use at least the same standard of care to protect Confidential Information it receives as it uses to protect its own Confidential Information from unauthorized disclosure, publication or dissemination. Each Party may use Confidential Information solely to fulfill its obligations to the other Party(ies) under this LGIA or its regulatory requirements.
- 22.1.7 Order of Disclosure.** If a court or a Government Authority or entity with the right, power, and apparent authority to do so requests or requires a Party, by subpoena, oral deposition, interrogatories, requests for production of documents, administrative order, or otherwise, to disclose Confidential Information, that Party shall provide the other Party(ies) with prompt notice of such request(s) or requirement(s) so that the other Party(ies) may seek an appropriate protective order or waive compliance with the terms of this LGIA. Notwithstanding the

absence of a protective order or waiver, the Party may disclose such Confidential Information which, in the opinion of its counsel, the Party is legally compelled to disclose. Each Party will use Reasonable Efforts to obtain reliable assurance that confidential treatment will be accorded any Confidential Information so furnished.

22.1.8 Termination of Agreement. Upon termination of this LGIA for any reason, each Party shall, within ten (10) Calendar Days of receipt of a written request from the other Party(ies), use Reasonable Efforts to destroy, erase, or delete (with such destruction, erasure, and deletion certified in writing to the other Party(ies)) or return to the other Party(ies), without retaining copies thereof, any and all written or electronic Confidential Information received from the other Party(ies).

22.1.9 Remedies. The Parties agree that monetary damages would be inadequate to compensate a Party for the other Party's(ies') Breach of its obligations under this Article 22. Each Party accordingly agrees that the other Party(ies) shall be entitled to equitable relief, by way of injunction or otherwise, if the first Party Breaches or threatens to Breach its obligations under this Article 22, which equitable relief shall be granted without bond or proof of damages, and the receiving Parties shall not plead in defense that there would be an adequate remedy at law. Such remedy shall not be deemed an exclusive remedy for the Breach of this Article 22, but shall be in addition to all other remedies available at law or in equity. The Parties further acknowledge and agree that the covenants contained herein are necessary for the protection of legitimate business interests and are reasonable in scope. No Party, however, shall be liable for indirect, incidental, or consequential or punitive damages of any nature or kind resulting from or arising in connection with this Article 22.

22.1.10 Disclosure to the Commission, its Staff, or a State. Notwithstanding anything in this Article 22 to the contrary, and pursuant to 18 CFR. section 1b.20, if the Commission or its staff, during the course of an investigation or otherwise, requests information from one of the Parties that is otherwise required to be maintained in confidence pursuant to this LGIA, the Party shall provide the requested information to the Commission or its staff, within the time provided for in the request for information. In providing the information to the Commission or its staff, the Party must, consistent with 18 CFR section 388.112, request that the information be treated as confidential and non-public by the Commission and its staff and that the information be withheld from

public disclosure. Parties are prohibited from notifying the other Party(ies) to this LGIA prior to the release of the Confidential Information to the Commission or its staff. The Party shall notify the other Party(ies) to the LGIA when it is notified by the Commission or its staff that a request to release Confidential Information has been received by the Commission, at which time any of the Parties may respond before such information would be made public, pursuant to 18 CFR section 388.112. Requests from a state regulatory body conducting a confidential investigation shall be treated in a similar manner if consistent with the applicable state rules and regulations.

- 22.1.11** Subject to the exception in Article 22.1.10, any information that a Party claims is competitively sensitive, commercial or financial information under this LGIA (“Confidential Information”) shall not be disclosed by the other Party(ies) to any person not employed or retained by the other Party(ies), except to the extent disclosure is (i) required by law; (ii) reasonably deemed by the disclosing Party to be required to be disclosed in connection with a dispute between or among the Parties, or the defense of litigation or dispute; (iii) otherwise permitted by consent of the other Party(ies), such consent not to be unreasonably withheld; or (iv) necessary to fulfill its obligations under this LGIA or as a transmission service provider or a Control Area operator including disclosing the Confidential Information to an RTO or ISO or to a regional or national reliability organization. The Party asserting confidentiality shall notify the other Party(ies) in writing of the information it claims is confidential. Prior to any disclosures of the other Parties’ Confidential Information under this subparagraph, or if any third party or Governmental Authority makes any request or demand for any of the information described in this subparagraph, the disclosing Party agrees to promptly notify the other Party(ies) in writing and agrees to assert confidentiality and cooperate with the other Party(ies) in seeking to protect the Confidential Information from public disclosure by confidentiality agreement, protective order or other reasonable measures.

ARTICLE 23. ENVIRONMENTAL RELEASES

- 23.1** Each Party shall notify the other Party(ies), first orally and then in writing, of the release of any Hazardous Substances, any asbestos or lead abatement activities, or any type of remediation activities related to the Large Generating Facility or the Interconnection Facilities, each of which may reasonably be expected to affect the other Party(ies). The notifying Party shall: (i) provide the notice as soon as practicable, provided such Party

makes a good faith effort to provide the notice no later than twenty-four (24) hours after such Party becomes aware of the occurrence; and (ii) promptly furnish to the other Party(ies) copies of any publicly available reports filed with any Governmental Authorities addressing such events.

ARTICLE 24. INFORMATION REQUIREMENTS

- 24.1 Information Acquisition.** Subject to any applicable confidentiality restrictions, including, but not limited to, codes of conduct, each Party shall submit specific information regarding the electrical characteristics of their respective facilities to each other as described below and in accordance with Applicable Reliability Standards.
- 24.2 Information Submission by System Operator and Interconnecting Transmission Owner.** The initial information submission by System Operator and Interconnecting Transmission Owner shall occur no later than one hundred eighty (180) Calendar Days prior to Trial Operation and shall include information necessary to allow the Interconnection Customer to select equipment and meet any system protection and stability requirements, unless otherwise mutually agreed to by the Parties. On a monthly basis Interconnecting Transmission Owner shall provide Interconnection Customer a status report on the construction and installation of Interconnecting Transmission Owner's Interconnection Facilities and Network Upgrades, including, but not limited to, the following information: (1) progress to date; (2) a description of the activities since the last report; (3) a description of the action items for the next period; and (4) the delivery status of equipment ordered.
- 24.3 Updated Information Submission by Interconnection Customer.** The updated information submission by the Interconnection Customer, including manufacturer information, shall occur no later than one hundred eighty (180) Calendar Days prior to the Trial Operation. Interconnection Customer shall submit a completed copy of the Large Generating Facility data requirements contained in Appendix 1 to the LGIP. It shall also include any additional information provided to Interconnecting Transmission Owner and System Operator for the Interconnection Feasibility Study, Interconnection System Impact Study and Interconnection Facilities Study. Information in this submission shall be the most current Large Generating Facility design or expected performance data. Information submitted for stability models shall be compatible with Interconnecting Transmission Owner and System Operator standard models. If there is no compatible model, the Interconnection Customer will work with a consultant mutually

agreed to by the Parties to develop and supply a standard model and associated information.

If the Interconnection Customer's data is materially different from what was originally provided to Interconnecting Transmission Owner pursuant to the Interconnection Study Agreement between Interconnecting Transmission Owner and Interconnection Customer, then the System Operator will conduct appropriate studies to determine the impact on the New England Transmission System based on the actual data submitted pursuant to this Article 24.3. The Interconnection Customer shall not begin Trial Operation until such studies are completed.

24.4 Information Supplementation. Prior to the Operation Date, the Parties shall supplement their information submissions described above in this Article 24 with any and all "as-built" Large Generating Facility information or "as-tested" performance information that differs from the initial submissions or, alternatively, written confirmation that no such differences exist. The Interconnection Customer shall conduct tests on the Large Generating Facility as required by Good Utility Practice such as an open circuit "step voltage" test on the Large Generating Facility to verify proper operation of the Large Generating Facility's automatic voltage regulator.

Unless otherwise agreed, the test conditions shall include: (1) Large Generating Facility at synchronous speed; (2) automatic voltage regulator on and in voltage control mode; and (3) a five percent change in Large Generating Facility terminal voltage initiated by a change in the voltage regulators reference voltage. Interconnection Customer shall provide validated test recordings showing the responses of Large Generating Facility terminal and field voltages. In the event that direct recordings of these voltages is impractical, recordings of other voltages or currents that mirror the response of the Large Generating Facility's terminal or field voltage are acceptable if information necessary to translate these alternate quantities to actual Large Generating Facility terminal or field voltages is provided. Large Generating Facility testing shall be conducted and results provided to the Interconnecting Transmission Owner for each individual generating unit in a station.

Subsequent to the Operation Date, the Interconnection Customer shall provide Interconnecting Transmission Owner and System Operator any information changes due to equipment replacement, repair, or adjustment. Interconnecting Transmission Owner shall provide the Interconnection Customer any information changes due to equipment replacement, repair or adjustment in the directly connected substation or any adjacent

Interconnecting Transmission Owner-owned substation that may affect the Interconnection Customer's Interconnection Facilities equipment ratings, protection or operating requirements. The Parties shall provide such information no later than thirty (30) Calendar Days after the date of the equipment replacement, repair or adjustment.

ARTICLE 25. INFORMATION ACCESS AND AUDIT RIGHTS

- 25.1 Information Access.** Each Party (the “disclosing Party”) shall make available to the other Parties information that is in the possession of the disclosing Party and is necessary in order for the other Party(ies) to: (i) verify the costs incurred by the disclosing Party for which the other Party(ies) are responsible under this LGIA; and (ii) carry out its obligations and responsibilities under this LGIA. The Parties shall not use such information for purposes other than those set forth in this Article 25.1 and to enforce their rights under this LGIA.
- 25.2 Reporting of Non-Force Majeure Events.** Each Party (the “notifying Party”) shall notify the other Party(ies) when the notifying Party becomes aware of its inability to comply with the provisions of this LGIA for a reason other than a Force Majeure event. The Parties agree to cooperate with each other and provide necessary information regarding such inability to comply, including the date, duration, reason for the inability to comply, and corrective actions taken or planned to be taken with respect to such inability to comply. Notwithstanding the foregoing, notification, cooperation or information provided under this Article shall not entitle the Party receiving such notification to allege a cause for anticipatory breach of this LGIA.
- 25.3 Audit Rights.** Subject to the requirements of confidentiality under Article 22 of this LGIA, each Party shall have the right, during normal business hours, and upon prior reasonable notice to the other Party(ies), to audit at its own expense the other Party's(ies') accounts and records pertaining to a Party's performance or a Party's satisfaction of obligations under this LGIA. Such audit rights shall include audits of the other Party's(ies') costs, calculation of invoiced amounts, the efforts to allocate responsibility for the provision of reactive support to the New England Transmission System, the efforts to allocate responsibility for interruption or reduction of generation on the New England Transmission System, and each Party's actions in an Emergency Condition. Any audit authorized by this Article shall be performed at the offices where such accounts and records are maintained and shall be limited to those portions of such accounts and records that relate to each Party's performance and satisfaction of

obligations under this LGIA. Each Party shall keep such accounts and records for a period equivalent to the audit rights periods described in Article 25.4.

25.4 Audit Rights Periods.

25.4.1 Audit Rights Period for Construction-Related Accounts and Records. Accounts and records related to the design, engineering, procurement, and construction of Interconnecting Transmission Owner's Interconnection Facilities and Network Upgrades shall be subject to audit for a period of twenty-four (24) months following Interconnecting Transmission Owner's issuance of a final invoice in accordance with Article 12.2.

25.4.2 Audit Rights Period for All Other Accounts and Records. Accounts and records related to a Party's performance or satisfaction of all obligations under this LGIA other than those described in Article 25.4.1 shall be subject to audit as follows: (i) for an audit relating to cost obligations, the applicable audit rights period shall be twenty-four (24) months after the auditing Party's receipt of an invoice giving rise to such cost obligations; and (ii) for an audit relating to all other obligations, the applicable audit rights period shall be twenty-four (24) months after the event for which the audit is sought.

25.5 Audit Results. If an audit by a Party determines that an overpayment or an underpayment has occurred, a notice of such overpayment or underpayment shall be given to the other Party(ies) together with those records from the audit which support such determination.

ARTICLE 26. SUBCONTRACTORS

26.1 General. Nothing in this LGIA shall prevent a Party from utilizing the services of any subcontractor as it deems appropriate to perform its obligations under this LGIA; provided, however, that each Party shall require its subcontractors to comply with all applicable terms and conditions of this LGIA in providing such services and each Party shall remain primarily liable to the other Party(ies) for the performance of such subcontractor.

26.2 Responsibility of Principal. The creation of any subcontract relationship shall not relieve the hiring Party of any of its obligations under this LGIA. The hiring Party shall be fully responsible to the other Party(ies) for the acts or omissions of any subcontractor the hiring Party hires as if no subcontract had been made; provided, however, that in no

event shall the Interconnecting Transmission Owner be liable for the actions or inactions of the Interconnection Customer or its subcontractors with respect to obligations of the Interconnection Customer under Article 5 of this LGIA. Any applicable obligation imposed by this LGIA upon the hiring Party shall be equally binding upon, and shall be construed as having application to, any subcontractor of such Party.

26.3 No Limitation by Insurance. The obligations under this Article 26 will not be limited in any way by any limitation of subcontractor's insurance.

ARTICLE 27. DISPUTES

27.1 Submission. In the event a Party has a dispute, or asserts a claim, that arises out of or in connection with this LGIA or its performance, such Party (the "disputing Party") shall provide the other Party(ies) with written notice of the dispute or claim ("Notice of Dispute"). Such dispute or claim shall be referred to a designated senior representative of each Party for resolution on an informal basis as promptly as practicable after receipt of the Notice of Dispute by the other Party(ies). In the event the designated representatives are unable to resolve the claim or dispute through unassisted or assisted negotiations within thirty (30) Calendar Days of the other Party's(ies') receipt of the Notice of Dispute, such claim or dispute may, upon mutual agreement of the Parties, be submitted to arbitration and resolved in accordance with the arbitration procedures set forth below. In the event the Parties do not agree to submit such claim or dispute to arbitration, each Party may exercise whatever rights and remedies it may have in equity or at law consistent with the terms of this LGIA.

27.2 External Arbitration Procedures. Any arbitration initiated under this LGIA shall be conducted before a single neutral arbitrator appointed by the Parties. If the Parties fail to agree upon a single arbitrator within ten (10) Calendar Days of the submission of the dispute to arbitration, each Party shall choose one arbitrator who shall sit on a three-member arbitration panel. The arbitrator so chosen by the System Operator shall chair the arbitration panel. In either case, the arbitrators shall be knowledgeable in electric utility matters, including electric transmission and bulk power issues, and shall not have any current or past substantial business or financial relationships with any party to the arbitration (except prior arbitration). The arbitrator(s) shall provide each of the Parties an opportunity to be heard and, except as otherwise provided herein, shall conduct the arbitration in accordance with the Commercial Arbitration Rules of the American Arbitration Association ("Arbitration Rules") and any applicable Commission regulations

or RTO rules; provided, however, in the event of a conflict between the Arbitration Rules and the terms of this Article 27, the terms of this Article 27 shall prevail.

27.3 Arbitration Decisions. Unless otherwise agreed by the Parties, the arbitrator(s) shall render a decision within ninety (90) Calendar Days of appointment and shall notify the Parties in writing of such decision and the reasons therefore. The arbitrator(s) shall be authorized only to interpret and apply the provisions of this LGIA and shall have no power to modify or change any provision of this Agreement in any manner. The decision of the arbitrator(s) shall be final and binding upon the Parties, and judgment on the award may be entered in any court having jurisdiction. The decision of the arbitrator(s) may be appealed solely on the grounds that the conduct of the arbitrator(s), or the decision itself, violated the standards set forth in the Federal Arbitration Act or the Administrative Dispute Resolution Act. The final decision of the arbitrator must also be filed with the Commission if it affects jurisdictional rates, terms and conditions of service, Interconnection Facilities, or Network Upgrades.

27.4 Costs. Each Party shall be responsible for its own costs incurred during the arbitration process and for the following costs, if applicable: (1) the cost of the arbitrator chosen by the Party to sit on the three member panel; or (2) a pro rata share of the cost of a single arbitrator chosen by the Parties.

ARTICLE 28. REPRESENTATIONS, WARRANTIES AND COVENANTS

28.1 General. Each Party makes the following representations, warranties and covenants:

28.1.1 Good Standing. Such Party is duly organized, validly existing and in good standing under the laws of the state in which it is organized, formed, or incorporated, as applicable; that it is qualified to do business in the state or states in which the Large Generating Facility, Interconnection Facilities and Network Upgrades owned by such Party, as applicable, are located; and that it has the corporate power and authority to own its properties, to carry on its business as now being conducted and to enter into this LGIA and carry out the transactions contemplated hereby and perform and carry out all covenants and obligations on its part to be performed under and pursuant to this LGIA.

28.1.2 Authority. Such Party has the right, power and authority to enter into this LGIA, to become a Party hereto and to perform its obligations hereunder. This LGIA is a legal, valid and binding obligation of such Party, enforceable against such Party

in accordance with its terms, except as the enforceability thereof may be limited by applicable bankruptcy, insolvency, reorganization or other similar laws affecting creditors' rights generally and by general equitable principles (regardless of whether enforceability is sought in a proceeding in equity or at law).

28.1.3 No Conflict. The execution, delivery and performance of this LGIA does not violate or conflict with the organizational or formation documents, or bylaws or operating agreement, of such Party, or any judgment, license, permit, order, material agreement or instrument applicable to or binding upon such Party or any of its assets.

28.1.4 Consent and Approval. Such Party has sought or obtained, or, in accordance with this LGIA will seek or obtain, each consent, approval, authorization, order, or acceptance by any Governmental Authority in connection with the execution, delivery and performance of this LGIA, and it will provide to any Governmental Authority notice of any actions under this LGIA that are required by Applicable Laws and Regulations.

ARTICLE 29. [OMITTED]

ARTICLE 30. MISCELLANEOUS

- 30.1 Binding Effect.** This LGIA and the rights and obligations hereof shall be binding upon and shall inure to the benefit of the successors and assigns of the Parties hereto.
- 30.2 Conflicts.** In the event of a conflict between the body of this LGIA and any attachment, appendices or exhibits hereto, the terms and provisions of the body of this LGIA shall prevail and be deemed the final intent of the Parties.
- 30.3 Rules of Interpretation.** This LGIA, unless a clear contrary intention appears, shall be construed and interpreted as follows: (1) the singular number includes the plural number and vice versa; (2) reference to any person includes such person's successors and assigns but, in the case of a Party, only if such successors and assigns are permitted by this LGIA, and reference to a person in a particular capacity excludes such person in any other capacity or individually; (3) reference to any agreement (including this LGIA), document, instrument or tariff means such agreement, document, instrument, or tariff as amended or modified and in effect from time to time in accordance with the terms thereof and, if applicable, the terms hereof; (4) reference to any Applicable Laws and

Regulations means such Applicable Laws and Regulations as amended, modified, codified, or reenacted, in whole or in part, and in effect from time to time, including, if applicable, rules and regulations promulgated thereunder; (5) unless expressly stated otherwise, reference to any Article, Section or Appendix means such Article of this LGIA or such Appendix to this LGIA, or such Section to the LGIP or such Appendix to the LGIP, as the case may be; (6) “hereunder”, “hereof”, “herein”, “hereto” and words of similar import shall be deemed references to this LGIA as a whole and not to any particular Article or other provision hereof or thereof; (7) “including” (and with correlative meaning “include”) means including without limiting the generality of any description preceding such term; and (8) relative to the determination of any period of time, “from” means “from and including”, “to” means “to but excluding” and “through” means “through and including”.

- 30.4 Entire Agreement.** Except for the ISO New England Operating Documents, Applicable Reliability Standards, or successor documents, this LGIA, including all Appendices and Schedules attached hereto, constitutes the entire agreement between the Parties with reference to the subject matter hereof, and supersedes all prior and contemporaneous understandings or agreements, oral or written, between the Parties with respect to the subject matter of this LGIA. Except for the ISO New England Operating Documents, Applicable Reliability Standards, any applicable tariffs, related facilities agreements, or successor documents, there are no other agreements, representations, warranties, or covenants which constitute any part of the consideration for, or any condition to, any Party’s compliance with its obligations under this LGIA.
- 30.5 No Third Party Beneficiaries.** This LGIA is not intended to and does not create rights, remedies, or benefits of any character whatsoever in favor of any persons, corporations, associations, or entities other than the Parties, and the obligations herein assumed are solely for the use and benefit of the Parties, their successors in interest and, where permitted, their assigns.
- 30.6 Waiver.** The failure of a Party to this LGIA to insist, on any occasion, upon strict performance of any provision of this LGIA will not be considered a waiver of any obligation, right, or duty of, or imposed upon, such Party.
Any waiver at any time by a Party of its rights with respect to this LGIA shall not be deemed a continuing waiver or a waiver with respect to any other failure to comply with any other obligation, right, or duty of this LGIA. Termination or Default of this LGIA for any reason by the Interconnection Customer shall not constitute a waiver of the Interconnection Customer’s legal rights to obtain an interconnection from the

Interconnecting Transmission Owner. Any waiver of this LGIA shall, if requested, be provided in writing.

- 30.7 Headings.** The descriptive headings of the various Articles of this LGIA have been inserted for convenience of reference only and are of no significance in the interpretation or construction of this LGIA.
- 30.8 Multiple Counterparts.** This LGIA may be executed in two or more counterparts, each of which is deemed an original but all constitute one and the same instrument.
- 30.9 Amendment.** The Parties may by mutual agreement amend this LGIA by a written instrument duly executed by the Parties.
- 30.10 Modification by the Parties.** The Parties may by mutual agreement amend the Appendices to this LGIA by a written instrument duly executed by all of the Parties. Such amendment shall become effective and a part of this LGIA upon satisfaction of all Applicable Laws and Regulations.
- 30.11 Reservation of Rights.** Consistent with Section 11.3 of the LGIP, Interconnecting Transmission Owner and System Operator shall have the right to make unilateral filings with the Commission to modify this LGIA with respect to any rates, terms and conditions, charges, classifications of service, rule or regulation under section 205 or any other applicable provision of the Federal Power Act and the Commission's rules and regulations thereunder, and Interconnection Customer shall have the right to make a unilateral filing with the Commission to modify this LGIA pursuant to section 206 or any other applicable provision of the Federal Power Act and the Commission's rules and regulations thereunder; provided that each Party shall have the right to protest any such filing by the other Parties and to participate fully in any proceeding before the Commission in which such modifications may be considered. In the event of disagreement on terms and conditions of the LGIA related to the costs of upgrades to such Interconnecting Transmission Owner's transmission facilities, the anticipated schedule for the construction of such upgrades, any financial obligations of Interconnecting Transmission Owner, and any provisions related to physical impacts of the interconnection on Interconnecting Transmission Owner's transmission facilities or other assets, then the standard applicable under Section 205 of the Federal Power Act shall apply only to Interconnecting Transmission Owner's position on such terms and conditions. Nothing in this LGIA shall limit the rights of the Parties or of the Commission under sections 205 or 206 of the Federal Power Act and the Commission's

rules and regulations thereunder, except to the extent that the Parties otherwise mutually agree as provided herein.

30.12 No Partnership. This LGIA shall not be interpreted or construed to create an association, joint venture, agency relationship, or partnership between the Parties or to impose any partnership obligation or partnership liability upon any Party. No Party shall have any right, power or authority to enter into any agreement or undertaking for, or act on behalf of, or to act as or be an agent or representative of, or to otherwise bind, the other Parties.

IN WITNESS WHEREOF, the Parties have executed this LGIA in triplicate originals, each of which shall constitute and be an original effective Agreement between the Parties.

ISO New England Inc. (System Operator)

By: Richard V. Kowalik
Stephen J. Rourke

Title: Vice President, System Planning

Date: 5/12/10

Public Service Company of New Hampshire, as Interconnection Customer and Interconnecting Transmission Owner

By: _____
Signer's Name

Title: _____

Date: _____

IN WITNESS WHEREOF, the Parties have executed this LGIA in triplicate originals, each of which shall constitute and be an original effective Agreement between the Parties.

ISO New England Inc. (System Operator)

By: _____
Stephen J. Rourke

Title: Vice President, System Planning

Date: _____

Public Service Company of New Hampshire, as Interconnection Customer and Interconnecting Transmission Owner

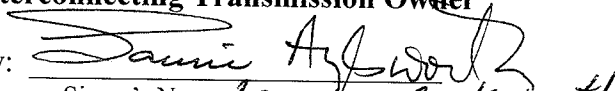
By: 
Signer's Name Laurie Ayksworth

Title: Vice President - Transmission Projects
Engineering and Maintenance

Date: 5-14-10

APPENDICES TO LGIA

- Appendix A Interconnection Facilities, Network Upgrades and Distribution Upgrades
- Appendix B Milestones
- Appendix C Interconnection Details
- Appendix D Security Arrangements Details
- Appendix E Commercial Operation Date
- Appendix F Addresses for Delivery of Notices and Billings
- Appendix G Interconnection Requirements for a Wind Generating Plant

APPENDIX A TO LGIA

Interconnection Facilities, Network Upgrades and Distribution Upgrades

1. Interconnection Facilities:

a. Point of Interconnection and Point of Change of Ownership.

The Point of Interconnection for Merrimack Unit 1 is at the point where 115kV switch G103 connects to 115kV bus 1.

The Point of Interconnection for Merrimack Unit 2 is at the point where 115kV switch G203 connects to 115kV bus 3.

The Point of Interconnection for Merrimack Units CT1 and CT2 is at the point where J134 connects to 115kV bus 1.

The Point of Change of Ownership has been changed to the Point of Change of Function because Public Service Company of New Hampshire, acting as both the Interconnection Customer and Interconnecting Transmission Owner, owns the Interconnection Facilities. While there is no Point of Change of Ownership, there is an operational need to provide a point of demarcation between the facilities that would normally be associated with the Interconnection Customer and those that would normally be associated with the Interconnecting Transmission Owner. The Point of Change of Function demarcates this point. The Point of Change of Function is shown in Appendices A-1 to A-3.

The Point of Change of Function for Merrimack Unit 1 is the jaw side of 115kV switches G103, T2706 and T1706.

The Point of Change of Function for Merrimack Unit 2 is the jaw side of 115kV switches 203, T3206 and T2206.

The Point of Change of Function for Merrimack Units CT1 and CT2 is the jaw side of 115kV switch J134.

The metering point is at each Point of Interconnection.

b. Interconnection Customer’s Interconnection Facilities (including metering equipment).

The Interconnection Customer’s Interconnection Facilities for Merrimack Unit 1 are all equipment from the generator terminals to the Point of Change of Function including the GSU MT1, 115kV switches G101 and 103 and 115kV circuit breaker G1.

The Interconnection Customer’s Interconnection Facilities for Merrimack Unit 2 are all equipment from the generator terminals to the Point of Change of Function including the GSU ST2, 115kV switches G201 and 203 and 115kV circuit breaker G2.

The Interconnection Customer’s Interconnection Facilities for Merrimack Units CT1 are all equipment from the generator terminals to the Point of Change of Function including before the 13.2kV circuit breaker GCT1, GSU MT3 and 115kV switch J134.

The Interconnection Customer’s Interconnection Facilities for Merrimack Units CT2 are all equipment from the generator terminals to the Point of Change of Function including before the 13.2kV circuit breaker GCT2, GSU MT3 and 115kV switch J134.

c. Interconnecting Transmission Owner’s Interconnection Facilities (including metering equipment). None

2. Network Upgrades:

a. Stand-Alone Network Upgrades. None

b. Other Network Upgrades. None

3. Distribution Upgrades: None

4. Affected System Upgrades. None

5. Contingency Upgrades List:

a. Long Lead Facility-Related Upgrades. The Interconnection Customer's Large Generating Facility is associated with a Long Lead Facility, in accordance with Section 3.2.3 of the LGIP. Pursuant to Section 4.1 of the LGIP, the Interconnection Customer shall be responsible for the following upgrades in the event that the Long Lead Facility achieves Commercial Operation and obtains a Capacity Supply Obligation in accordance with Section III.13.1 of the Tariff:

None

If the Interconnection Customer fails to cause these upgrades to be in-service prior to the commencement of the Long Lead Facility's Capacity Commitment Period, the Interconnection Customer shall be deemed to be in Breach of this LGIA in accordance with Article 17.1, and the System Operator will initiate all necessary steps to terminate this LGIA, in accordance with Article 2.3.

b. Other Contingency Upgrades. None

6. Post-Forward Capacity Auction Re-study Upgrade Obligations. To be determined

**APPENDIX A-1: ONE LINE DIAGRAM OF
 MERIMACK STATION 115KV SUBSTATION**

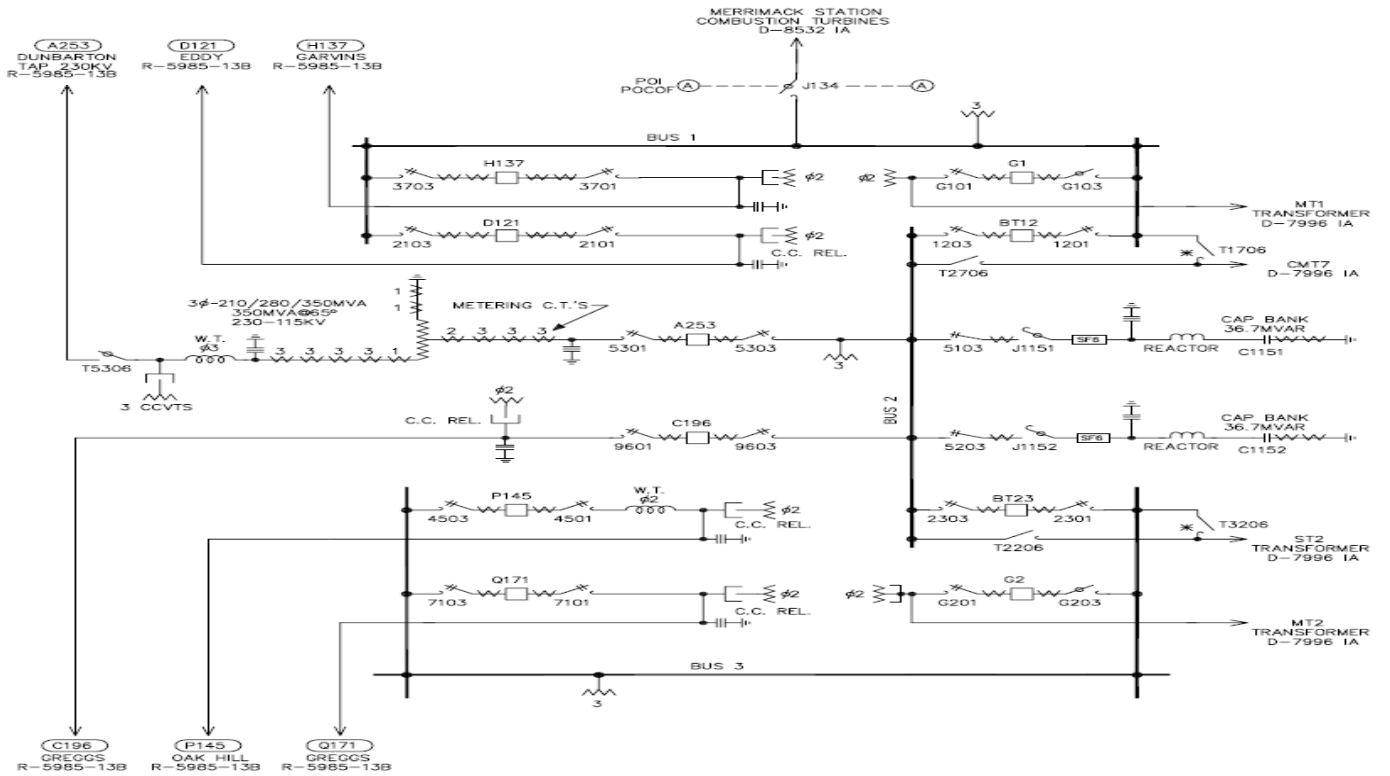

LAST REVISION DETAIL
 Replace LOTO POD with POI/POCO F

POI - POINT OF INTERCONNECTION
 POCO F - POINT OF CHANGE OF FUNCTION

**MERRIMACK STEAM 115KV
 Interconnection Agreement One Line
 224-4081 224-4082**

DRN. CHKD. APPR. 1/13/10 D-8320 IA
 DRM. RJK. DCK. 038129196 IA

APPENDIX A-2: ONE LINE DIAGRAM OF MERRIMACK STATION STEAM PLANT

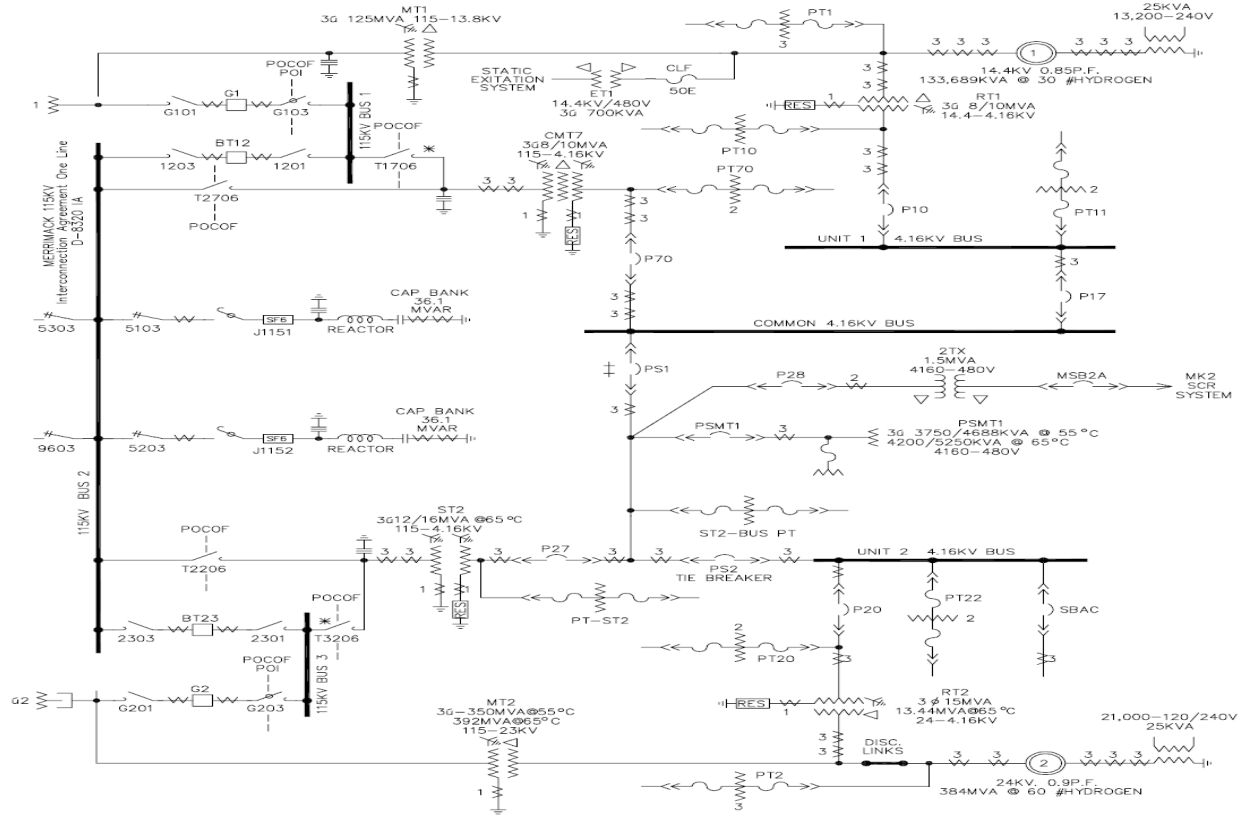

⊥ NORMALLY OPEN
 * NORMALLY OPEN 115KV DIFF. FOR BUSES MUST BE OFF BEFORE CLOSING
 POI - POINT OF INTERCONNECTION
 POCOF - POINT OF CHANGE OF FUNCTION

LAST REVISION DETAIL
 Replace LOTO/POD with POI/POCOF

MERRIMACK STEAM
 Interconnection Agreement One Line

DRN. CHKD. APPR. 1/13/10 D-7996 IA
 JRM. RJF. DCK. 038129195 IA

APPENDIX B TO LGIA

Milestones

1. **Selected Option Pursuant to Article 5.1:** Not applicable. See Appendix C.
2. **Milestones for all Large Generating Facilities:** The description and entries listed in the following table establish the required Milestones in accordance with the provisions of the LGIP and this LGIA.

Item No.	Milestone Description	Responsible Party	Date	LGIP/LGIA Reference
1	Provide evidence of continued Site Control to System Operator, or \$250,000 non-refundable deposit to Interconnecting Transmission Owner	Interconnection Customer	Completed	§ 11.3 of LGIP
2	Provide evidence of one or more milestones specified in § 11.3 of LGIP	Interconnection Customer	Completed	§ 11.3 of LGIP
3A	Commit to a schedule for payment of upgrades	Interconnection Customer	Not Applicable	§ 11.3 of LGIP
3B	Provide either (1) evidence of Major Permits or (2) refundable deposit to Interconnection Transmission Owner	Interconnection Customer	Not Applicable	§ 11.3 of LGIP
4	Provide certificate of insurance	Interconnection Customer and Interconnecting Transmission Owner	Within 10 days of execution of LGIA	§ 18.3.9 of LGIA

5	Provide siting approval for Generating Facility and Interconnection Facilities to Interconnecting Transmission Owner	Interconnection Customer	Not Applicable	§ 7.5 of LGIP
6	Provide written authorization to Interconnecting Transmission Owner to proceed with design, equipment procurement and construction	Interconnection Customer	Not Applicable	§ 5.5.2 and § 5.6.3 of LGIA
7	Engineering of Interconnection Facilities approved by Interconnecting Transmission Owner	Interconnection Customer to provide to Interconnecting Transmission Owner; Interconnecting Transmission Owner to complete approval	Not Applicable	§ 7.5 of LGIP
8	Provision of Security to Interconnecting Transmission Owner pursuant to Section 11.5 of LGIA	Interconnection Customer	Not Applicable	§§ 5.5.3 and 5.6.4 of LGIA
9	Provision of Security to Interconnecting Transmission Owner pursuant to Section 5.17.3 of LGIA	Interconnection Customer	Not Applicable	§ 5.17.3 of LGIA
10	Ordering of long lead time material for Interconnection Facilities and Network Upgrades	Interconnection Customer	Not Applicable	§ 7.5 of LGIP

11A	Provide initial design and specification for Interconnection Customer's Interconnection Facilities to Interconnecting Transmission Owner	Interconnection Customer	Not Applicable	§ 5.10.1 of LGIA
11B	Provide comments on initial design and specification for Interconnection Customer's Interconnection Facilities	Interconnecting Transmission Owner	Not Applicable	§ 5.10.1 of LGIA
12A	Provide final design and specification for Interconnection Customer's Interconnection Facilities to Interconnecting Transmission Owner	Interconnection Customer	Not Applicable	§ 5.10.1 of LGIA
12B	Provide comments on final design and specification for Interconnection Customer's Interconnection Facilities to Interconnecting Transmission Owner	Interconnecting Transmission Owner	Not Applicable	§ 5.10.1 of LGIA
13	Deliver to Transmission Owner "as built" drawings, information and documents regarding Interconnection Customer's Interconnection Facilities	Interconnection Customer	Not Applicable	§ 5.10.3 of LGIA
14	Provide protective relay settings to Interconnecting Transmission Owner for coordination and verification	Interconnection Customer	Not Applicable	§ 5.10.1 of LGIA
15	Commencement of construction of Interconnection Facilities	Interconnecting Transmission Owner	Not Applicable	§ 5.6 of LGIA

16	Deliver to Interconnection Customer “as built” drawings, information and documents regarding Interconnecting Transmission Owner’s Interconnection Facilities	Interconnecting Transmission Owner	Not Applicable	§ 5.11 of LGIA
17	Provide Interconnection Customer final cost invoices	Interconnecting Transmission Owner	Not Applicable	§ 12.2 of LGIA
18	In Service Date	Interconnection Customer	June 1, 2010	§ 3.3.1 and 4.4.5 of LGIP, § 5.1 of LGIA
19	Initial Synchronization Date	Interconnection Customer	June 1, 2010	§ 3.3.1, 4.4.4, 4.4.5, and 7.5 of LGIP
20	Commercial Operation Date	Interconnection Customer	June 1, 2010	§ 3.3.1, 4.4.4, 4.4.5, and 7.5 of LGIP
21	Submit updated information to System Operator and Interconnecting Transmission Owner	Interconnection Customer	January 31, 2010	§ 24.3 of LGIA
22	Submit supplemental and updated information to System Operator and Interconnecting Transmission Owner	Interconnection Customer	Prior to June 1, 2010	§ 24.4 of LGIA
23	Obtain I.3.9 Approval	Interconnection Customer	January 20, 2010	

* The Milestones in this Appendix B correspond to the increase in output for Unit No. 2 of the Large Generating Facility.

3. Milestones Applicable Solely for CNR Interconnection Service and Long Lead Facility Treatment. In addition to the Milestones above, the following Milestones apply to Interconnection Customers requesting CNR Interconnection Service and/or Long Lead Facility Treatment:

Item No.	Milestone Description	Responsible Party	Date	LGIP/LGIA Reference
1	If Long Lead Facility, all dates by which Critical Path Schedule upgrades will be submitted to System Operator (end date for New Capacity Show of Interest Submission)	Interconnection Customer	Not applicable	§ 3.2.3 of LGIP
2	If Long Lead Facility, dates by which Long Lead Facility Deposits will be provided to System Operator (each deadline for which New Generating Capacity Resource would be required to provide financial assurance under § III.13.1.9 of the Tariff)	Interconnection Customer	Not applicable	§ 3.2.3 of LGIP
3	If Long Lead Facility, Capacity Commitment Period (not to exceed the Commercial Operation Date)	Interconnection Customer	Not applicable	§ 1 and 3.2 of LGIP
4	Submit necessary requests for participation in the Forward Capacity Auction associated with the Generating Facility's requested Commercial Operation Date, in accordance with Section III.13 of the Tariff	Interconnection Customer	To be completed	§ 3.2.1.3 of LGIP
5	Participate in a CNR Group Study	Interconnection Customer	To be completed	§ 3.2.1.3 of LGIP
6	Qualify and receive a Capacity Supply Obligation in accordance with Section III.13 of the Tariff	Interconnection Customer	To be completed	§ 3.2.1.3 of LGIP

7	Complete a re-study of the applicable Interconnection Study to determine the cost responsibility for facilities and upgrades necessary to accommodate the Interconnection Request based on the results of the Forward Capacity Auction or Reconfiguration Auction or bilateral transaction through which the Interconnection Customer received a Capacity Supply Obligation	System Operator	To be completed	§ 3.2.1.3 of LGIP
---	---	-----------------	-----------------	-------------------

APPENDIX C TO LGIA

Interconnection Details

1. Description of Interconnection:

Interconnection Customer’s Large Generating Facility consists of a four- (4) unit power plan of 546 MW (winter gross). The Large Generating Facility includes two (2) coal fired steam units and two (2) combustion turbines that are located at Merrimack Station, 97 River Road, Bow, New Hampshire.

The Large Generating Facility shall receive:

Network Resource Interconnection Service for the NR Capability: See Below

Capacity Network Resource Interconnection Service for: (a) (i) the NR Capability at a level not to exceed 514.4 gross MW and 488.9 net MW for Summer and 546 gross MW and 522.23 net MW for Winter; and (ii) the CNR Capability at to be determined MW for Summer and to be determined MW for Winter, which shall not exceed 487.9 MW for Summer and 522.23 MW for Winter.

The Network Resource Interconnection Service for the NR Capability was determined as follows:

Unit	Summer Gross MW at 50°F	Summer Net MW at 50°F	Winter Gross MW at 0°F	Winter Net MW at 0°F
Merrimack 1	123	113.5	131.53	122.73
Merrimack 2	356	340	368.5	353.5
Merrimack CT 1	17.8	17.8	22.5	22.5
Merrimack CT2	17.6	17.6	23.5	23.5
Total	514.4	488.9	546	522.23

The maximum Capacity Network Resource Interconnection Service for the CNR Capability, subject to the completion of the milestones specified in Appendix B.3, was determined as follows:

Unit	Summer Net MW at 90° F	Winter Net MW at 20° F
Merrimack 1	112.5	122.73
Merrimack 2	340	353.5
Merrimack CT 1	17.8	22.5
Merrimack CT2	17.6	23.5
Total	487.9	522.23

The CNR Capability shall be the highest amount of the Capacity Supply Obligation obtained by the Generating Facility in accordance with Section III.13 of the Tariff and, if applicable, as specified in filings by the System Operator with the Commission pursuant to Section III.13 of the Tariff.

2. Detailed Description of Generating Facility and Generator Step-Up Transformer, if applicable:

Merrimack Unit 1:

Generator Data	
Number of Generators	1
Manufacturer	Westinghouse
Model	Hydrogen Cooled
Designation of Generator(s)	NA
Excitation System Manufacturer	Westinghouse
Excitation System Model	P.S. Static Exciter
Voltage Regulator Manufacturer	Westinghouse
Voltage Regulator Model	WTA-300 Type M300
Generator Ratings	
Greatest Unit Gross/Net MW Output at Ambient Temperature of 50 Degrees F or above (summer)	123/113.5
Greatest Unit Gross/Net MW Output at Ambient Temperature of Zero Degrees F or	131.53/122.73

above (winter)	
Station Service Load For Each Unit	Summer- 9.2 MW Winter- 8.3 MW
Overexcited Reactive Power at Rated MVA and Rated Power Factor	70
Underexcited Reactive Power at Rated MVA and Rated Power Factor	-40
Generator Short Circuit Data	
Generator MVA rating	133.689
Generator AC Resistance	0.00174 per unit impedance- own base
Subtransient Reactance (unsaturated)	0.125 per unit impedance- own base
Subtransient Reactance (saturated)	0.115 per unit impedance- own base
Transient Reactance (saturated)	0.187 per unit impedance- own base
Negative sequence resistance	N/A
Negative sequence reactance	0.115 per unit impedance- own base
Transformer Data	
Number of units	1
Self Cooled/Rating (7X)	125 MVA @ 55°C
Maximum Rating	125 MVA @ 55°C
Winding Connection (LV/HV) (7X)	LV= 13.8 Δ, HV= 109.5 Y
Fixed Taps (7X)	N/A
Z1 primary to secondary at self cooled rating (7X)	R1= 0.0028 per unit; X1 = 0.0848 per unit on a 100 MVA Base
Z1 primary to tertiary at self cooled rating (8X)	N/A
Positive Sequence X/R ratio	30.286
Z0 primary to secondary at self cooled rating	R0 = 0.0028 per unit; X0 = 0.0848 per unit on a 100 MVA Base
Zero Sequence X/R ratio	30.286

Merrimack Unit 2:

Generator Data	
Number of Generators	1
Manufacturer	Westinghouse
Model	Hydrogen Inner Cooled

Designation of Generator(s)	N/A
Excitation System Manufacturer	Basler
Excitation System Model	ECS2100
Voltage Regulator Manufacturer	N/A
Voltage Regulator Model	N/A
Generator Ratings	
Greatest Unit Gross/Net MW Output at Ambient Temperature of 50 Degrees F or above (summer)	356/340
Greatest Unit Gross/Net MW Output at Ambient Temperature of Zero Degrees F or above (winter)	368.5/353.5
Station Service Load For Each Unit	14
Overexcited Reactive Power at Rated MVA and Rated Power Factor	170
Underexcited Reactive Power at Rated MVA and Rated Power Factor	-120
Generator Short Circuit Data	
Generator MVA rating	384
Generator AC Resistance	0.00137 per unit impedance- own base
Subtransient Reactance (unsaturated)	0.260 per unit impedance- own base
Subtransient Reactance (saturated)	0.239 per unit impedance- own base
Transient Reactance (unsaturated)	0.325 per unit impedance- own base
Negative sequence resistance	N/A
Negative sequence reactance	0.237 per unit impedance- own base
Transformer Data	
Number of units	1
Self Cooled/Rating (7X)	350 MVA @ 55°C
Maximum Rating	392 MVA @ 65°C
Winding Connection (LV/HV) (7X)	LV= 23 Δ, HV= 115 Y
Fixed Taps (7X)	N/A
Z1 primary to secondary at self cooled rating (7X)	R1 = 0.0007 per unit; X1 = 0.0293 per unit on a 100 MVA Base, winding base

	voltages
Z1 primary to tertiary at self cooled rating (8X)	N/A
Positive Sequence X/R ratio	41.857
Z0 primary to secondary at self cooled rating	R0 = 0.0007 per unit; X0 = 0.0293 per unit on a 100 MVA Base
Zero Sequence X/R ratio	41.857

Merrimack CT1:

Generator Data	
Number of Generators	1
Manufacturer	Electric Machine
Model	Synchronous
Designation of Generator(s)	N/A
Excitation System Manufacturer	N/A
Excitation System Model	N/A
Voltage Regulator Manufacturer	NA
Voltage Regulator Model	N/A
Generator Ratings	
Greatest Unit Gross/Net MW Output at Ambient Temperature of 50 Degrees F or above (summer)	17.8/17.8
Greatest Unit Gross/Net MW Output at Ambient Temperature of Zero Degrees F or above (winter)	22.5/22.5
Station Service Load For Each Unit	Summer- 0.008 MW Winter- 0.016 MW
Overexcited Reactive Power at Rated MVA and Rated Power Factor	11.5
Underexcited Reactive Power at Rated MVA and Rated Power Factor	-6.8
Generator Short Circuit Data	

Generator MVA rating	21.875 MVA
Generator AC Resistance	0.002155 per unit impedance- own base
Subtransient Reactance (unsaturated)	0.14 per unit impedance- own base
Subtransient Reactance (saturated)	0.11 per unit impedance- own base
Transient Reactance (unsaturated)	.23 per unit impedance- own base
Negative sequence resistance	N/A
Negative sequence reactance	.11 per unit impedance- own base
Transformer Data	
Number of units	1
Self Cooled/Rating (7X)	N/A
Maximum Rating	25 kVA
Winding Connection (LV/HV) (7X)	LV= 13.2 Δ, HV= 115 Y
Fixed Taps (7X)	N/A
Z1 primary to secondary at self cooled rating (7X)	R1= 0.0159 per unit; X1 = 0.3877 per unit on a 100 MVA Base, winding base voltages
Z1 primary to tertiary at self cooled rating (8X)	N/A
Positive Sequence X/R ratio	34.384
Z0 primary to secondary at self cooled rating	R0 = 0.0159 per unit; X0 = 0.3877 per unit on a 100 MVA Base
Zero Sequence X/R ratio	34.384

Merrimack CT2:

Generator Data	
Number of Generators	1
Manufacturer	Westinghouse
Model	Open Type Air Cooled
Designation of Generator(s)	N/A
Excitation System Manufacturer	N/A
Excitation System Model	N/A

Voltage Regulator Manufacturer	N/A
Voltage Regulator Model	N/A
Generator Ratings	
Greatest Unit Gross/Net MW Output at Ambient Temperature of 50 Degrees F or above (summer)	17.6/17.6
Greatest Unit Gross/Net MW Output at Ambient Temperature of Zero Degrees F or above (winter)	23.5/23.5
Station Service Load For Each Unit	Summer- 0.008 MW Winter- 0.016 MW
Overexcited Reactive Power at Rated MVA and Rated Power Factor	11.5
Underexcited Reactive Power at Rated MVA and Rated Power Factor	-6.8
Generator Short Circuit Data	
Generator MVA rating	21.378 MVA
Generator AC Resistance	0.002053 per unit impedance- own base
Subtransient Reactance (unsaturated)	0.14 per unit impedance- own base
Subtransient Reactance (saturated)	0.11. per unit impedance- own base
Transient Reactance (unsaturated)	.251 per unit impedance- own base
Negative sequence resistance	N/A
Negative sequence reactance	.134 per unit impedance- own base
Transformer Data	
Number of units	1
Self Cooled/Rating (7X)	N/A
Maximum Rating	125 kVA
Winding Connection (LV/HV) (7X)	LV= 13.2 Δ, HV= 115 Y
Fixed Taps (7X)	N/A
Z1 primary to secondary at self cooled rating (7X)	R1 = 0.0159 per unit; X1 = 0.3877 per unit on a 100 MVA Base
Z1 primary to tertiary at self cooled rating (8X)	N/A

Positive Sequence X/R ratio	34.384
Z0 primary to secondary at self cooled rating	R0= 0.0159 per unit; X0 = 0.3877 per unit on a 100 MVA Base
Zero Sequence X/R ratio	34.384

3. Other Description of Interconnection Plan and Facilities:

Operations & Maintenance Charges:

There are no Interconnecting Transmission Owner's Interconnection Facilities being installed or upgraded at this time, and there are also no Network or Distribution Upgrades. Therefore, there shall not be any O&M charges applicable to the Interconnection Customer. In the future, any applicable capital improvements shall be recognized and accorded treatment pursuant to Schedule 11 of Section II of the Tariff, the LGIP, and Articles 10.2 and 11.4.1 of this Agreement and such Generator Interconnection Related Upgrades ("GIRU") shall be paid for through the assessment of an annual facilities charge.

APPENDIX D TO LGIA

Security Arrangements Details

Infrastructure security of the New England Transmission System equipment and operations and control hardware and software is essential to ensure day-to-day New England Transmission System reliability and operational security. The Commission will expect System Operator, Interconnecting Transmission Owners, market participants, and Interconnection Customers interconnected to the New England Transmission System to comply with the recommendations offered by the President's Critical Infrastructure Protection Board and, eventually, best practice recommendations from the electric reliability authority. All public utilities will be expected to meet basic standards for system infrastructure and operational security, including physical, operational, and cyber-security practices.

APPENDIX E TO LGIA

Commercial Operation Date

This Appendix E is a part of the LGIA between System Operator Interconnecting Transmission Owner and Interconnection Customer.

[Date]

Public Service Company of New Hampshire
C/O Northeast Utilities Service Company, Inc.
107 Selden Street
Berlin, CT 06037
Attention: William O'Hara, Program Manager - Interconnection & Services

With Copy to:
Public Service Company of New Hampshire
Mr. John MacDonald, VP Energy Delivery & Generation
780 North Commercial Street, Energy Park – 3
Manchester, NH 03101

David Forrest – Generator Interconnections
Transmission Planning Department
ISO New England Inc.
One Sullivan Road
Holyoke, MA 01040-2841

Re: Merrimack Large Generating Facility

Dear _____:

On [Date] [Interconnection Customer] has completed Trial Operation of Unit No. _____. This letter confirms that [Interconnection Customer] commenced commercial operation of Unit No. _____ at the Large Generating Facility, effective as of [Date plus one day].

Thank you.

[Signature]

[Interconnection Customer Representative]

APPENDIX F TO LGIA

Addresses for Delivery of Notices and Billings Notices:

System Operator:

Generator Interconnections
Transmission Planning Department
ISO New England Inc.
One Sullivan Road
Holyoke, MA01040-2841

With copy to:
Billing Department
ISO New England Inc.
One Sullivan Road
Holyoke, MA 01040-2841

Interconnecting Transmission Owner and Interconnection Customer:

Public Service Company of New Hampshire
C/O Northeast Utilities Service Company, Inc.
107 Selden Street
Berlin, CT 06037
Attention: William O'Hara, Program Manager - Transmission Interconnection & Services

With copy to:

Legal Department
Northeast Utilities Services Company
P.O. Box 270
Hartford, CT 06141-0270
Attention: General Counsel

and

Public Service Company of New Hampshire
Mr. John MacDonald, VP Energy Delivery & Generation
780 North Commercial Street, Energy Park – 3
Manchester, NH 03101

Billings and Payments:

System Operator:

Generator Interconnections
Transmission Planning Department
ISO New England Inc.
One Sullivan Road
Holyoke, MA 01040-2841

With copy to:

Billing Department
ISO New England Inc.
One Sullivan Road
Holyoke, MA 01040-2841

Interconnecting Transmission Owner and Interconnection Customer:

Public Service Company of New Hampshire
C/O Northeast Utilities Service Company, Inc.
107 Selden Street
Berlin, CT 06037
Attention: William O'Hara, Program Manager - Transmission Interconnection & Services

Public Service Company of New Hampshire
Mr. John MacDonald, VP Energy Delivery & Generation
780 North Commercial Street, Energy Park – 3
Manchester, NH 03101

Alternative Forms of Delivery of Notices (telephone, facsimile or email):

System Operator:

Facsimile: (413) 540-4203
E-mail: geninterconn@iso-ne.com

With copy to:

Facsimile: (413) 535-4024
E-mail: billingdepartment@iso-ne.com

Interconnecting Transmission Owner and Interconnection Customer:

Telephone: (860) 665-2925
Facsimile: (860) 665-6550
Email: oharaw@nu.com

DUNS Numbers:

Interconnection Customer and Interconnecting Transmission Owner: **006971352**

APPENDIX G TO LGIA

Interconnection Requirements For A Wind Generating Plant

Appendix G sets forth requirements and provisions specific to a wind generating plant.

All other requirements of this LGIA continue to apply to wind generating plant interconnections.

A. Technical Standards Applicable to a Wind Generating Plant

i. Low Voltage Ride-Through (LVRT) Capability

A wind generating plant shall be able to remain online during voltage disturbances up to the time periods and associated voltage levels set forth in the standard below. The LVRT standard provides for a transition period standard and a post-transition period standard.

Transition Period LVRT Standard

The transition period standard applies to wind generating plants subject to FERC Order 661 that have either: (i) interconnection agreements signed and filed with the Commission, filed with the Commission in unexecuted form, or filed with the Commission as non-conforming agreements between January 1, 2006 and December 31, 2006, with a scheduled in-service date no later than December 31, 2007, or (ii) wind generating turbines subject to a wind turbine procurement contract executed prior to December 31, 2005, for delivery through 2007.

1. Wind generating plants are required to remain in-service during three-phase faults with normal clearing (which is a time period of approximately 4 – 9 cycles) and single line to ground faults with delayed clearing, and subsequent post-fault voltage recovery to prefault voltage unless clearing the fault effectively disconnects the generator from the system. The clearing time requirement for a three-phase fault will be specific to the wind generating plant substation location, as determined by and documented by the System Operator and Interconnecting Transmission Owner. The maximum clearing time the wind generating plant

shall be required to withstand for a three-phase fault shall be 9 cycles at a voltage as low as 0.15 p.u., as measured at the high side of the wind generating plant step-up transformer (i.e. the transformer that steps the voltage up to the transmission interconnection voltage or “GSU”), after which, if the fault remains following the location-specific normal clearing time for three-phase faults, the wind generating plant may disconnect from the transmission system.

2. This requirement does not apply to faults that would occur between the wind generator terminals and the high side of the GSU or to faults that would result in a voltage lower than 0.15 per unit on the high side of the GSU serving the facility.
3. Wind generating plants may be tripped after the fault period if this action is intended as part of a special protection system.
4. Wind generating plants may meet the LVRT requirements of this standard by the performance of the generators or by installing additional equipment (e.g., Static VAr Compensator, etc.) within the wind generating plant or by a combination of generator performance and additional equipment.
5. Existing individual wind generator units that are, or have been, interconnected to the network at the same location at the effective date of the Appendix G LVRT Standard are exempt from meeting the Appendix G LVRT Standard for the remaining life of the existing generation equipment. Existing individual wind generator units that are replaced are required to meet the Appendix G LVRT Standard.

Post-transition Period LVRT Standard

All wind generating plants subject to FERC Order No. 661 and not covered by the transition period described above must meet the following requirements:

1. Wind generating plants are required to remain in-service during three-phase faults with normal clearing (which is a time period of approximately 4 – 9 cycles) and single line to ground faults with delayed clearing, and subsequent post-fault voltage recovery to prefault voltage unless clearing the fault effectively disconnects the generator from the system. The clearing time requirement for a three-phase fault will be specific to the wind generating plant substation location, as determined by and documented by the System Operator and Interconnecting Transmission Owner. The maximum clearing time the wind generating plant shall be required to withstand for a three-phase fault shall be 9 cycles after which, if the fault remains following the location-specific normal clearing time for three-

phase faults, the wind generating plant may disconnect from the transmission system. A wind generating plant shall remain interconnected during such a fault on the transmission system for a voltage level as low as zero volts, as measured at the high voltage side of the wind GSU.

2. This requirement does not apply to faults that would occur between the wind generator terminals and the high side of the GSU.
3. Wind generating plants may be tripped after the fault period if this action is intended as part of a special protection system.
4. Wind generating plants may meet the LVRT requirements of this standard by the performance of the generators or by installing additional equipment (e.g., Static VAr Compensator) within the wind generating plant or by a combination of generator performance and additional equipment.
5. Existing individual wind generator units that are, or have been, interconnected to the network at the same location at the effective date of the Appendix G LVRT Standard are exempt from meeting the Appendix G LVRT Standard for the remaining life of the existing generation equipment. Existing individual wind generator units that are replaced are required to meet the Appendix G LVRT Standard.

ii. Power Factor Design Criteria (Reactive Power)

A wind generating plant shall maintain a power factor within the range of 0.95 leading to 0.95 lagging, measured at the Point of Interconnection as defined in this LGIA, if the Interconnection System Impact Study shows that such a requirement is necessary to ensure safety or reliability. The power factor range standard can be met by using, for example, power electronics designed to supply this level of reactive capability (taking into account any limitations due to voltage level, real power output, etc.) or fixed and switched capacitors if agreed to by the System Operator and Interconnecting Transmission Owner, or a combination of the two. The Interconnection Customer shall not disable power factor equipment while the wind generating plant is in operation. Wind generating plants shall also be able to provide sufficient dynamic voltage support in lieu of the power system stabilizer and automatic voltage regulation

at the generator excitation system if the Interconnection System Impact Study shows this to be required for system safety or reliability.

iii. Supervisory Control and Data Acquisition (SCADA) Capability

The wind generating plant shall provide SCADA capability to transmit data and receive instructions from the System Operator and Local Control Center to protect system reliability. The System Operator, Interconnecting Transmission Owner and the wind generating plant Interconnection Customer shall determine what SCADA information is essential for the proposed wind generating plant, taking into account the size of the plant and its characteristics, location, and importance in maintaining generation resource adequacy and transmission system reliability in its area.

Attachment 2

THIS STANDARD LARGE GENERATOR INTERCONNECTION AGREEMENT (“Agreement”) is made and entered into this 17th day of May 2010, by and between _____, a Public Service Company of New Hampshire, a public service company organized and existing under the laws of the State/Commonwealth of _____ (of New Hampshire, (herein known as both “Interconnection Customer” with a Large Generating Facility), and “Interconnecting Transmission Owner”) and ISO New England Inc., a non-stock corporation organized and existing under the laws of the State of Delaware (“System Operator”), and _____, a _____ organized and existing under the laws of the State/Commonwealth of _____ (“Interconnecting Transmission Owner”). Under this Agreement the Interconnection Customer, System Operator, and Interconnecting Transmission Owner each may be referred to as a “Party” or collectively as the “Parties.”

RECITALS

WHEREAS, System Operator is the central dispatching agency provided for under the Transmission Operating Agreement (“TOA”) which has responsibility for the operation of the New England Control Area from the System Operator control center and the administration of the Tariff; and

WHEREAS, Interconnecting Transmission Owner is the owner or possessor of an interest in the Administered Transmission System; and

WHEREAS, Interconnection Customer intends to own, lease and/or control and operate the Generating Facility identified as a Large Generating Facility in Appendix C to this Agreement; and

WHEREAS, System Operator, and Public Service Company of New Hampshire as both Interconnection Customer and Interconnecting Transmission Owner have agreed to enter into this Agreement for the purpose of interconnecting the Large Generating Facility to the Administered Transmission System.

NOW, THEREFORE, in consideration of and subject to the mutual covenants contained herein, it is agreed:

When used in this Standard Large Generator Interconnection Agreement, terms with initial capitalization that are not defined in Article 1 shall have the meanings specified in the Article in which they are used.

Governmental Authority shall mean any federal, state, local or other governmental regulatory or administrative agency, court, commission, department, board, or other governmental subdivision, legislature, rulemaking board, tribunal, or other governmental authority having jurisdiction over the Parties, their respective facilities, or the respective services they provide, and exercising or entitled to exercise any administrative, executive, police, or taxing authority or power; provided, however, that such term does not include the System Operator, Interconnection Customer, Interconnecting Transmission Owner, or any Affiliate thereof.

Hazardous Substances shall mean any chemicals, materials or substances defined as or included in the definition of “hazardous substances,” “hazardous wastes,” “hazardous materials,” “hazardous constituents,” “restricted hazardous materials,” “extremely hazardous substances,” “toxic substances,” “radioactive substances,” “contaminants,” “pollutants,” “toxic pollutants” or words of similar meaning and regulatory effect under any applicable Environmental Law, or any other chemical, material or substance, exposure to which is prohibited, limited or regulated by any applicable Environmental Law.

Initial Synchronization Date shall mean the date upon which the Generating Facility is initially synchronized and upon which Trial Operation begins.

In-Service Date shall mean the date upon which the Interconnection Customer reasonably expects it will be ready to begin use of the Interconnecting Transmission Owner’s Interconnection Facilities to obtain back feed power.

Interconnecting Transmission Owner shall mean a Transmission Owner that owns, leases or otherwise possesses an interest in the portion of the Administered Transmission System at the Point of Interconnection and shall be a Party to the Standard Large Generator Interconnection Agreement. The term Interconnecting Transmission Owner shall not be read to include the System Operator.

Interconnecting Transmission Owner’s Interconnection Facilities shall mean all facilities and equipment owned, controlled, or operated by Interconnecting Transmission Owner from the Point of Change of Ownership-Function to the Point of Interconnection as identified in Appendix A to the Standard Large Generator Interconnection Agreement, including any modifications, additions or upgrades to such facilities and equipment. Interconnecting Transmission Owner’s Interconnection Facilities are sole use facilities and shall not include Distribution Upgrades, Stand Alone Network Upgrades or Network Upgrades.

Interconnection Customer shall mean any entity, including a transmission owner or its Affiliates or subsidiaries, that proposes to interconnect its Generating Facility with the Administered Transmission System.

Interconnection Customer's Interconnection Facilities shall mean all facilities and equipment, as identified in Appendix A of the Standard Large Generator Interconnection Agreement, that are located between the Generating Facility and the Point of Change of Ownership Function, including any modification, addition, or upgrades to such facilities and equipment necessary to physically and electrically interconnect the Generating Facility to the Administered Transmission System. Interconnection Customer's Interconnection Facilities are sole use facilities.

Interconnection Facilities shall mean the Interconnecting Transmission Owner's Interconnection Facilities and the Interconnection Customer's Interconnection Facilities. Collectively, Interconnection Facilities include all facilities and equipment between the Generating Facility and the Point of Interconnection, including any modification, additions or upgrades that are necessary to physically and electrically interconnect the Generating Facility to the Administered Transmission System. Interconnection Facilities are sole use facilities and shall not include Distribution Upgrades, Stand Alone Network Upgrades or Network Upgrades.

Interconnection Facilities Study shall mean a study conducted by the System Operator, Interconnecting Transmission Owner, or a third party consultant for the Interconnection Customer to determine a list of facilities (including Interconnecting Transmission Owner's Interconnection Facilities and Network Upgrades as identified in the Interconnection System Impact Study), the cost of those facilities, and the time required to interconnect the Generating Facility with the Administered Transmission System. The scope of the study is defined in Section 8 of the Standard Large Generator Interconnection Procedures.

Interconnection Facilities Study Agreement shall mean the form of agreement contained in Appendix 4 of the Standard Large Generator Interconnection Procedures for conducting the Interconnection Facilities Study.

Interconnection Feasibility Study shall mean a preliminary evaluation of the system impact and cost of interconnecting the Generating Facility to the Administered Transmission System, the scope of which is described in Section 6 of the Standard Large Generator Interconnection Procedures. The Interconnection Customer has the option to request either that the Interconnection Feasibility Study be completed as a separate and distinct study, or as part of the Interconnection System Impact Study. If the Interconnection Customer requests that the

Network Resource Capability (“NR Capability”) shall mean the maximum gross and net megawatt electrical output of the Generating Facility at an ambient temperature at or above 50 degrees F. for Summer and at or above 0 degrees F. for Winter. Where the Generating Facility includes multiple energy production devices, the NR Capability shall be the aggregate maximum gross and net megawatt electrical output of the Generating Facility at an ambient temperature at or above 50 degrees F. for Summer and at or above 0 degrees F. for Winter. NR Capability shall be equal to or greater than the CNR Capability.

Network Resource Interconnection Service (“NR Interconnection Service”) shall mean the Interconnection Service selected by the Interconnection Customer to interconnect its Generating Facility to the Administered Transmission System in accordance with the Network Capability Interconnection Standard. An Interconnection Customer’s NR Interconnection Service shall be solely for the megawatt amount of the NR Capability. NR Interconnection Service in and of itself does not convey transmission service.

Network Upgrades shall mean the additions, modifications, and upgrades to the New England Transmission System required at or beyond the Point of Interconnection to accommodate the interconnection of the Large Generating Facility to the Administered Transmission System.

Notice of Dispute shall mean a written notice of a dispute or claim that arises out of or in connection with the Standard Large Generator Interconnection Agreement or its performance.

Optional Interconnection Study shall mean a sensitivity analysis based on assumptions specified by the Interconnection Customer in the Optional Interconnection Study Agreement.

Optional Interconnection Study Agreement shall mean the form of agreement contained in Appendix 5 of the Standard Large Generator Interconnection Procedures for conducting the Optional Interconnection Study.

Party or Parties shall mean the System Operator, Interconnection Customer and Interconnecting Transmission Owner or any combination of the above.

Point of Change of Ownership-Function shall mean the point, as set forth in Appendix A to the Standard Large Generator Interconnection Agreement, where the Interconnection Customer’s Interconnection Facilities connect to Interconnecting Transmission Owner’s Interconnection Facilities.

IN WITNESS WHEREOF, the Parties have executed this LGIA in triplicate originals, each of which shall constitute and be an original effective Agreement between the Parties.

ISO New England Inc. (System Operator)

By: _____
 Stephen J. Rourke

Title: Vice President, System Planning

Date: _____

~~[Insert Name of] (Public Service Company of New Hampshire, as Interconnection Customer and Interconnecting Transmission Owner)~~

By: By: _____
 Title: Signer's Name

Date: Title: _____

~~[Insert name of] (Interconnection Customer)~~ Date: _____

By:

Attachment 3

ATTACHMENT 3

**REVISED TARIFF SHEET TO ORIGINAL SERVICE AGREEMENT NO. LGIA-
ISONE/NU/08-06 UNDER THE ISO TARIFF**

NOTICE OF CANCELLATION

CANCELS

ORIGINAL SERVICE AGREEMENT NO. LGIA-ISON/NU/08-06

ISO NEW ENGLAND INC.

**(Originally filed under Schedule 22 of the ISO New England Inc.'s
Transmission, Markets and Services Tariff,
FERC Electric Tariff No. 3)**