

Training Disclaimer: ISO New England (ISO) provides training to enhance participant and stakeholder understanding. Not all issues and requirements are addressed by the training. Consult the effective [Transmission, Markets and Services Tariff](#) and the relevant [Market Manuals](#), [Operating Procedures](#) and [Planning Procedures](#) for detailed information. In case of a discrepancy between training provided by ISO and the Tariff or Procedures, the meaning of the Tariff and Procedures shall govern.

Locational Marginal Pricing

Intermediate Wholesale Electricity Markets (IWEM)



Slides containing quiz questions or classroom exercises are hidden in the printed and posted versions of this presentation.

Jinye “Jeannie” Zhao

Technical Manager, Advanced Technologies Solutions



Objectives

At the end of this presentation you will be able to:

- Identify the marginal resource
- Calculate locational marginal price (LMP)
- Determine the effect of transmission constraints on the LMP
- Recognize why the price is different at different locations
- Recognize possible causes of extreme LMPs



Topics

- LMP Basics
- Economic principles of economic dispatch
- Marginal Resource and LMP
- Calculating LMPs
- Impact of Transmission Line Impedance on LMPs
- Bidding Decisions and Possible Impacts



LMP Basics



Day-Ahead and Real-Time LMPs

- Why aren't LMPs the same at all locations?
- What can cause LMPs to diverge?
- How can we calculate the LMPs?

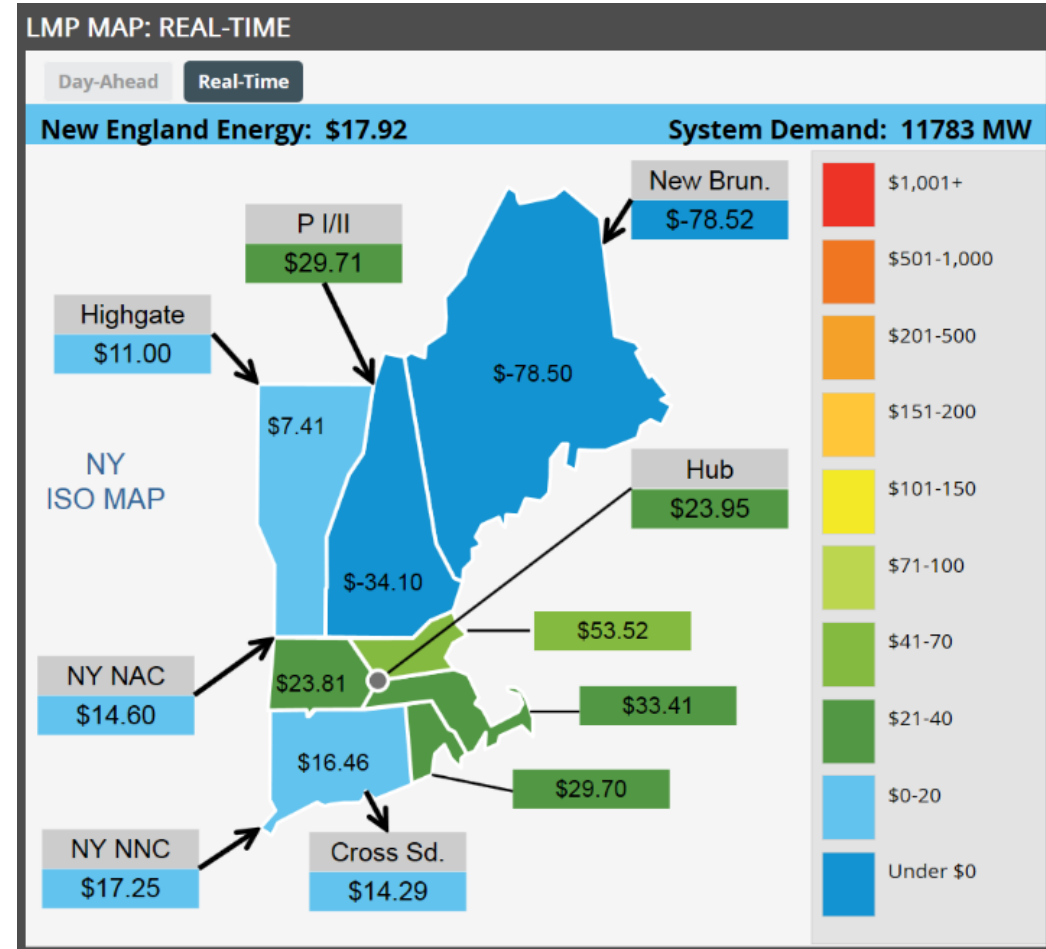

October 30, 2017 @ 08:36

LMPs establish prices for energy purchases and sales at specific locations throughout the New England wholesale electricity market

Pay generators (suppliers)

Charge load (consumers)



Determine compensation
for FTR holders

Collect transmission
congestion charges

LMP Locations

Node

Point on the transmission system for which nodal prices are calculated

Load Zone

- Aggregation of nodes
- 8 load zones in New England
- Same boundaries as reliability regions
- MA has three load zones

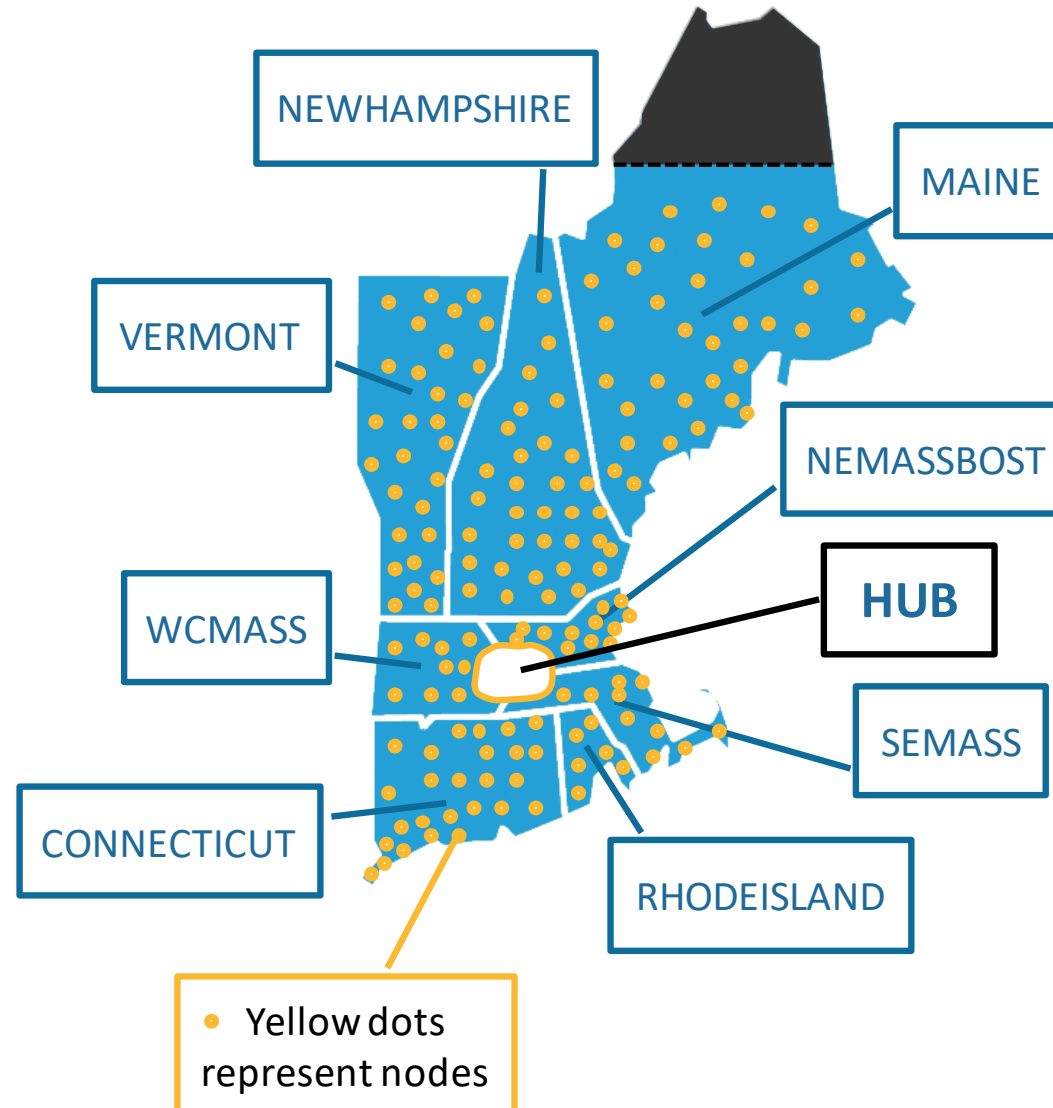

Hub

- Set of nodes for which LMP is calculated
- Reference point for FTRs
- Consists of 32 nodes

External Node *(not shown)*

- Proxy location on transmission system
- Establishes prices for power sold to or bought from outside NE

Price Determination

Load Zone

Zonal price is the **load-weighted average** of the prices of all nodes inside a load zone

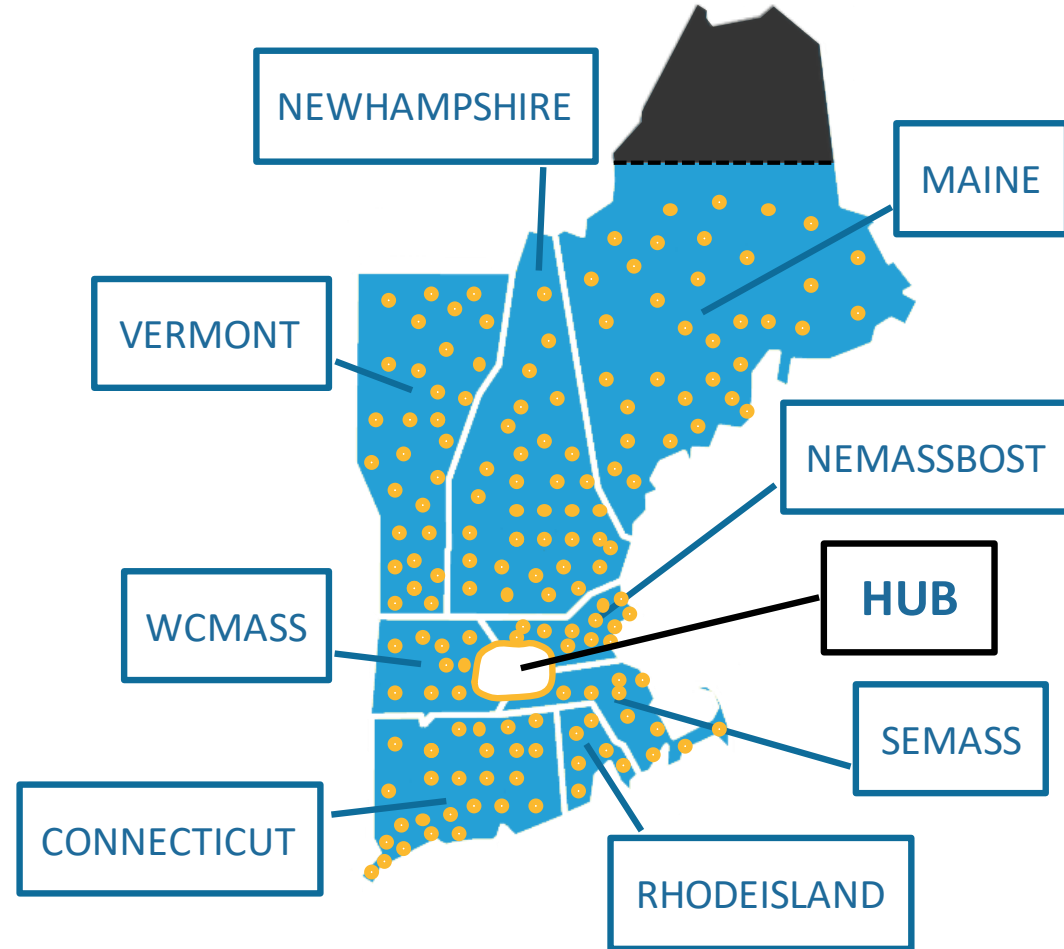

Hub

Hub price is a **simple average** of LMPs at locations within the hub footprint

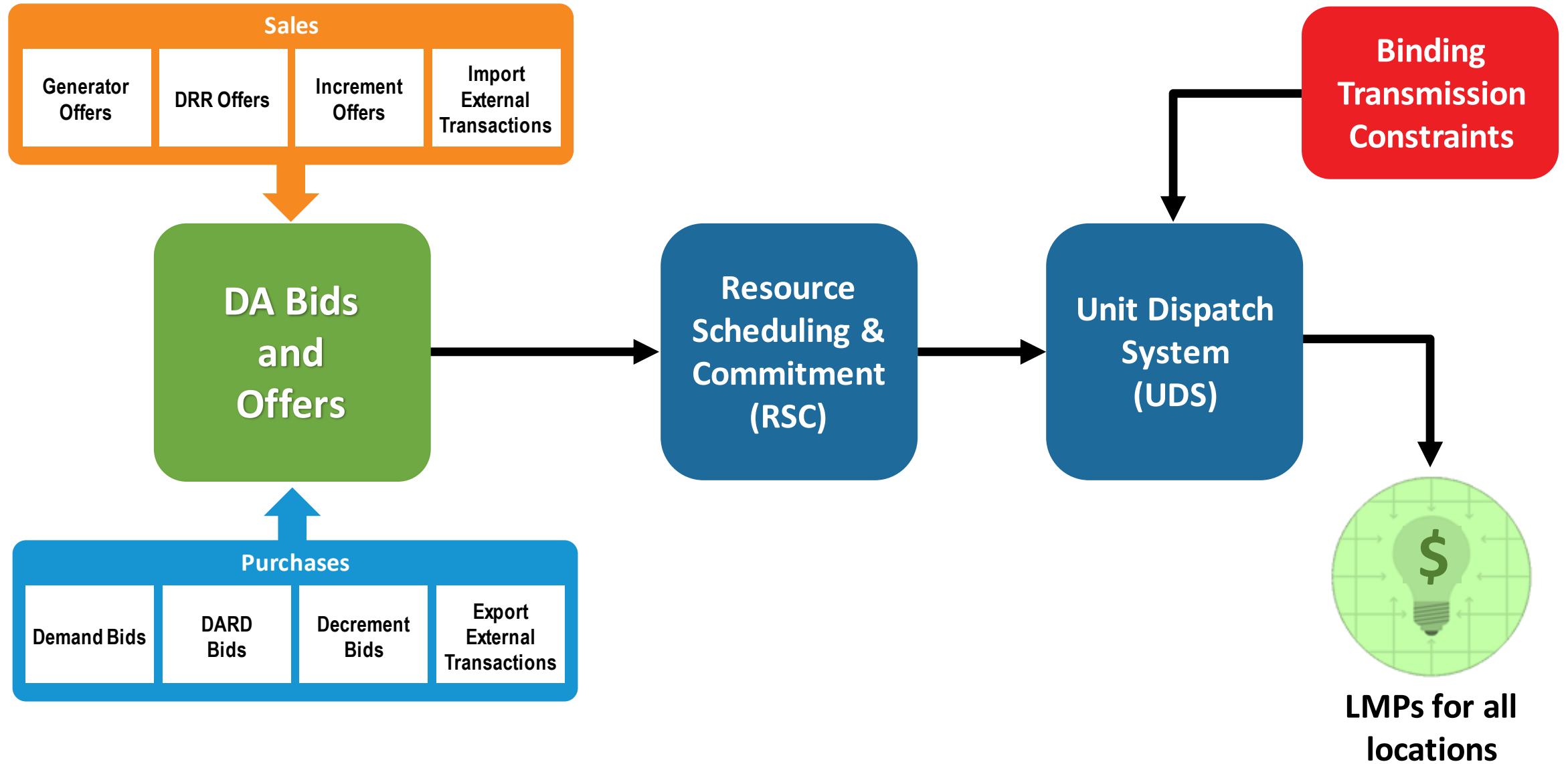

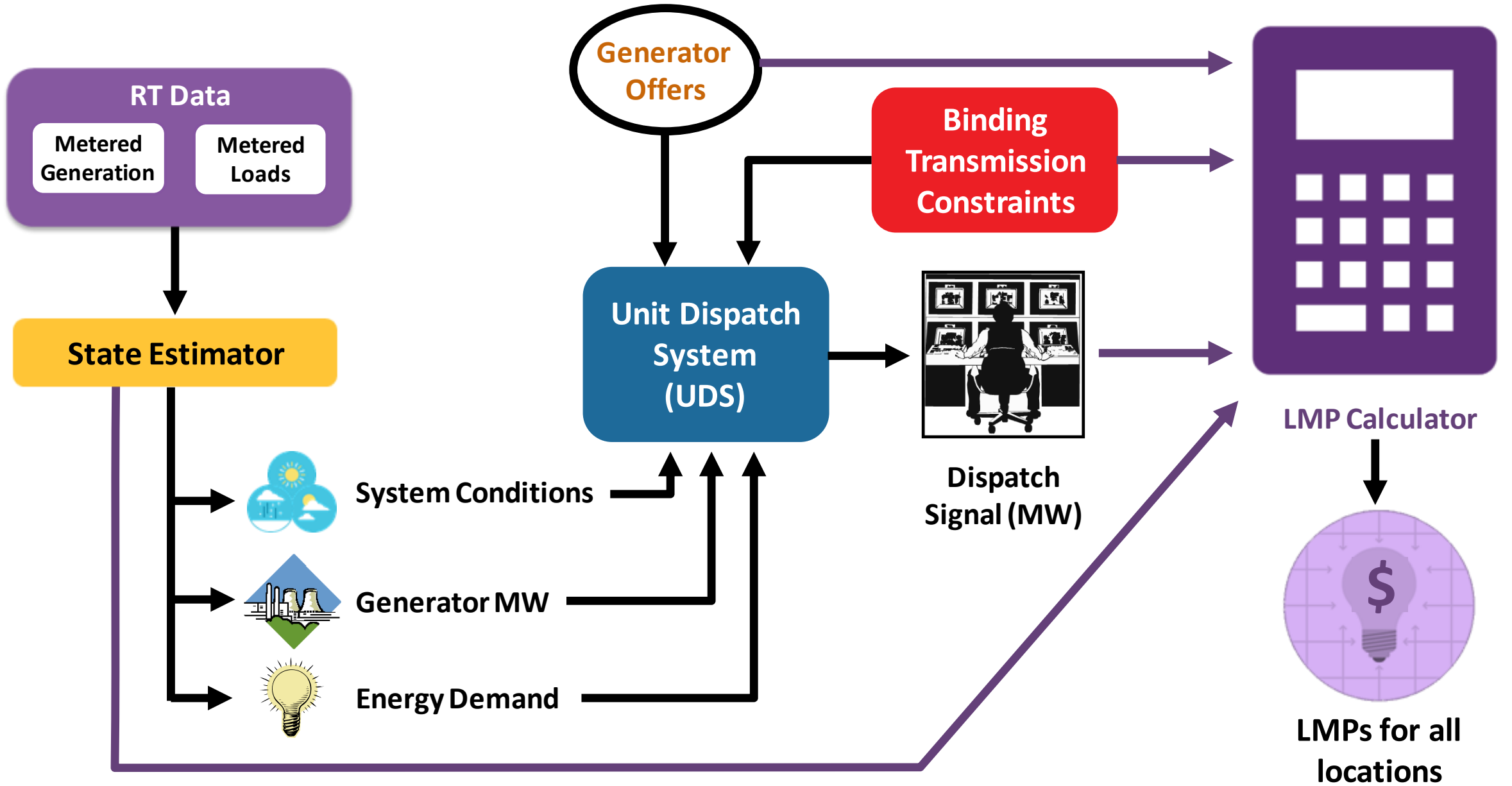

Power System Normal Operation Control

Objective: Maintain Balance Between Supply and Demand

Processes under normal operations



**Automatic
Generation
Control (AGC)**

*At any moment, the sum of all
generation must meet all loads, losses
and scheduled net interchange*



Load Following

Economic Dispatch

Focus of this section

Dispatching Resources

Dispatch

- Changing resource MW output to balance supply and demand
- There are many ways to balance the system depending on the objective

Economic Dispatch

- Part of the load-following control
- Runs approximately every 10 minutes
- Re-optimizes generation to meet load at minimum cost
- Results in desired dispatch points (DDP) in megawatts (MW)
- Calculates LMPs at each generator node
- Economic-merit order

Economic Dispatch

Least expensive way of supplying load in the system

Economic Principles of Economic Dispatch

Economic Dispatch with Price-Sensitive Demand

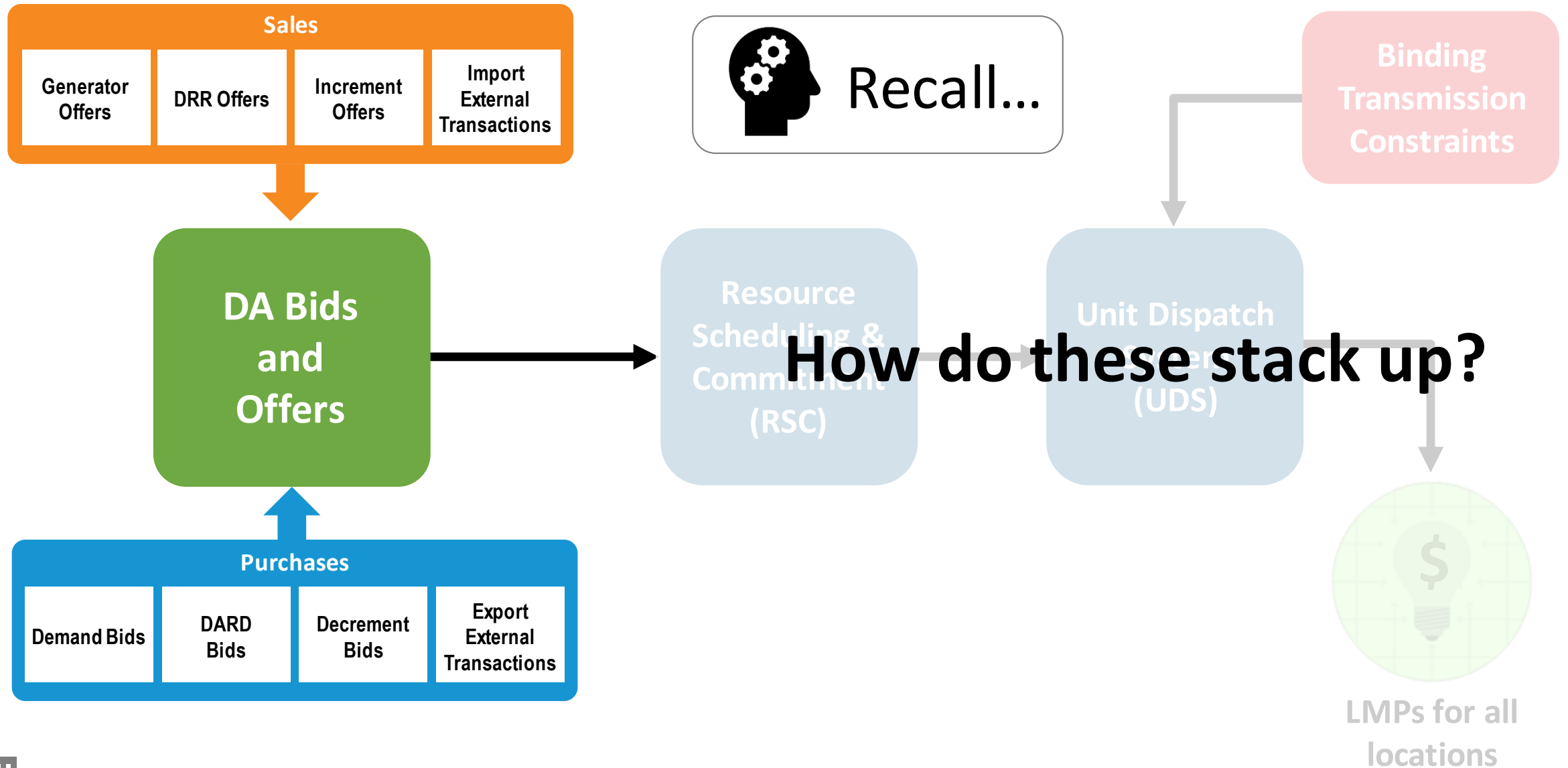

Economic Dispatch and Markets with Price-Sensitive Demand

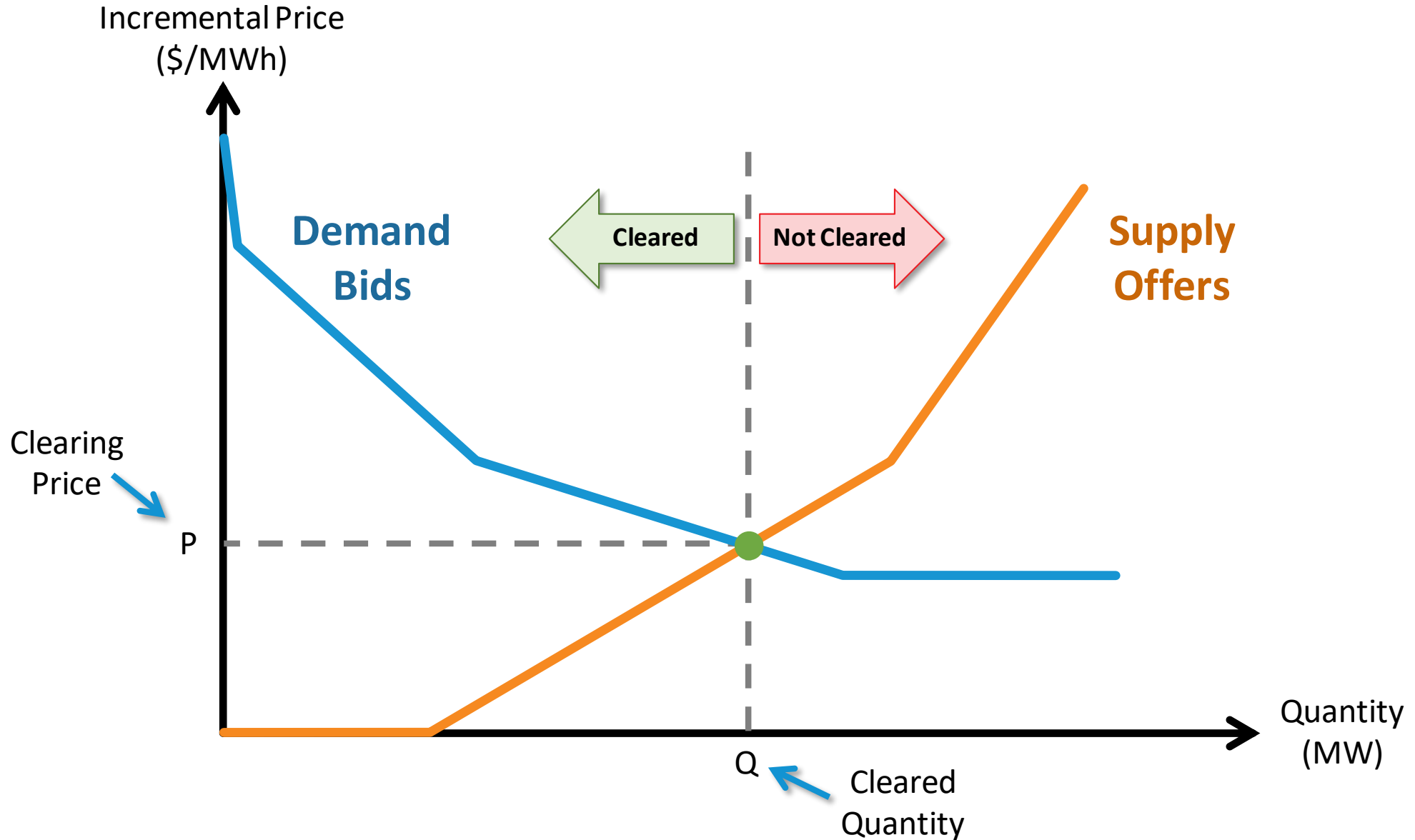

Offer Types

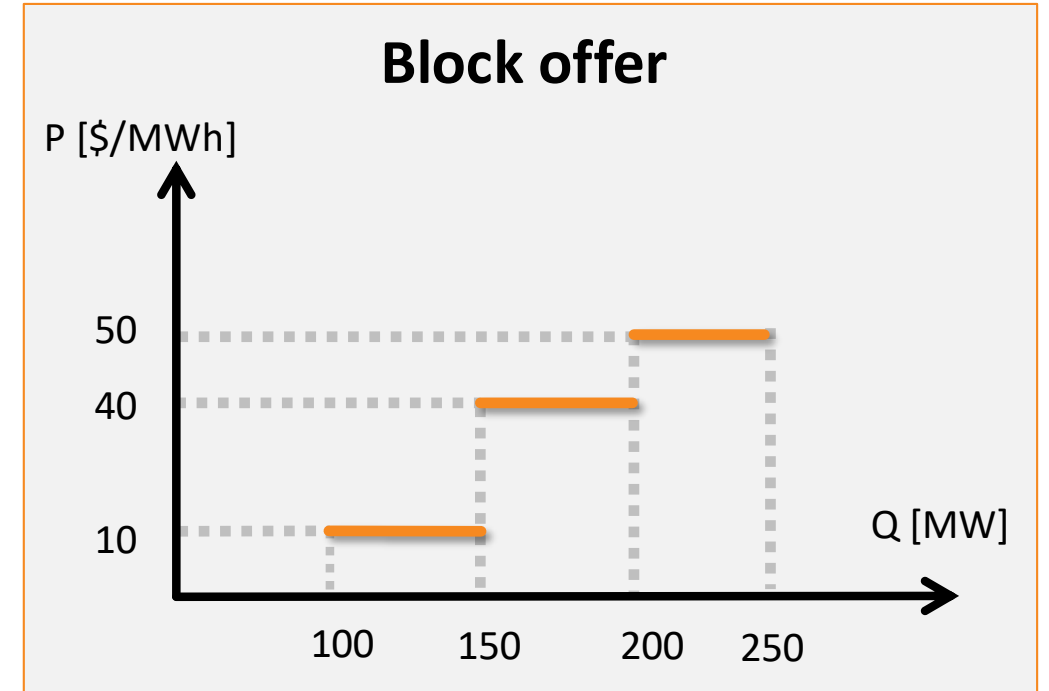
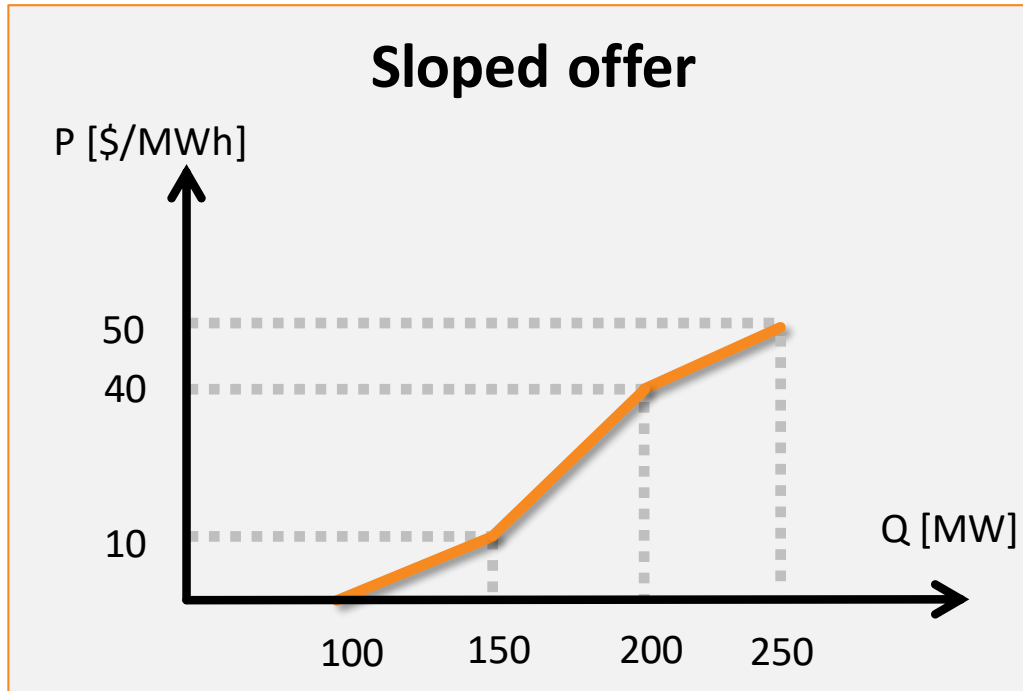

Each resource submits offers that specify incremental cost of producing energy

Clearing Market with Fixed Demand

i Real-time demand is typically fixed

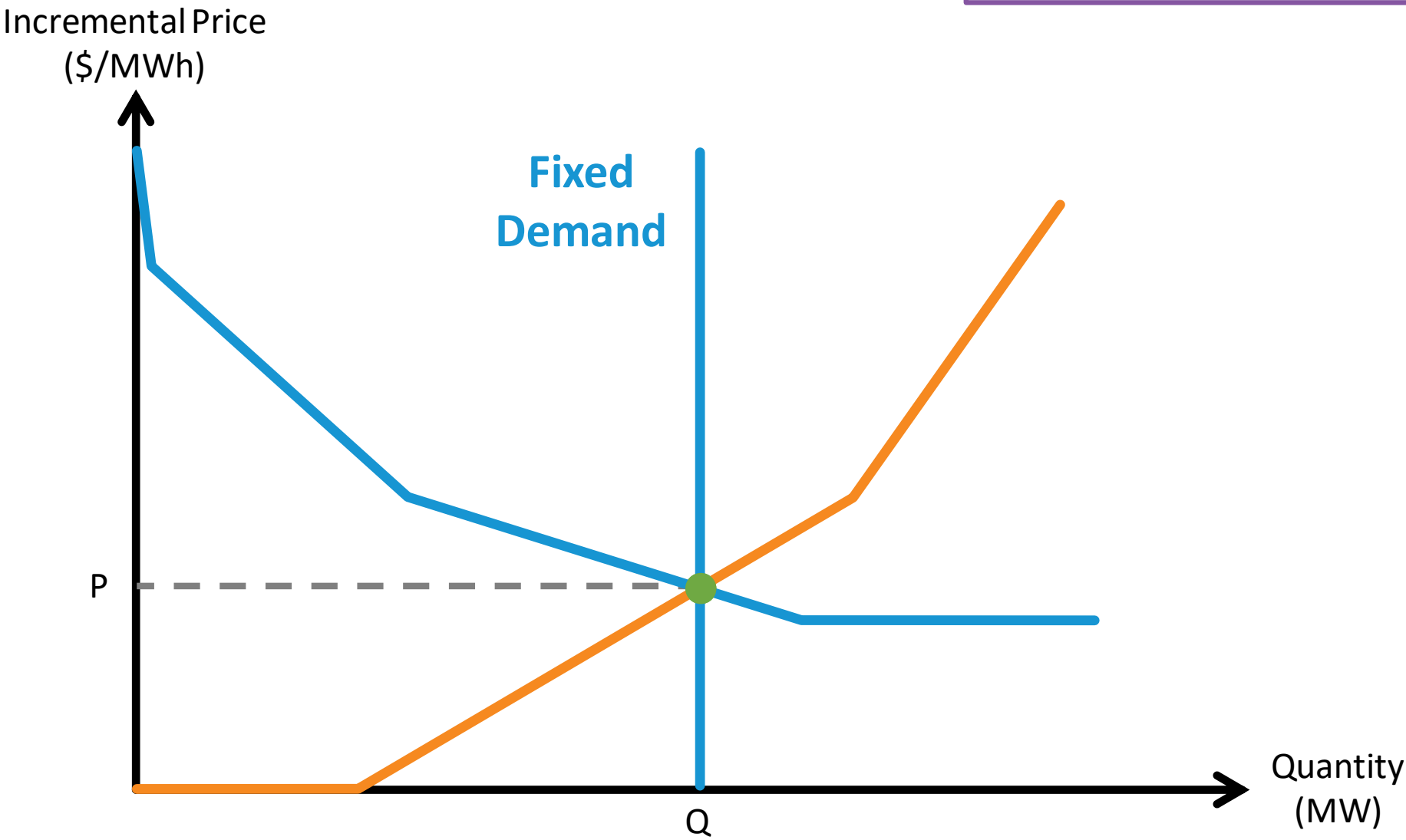

Economic Dispatch Optimization

Objective

- Maximize social welfare (minimize production cost)

Constraints

- Energy balance: **supply** = **demand**
- Transmission capacity: flow on each transmission constraint \leq line limit
- Resource capacity: $e_{\min} \leq \text{supply} \leq e_{\max}$



Marginal Resource and LMP

Locational *Marginal* Price

Definition: Cost of supplying an increment of load at a particular location

- Produced as a result of economic dispatch

Think of LMP as a change of the total production cost to deliver an *additional* increment of load to a location

Marginal Resource

- Provides the next increment of supply
- Between ecomin and ecomax
- Sets LMP



Marginal Price Calculation

Dispatchable Units Will End Up in One of Three Groups:

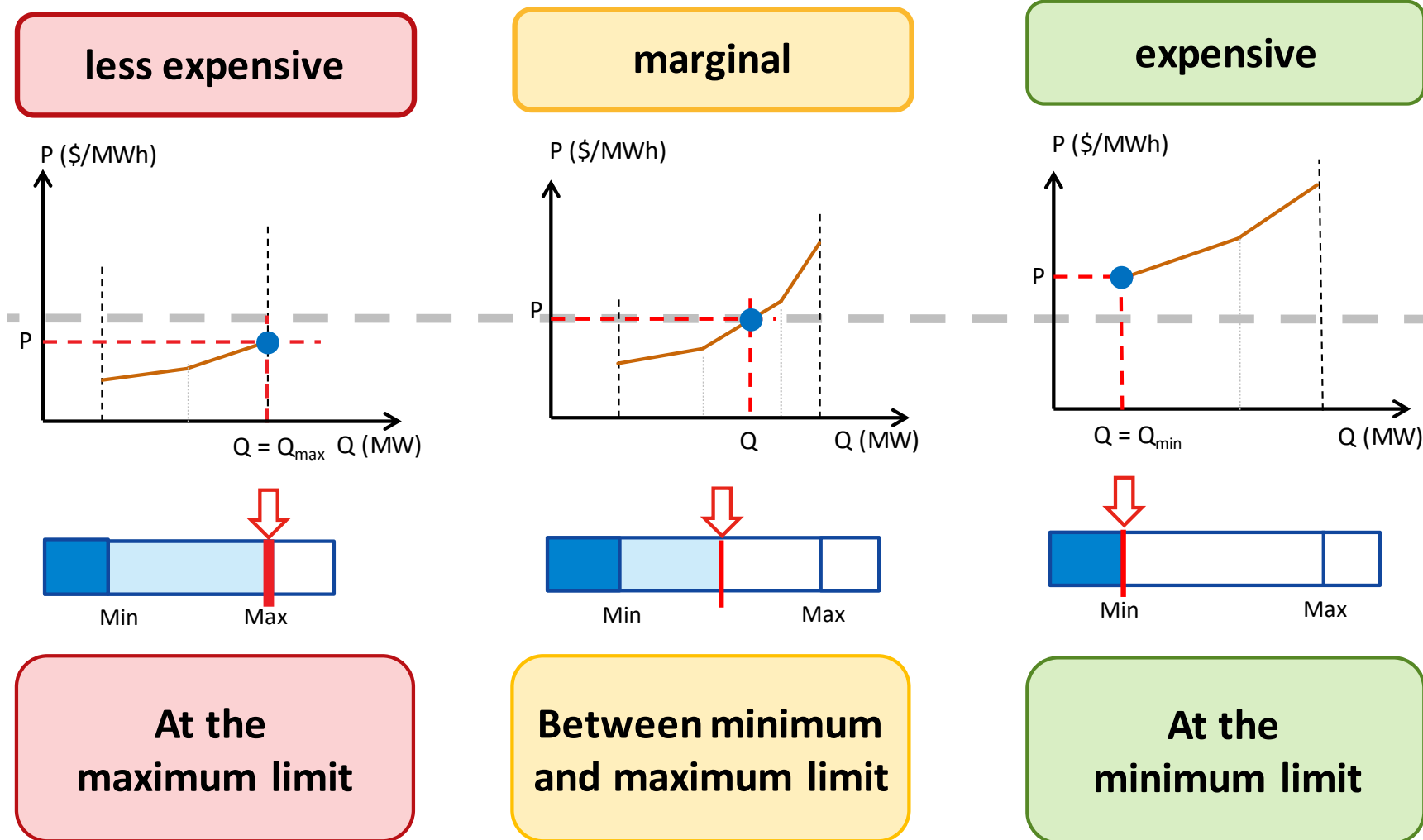



Questions?

Calculating LMPs with No Binding Constraints

Symbols Used

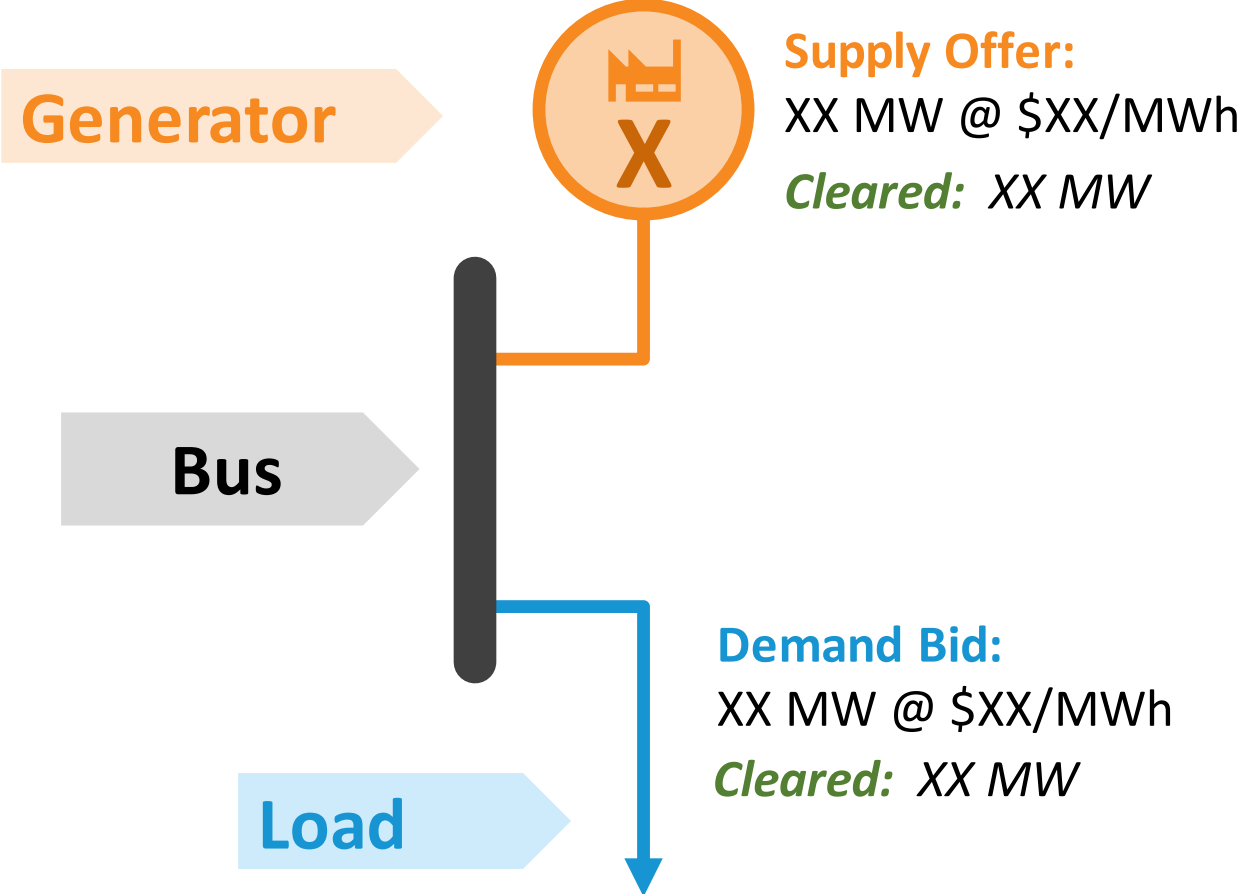

Transmission Constraints

- Transmission system elements are limited by how much power they can transfer
- When a limit is reached, the system becomes **congested** (constraint is **binding**) ; otherwise, it is not congested or binding

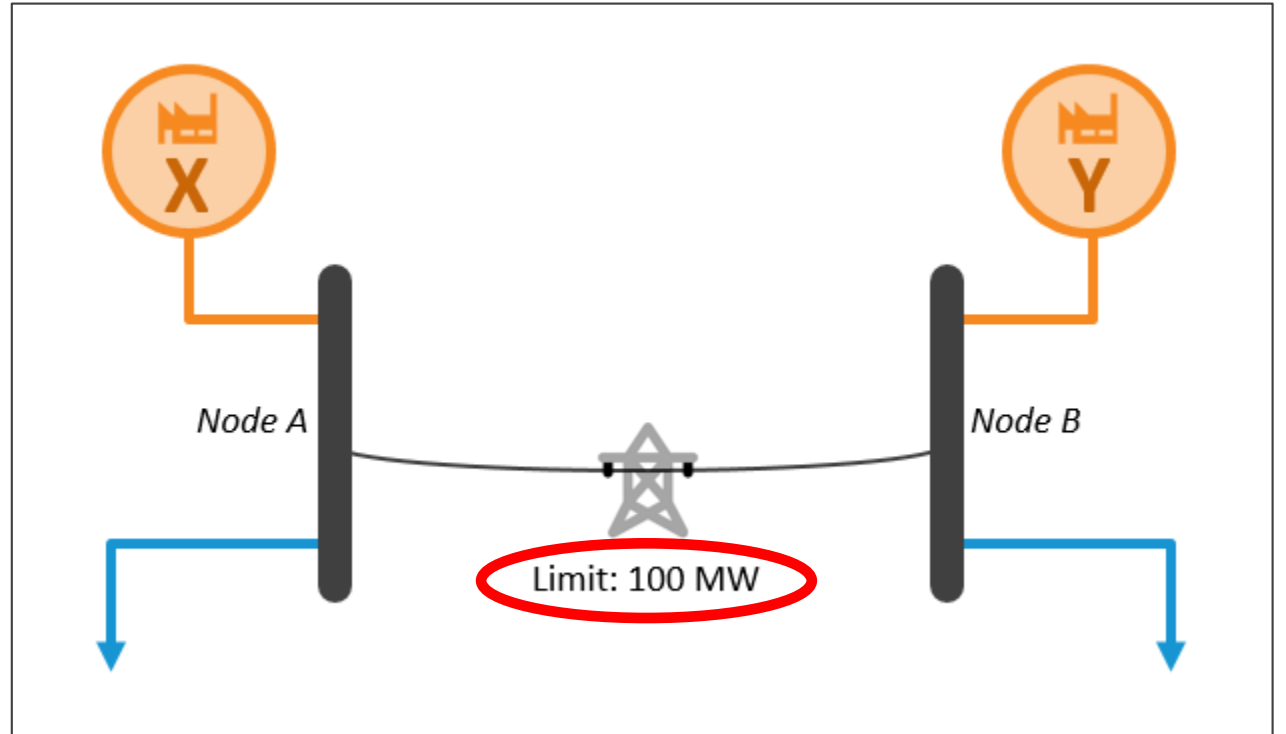

LMPs with No Binding Constraint – Supply Sets LMP

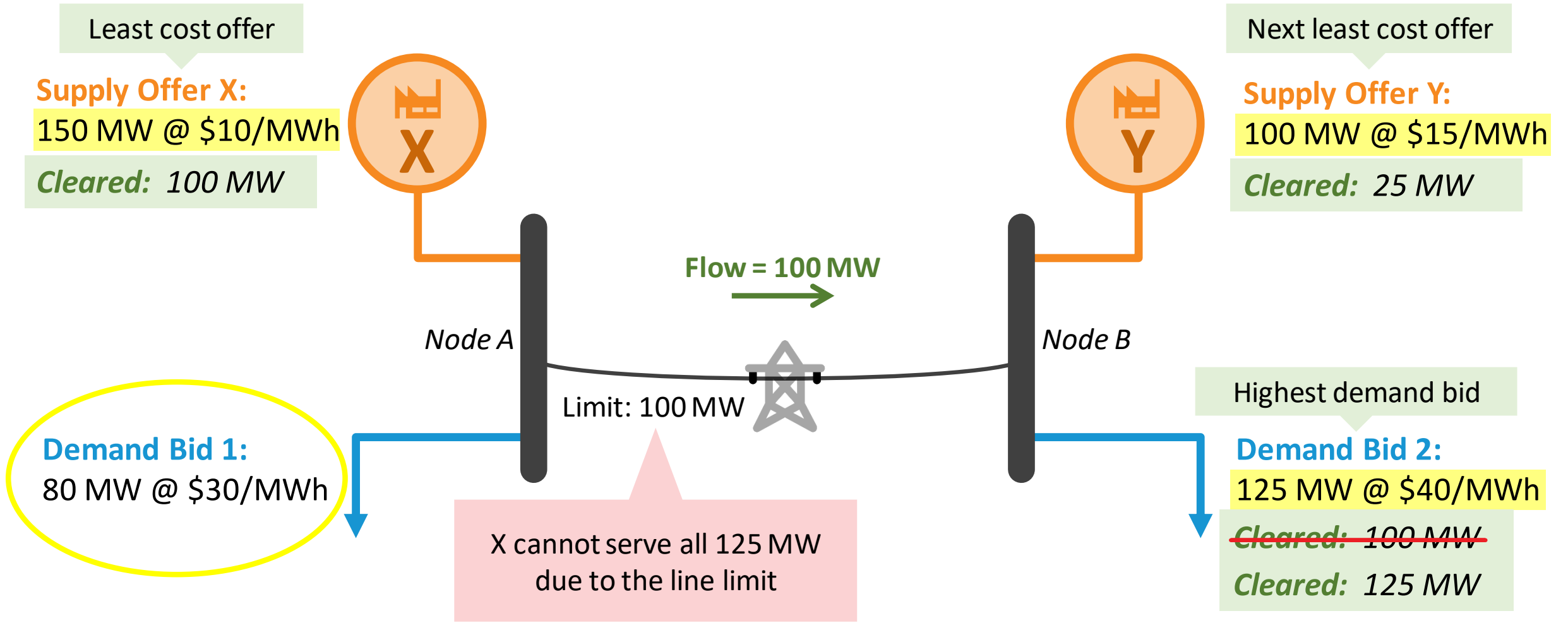

LMPs with No Binding Constraint – Supply Sets LMP, continued

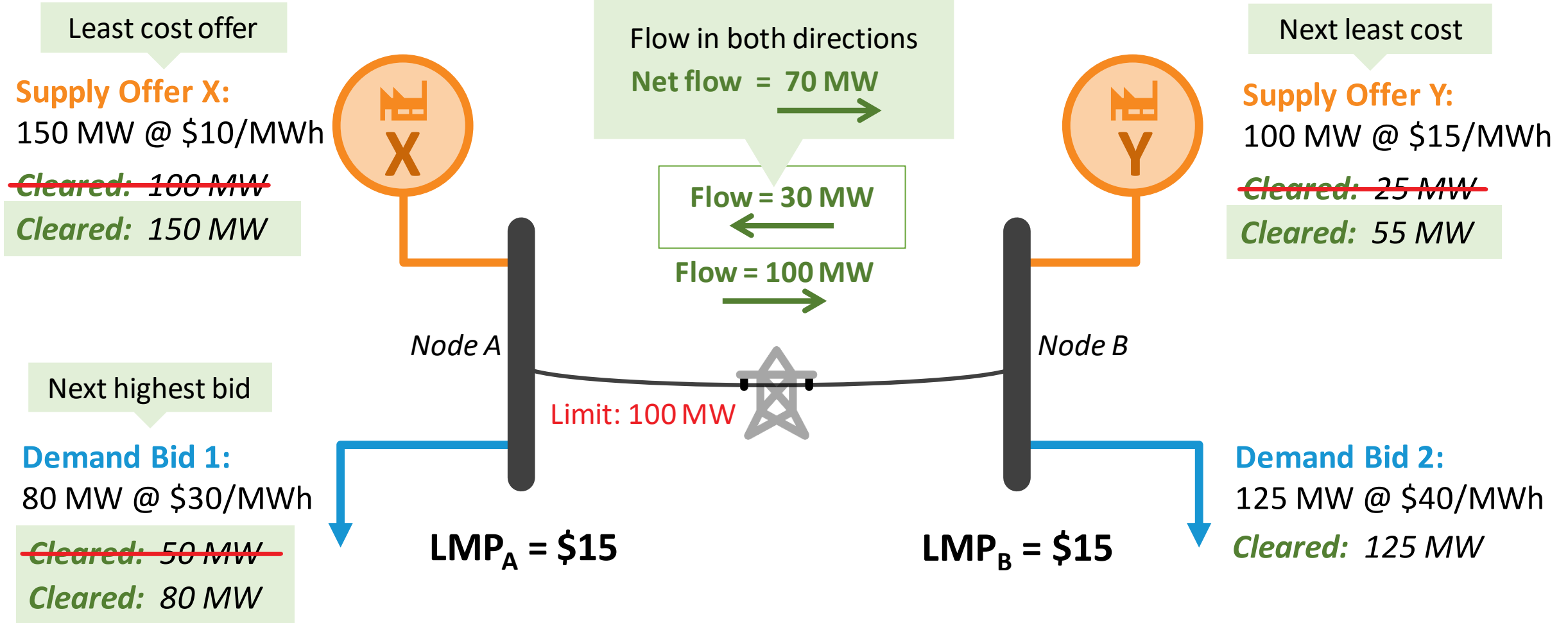

LMPs with No Binding Constraint – Supply Sets LMP, *continued*

Supply Offer X:

150 MW @ \$10/MWh

Cleared: 150 MW

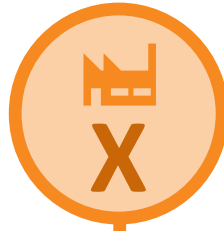

One
Marginal Resource

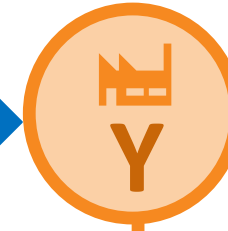

Supply Offer Y:

100 MW @ \$15/MWh

Cleared: 55 MW

Demand Bid 1:

80 MW @ \$30/MWh

Cleared: 80 MW



Node A

Flow = 70 MW



Node B

Limit: 100 MW

Demand Bid 2:

125 MW @ \$40/MWh

Cleared: 125 MW

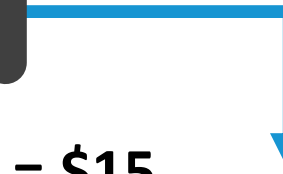

$LMP_A = \$15$

No Congestion
Same LMP

$LMP_B = \$15$

LMPs with No Binding Constraint – Load Sets LMP

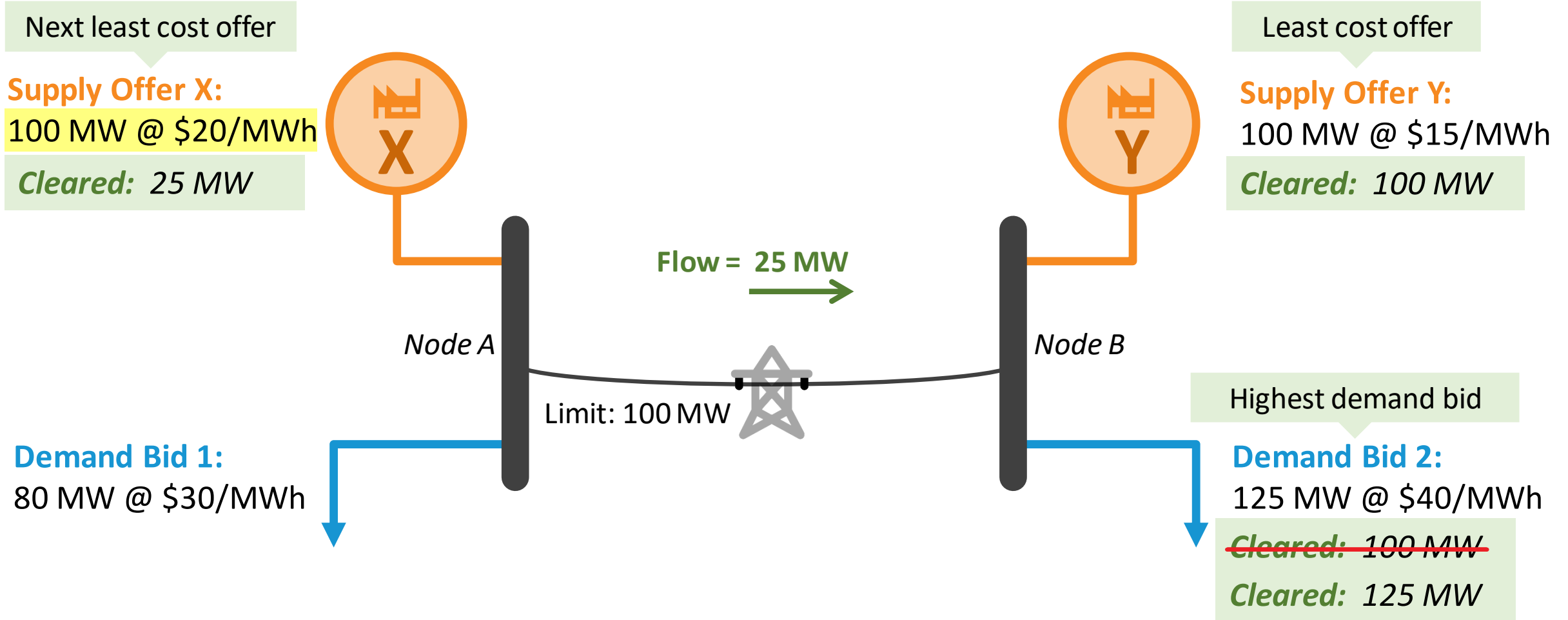

LMPs with No Binding Constraint – Load Sets LMP, *continued*

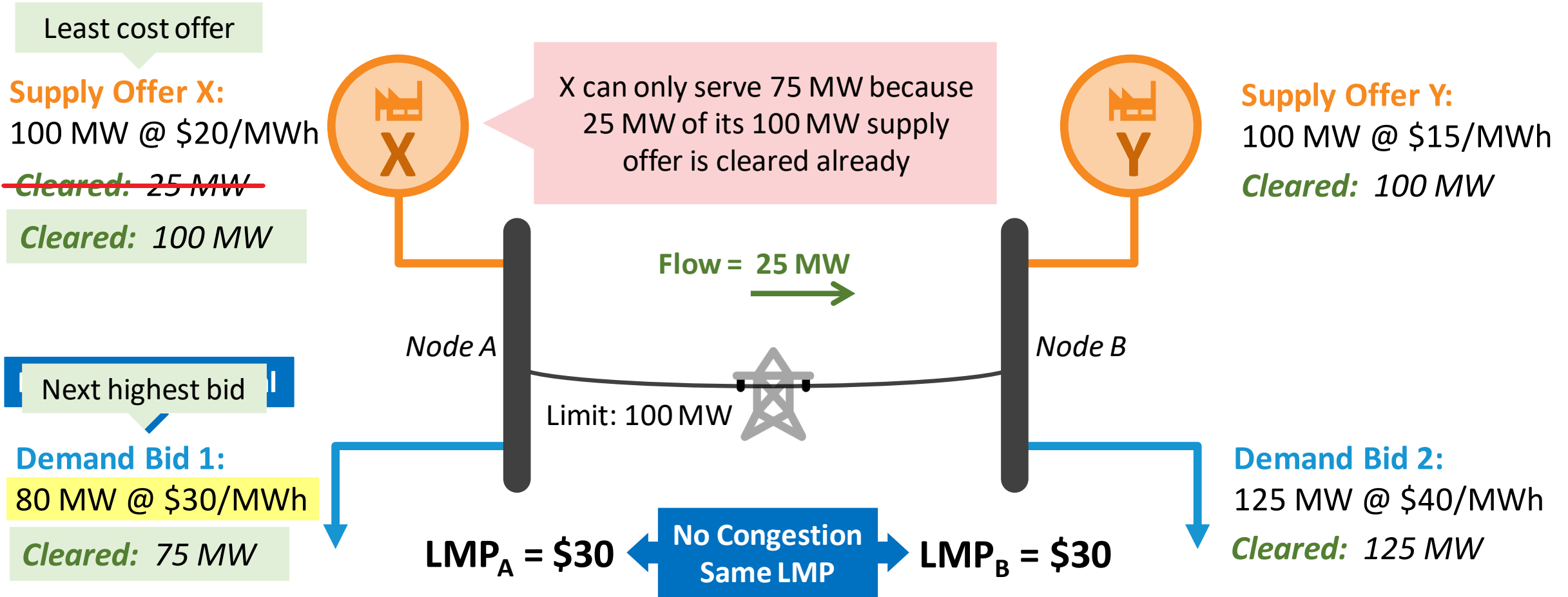

Calculating LMPs with Binding Constraints

How does a congested transmission line affect LMPs?



Binding Constraints Example

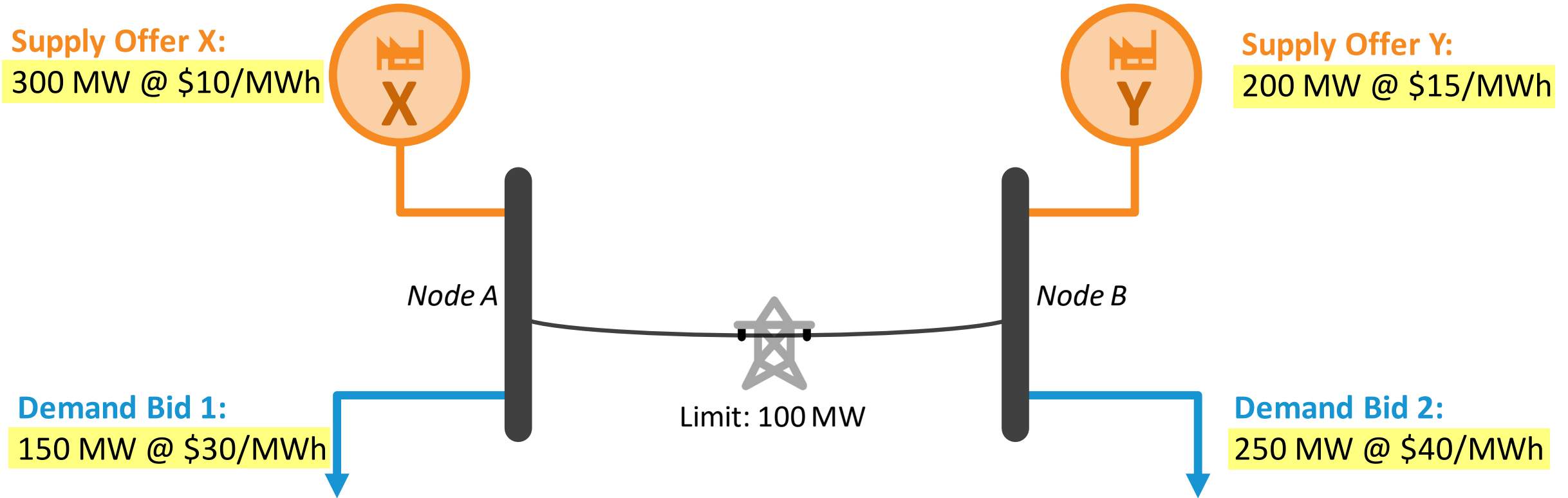

Binding Constraints Example, *continued*

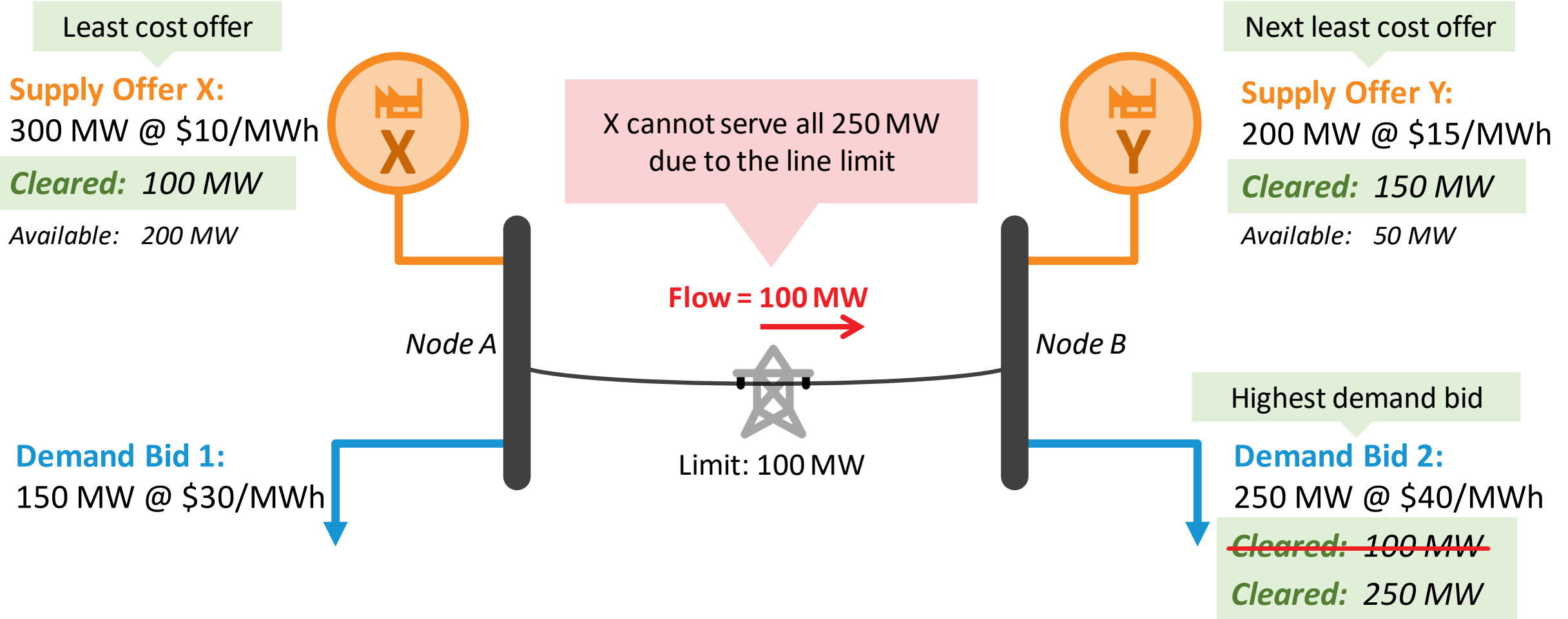

Binding Constraints Example, *continued*

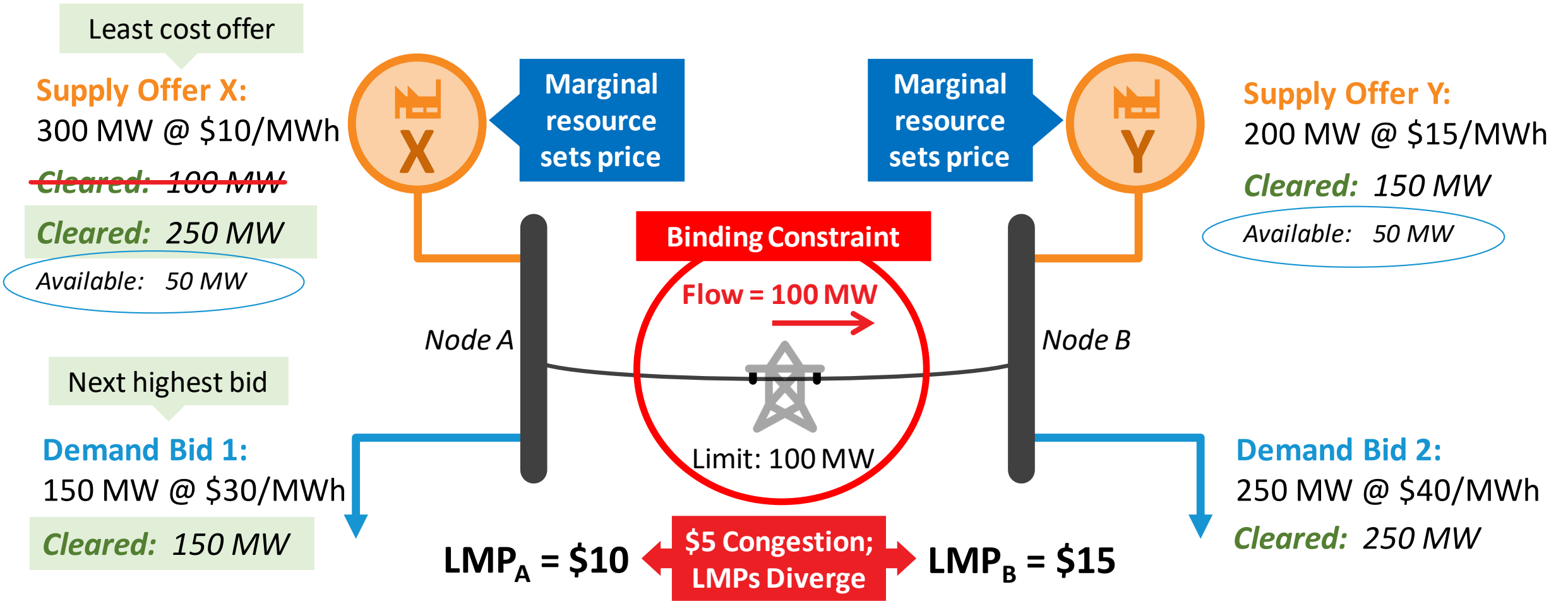

Effects of Congestion

Supply Offer X:

300 MW @ \$10/MWh

Cleared: 250 MW

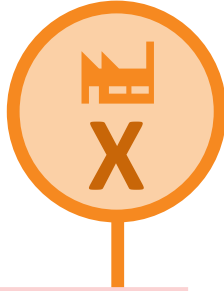

Higher-cost generation must be dispatched to serve load in constrained locations, increasing price at these locations

With congestion, it is not possible to use energy from low-cost generators to serve all loads

Supply Offer Y:

200 MW @ \$15/MWh

Cleared: 150 MW

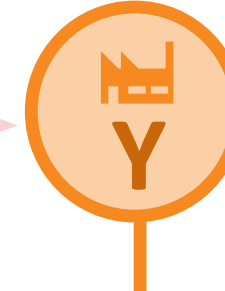

Demand Bid 1:

150 MW @ \$30/MWh

Cleared: 150 MW



Demand Bid 2:

250 MW @ \$40/MWh

Cleared: 250 MW

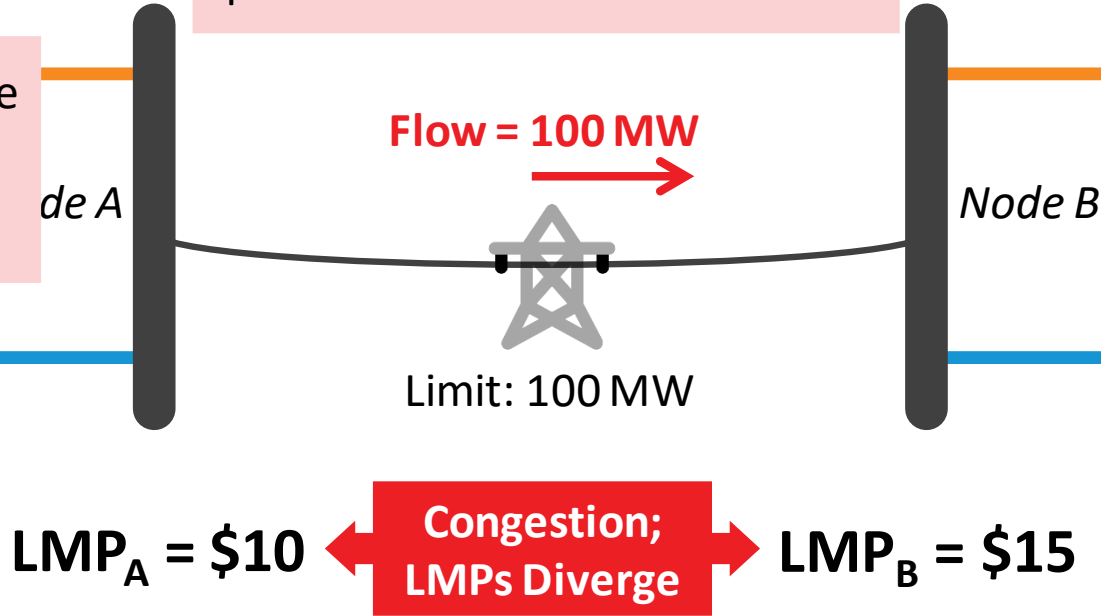
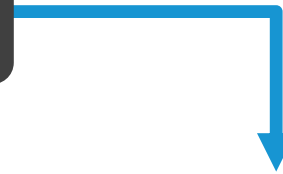

Exercise: Calculate LMP When There is a Binding Constraint

Answer the questions on the chart below

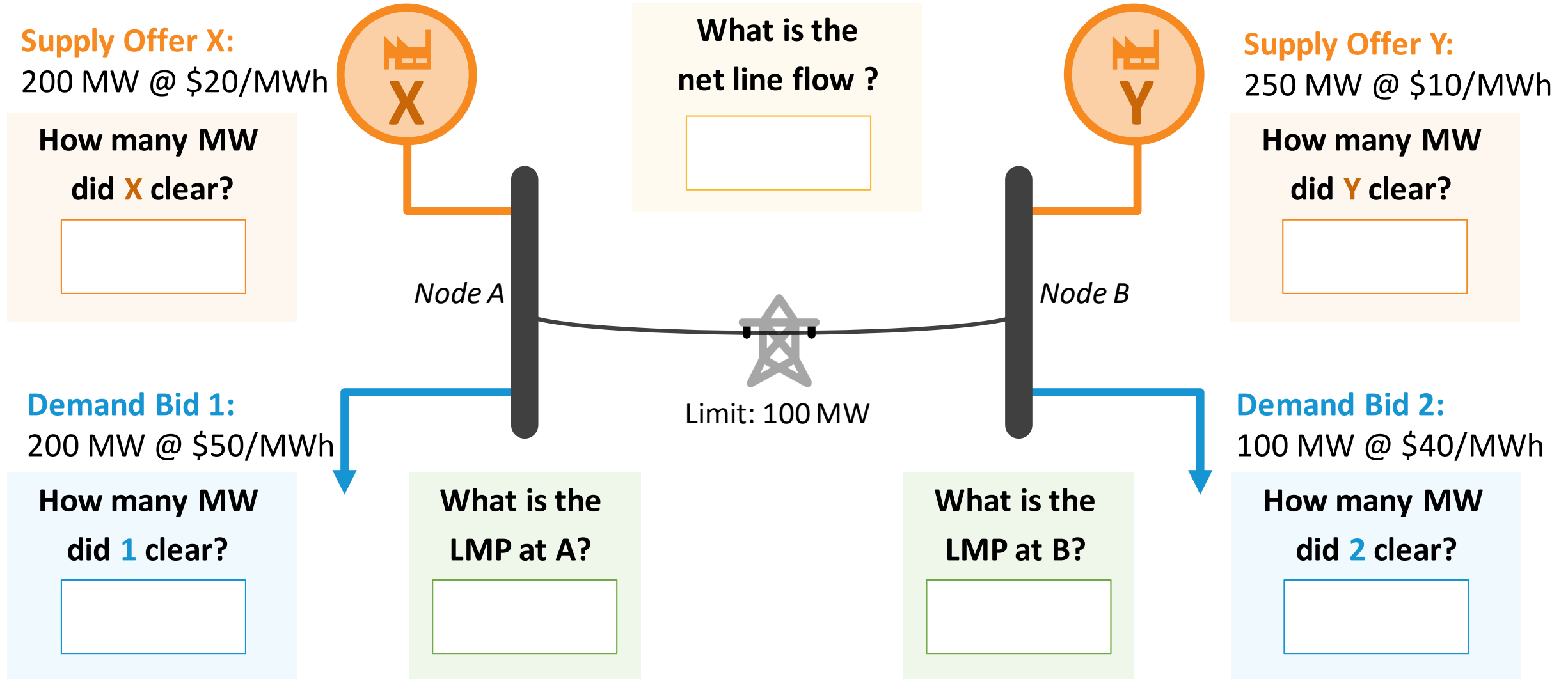

LMP Calculation – Fundamental Properties

- Price (LMP) at the location of each marginal unit is always equal to its offer price
- **n+1 Rule:** For n binding constraints, there are at least $n+1$ marginal units
- If no congestion, ≥ 1 marginal unit
- If there is no congestion and no losses, the LMP will be the same at each location





Questions?

How Transmission Line Impedance Impact LMPs

Power Transfer Distribution Factor



How Does Power Flow in a Network?

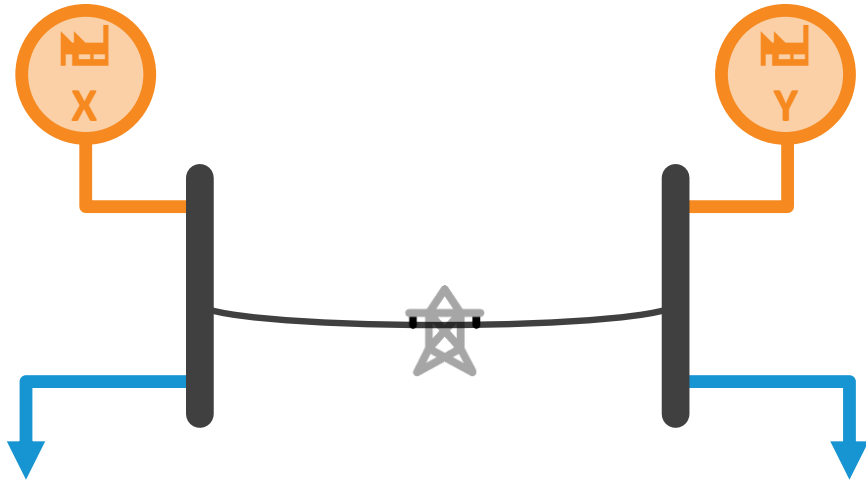

We saw how power flows across one line. How does power flow when more lines are available?

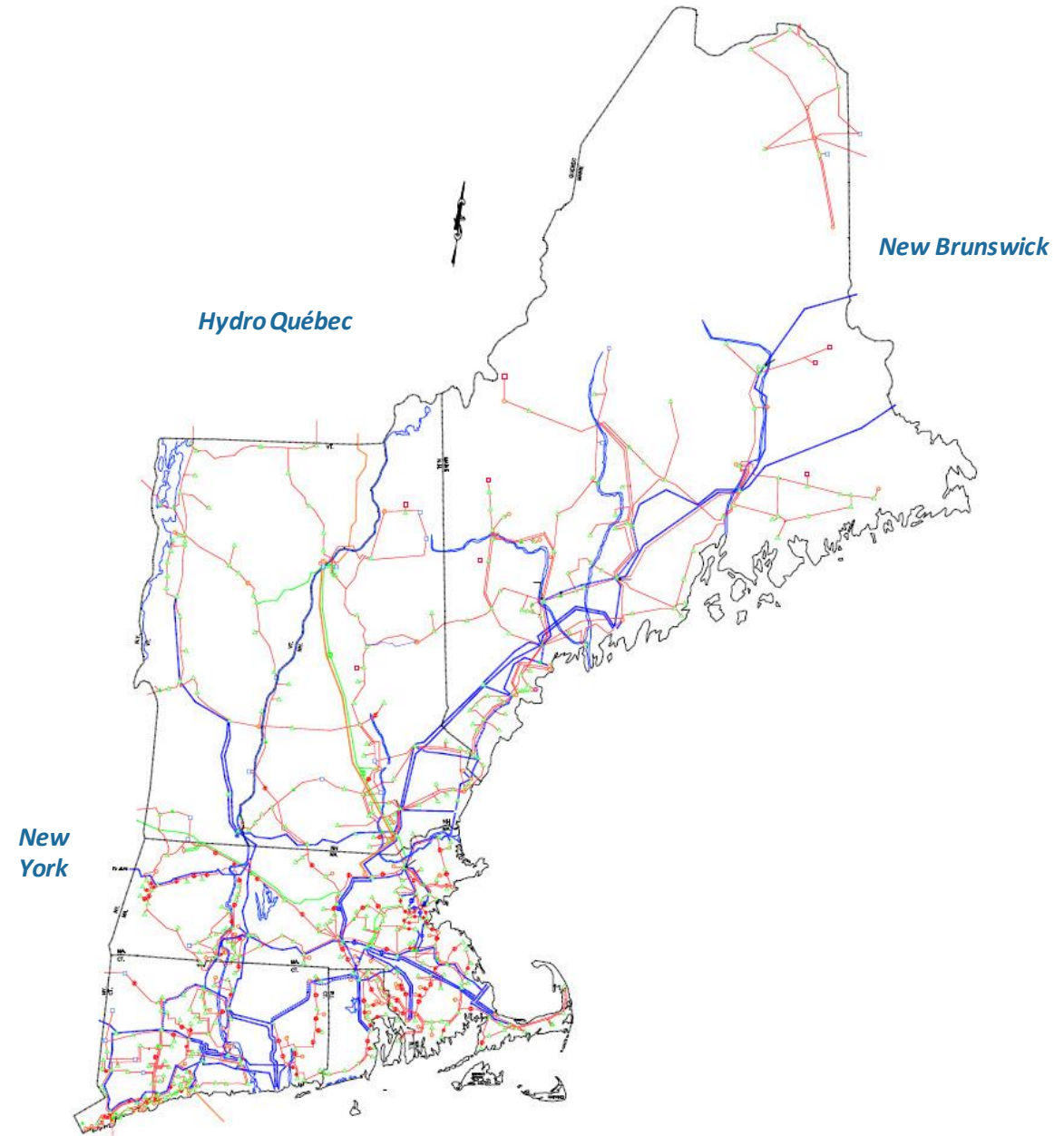

Impedance Measures the Opposition to Power Flow

The icon symbolizes "pushing against flow"

Lower Impedance

Higher Impedance

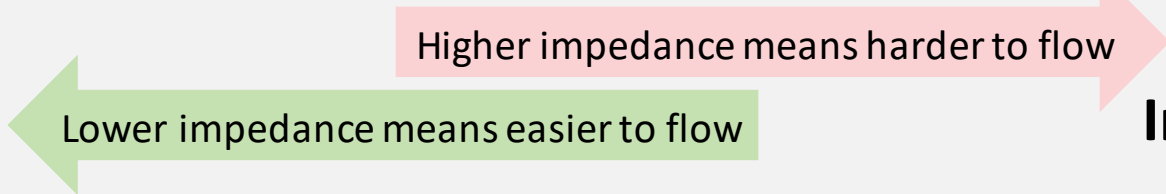

Length



Cross-section area



Copper

Type of material



Aluminum

Determine Line Flows in a 2-Node System

Lines With Equal Impedances

How much electricity flows across each line (Line 1 and Line 2)?

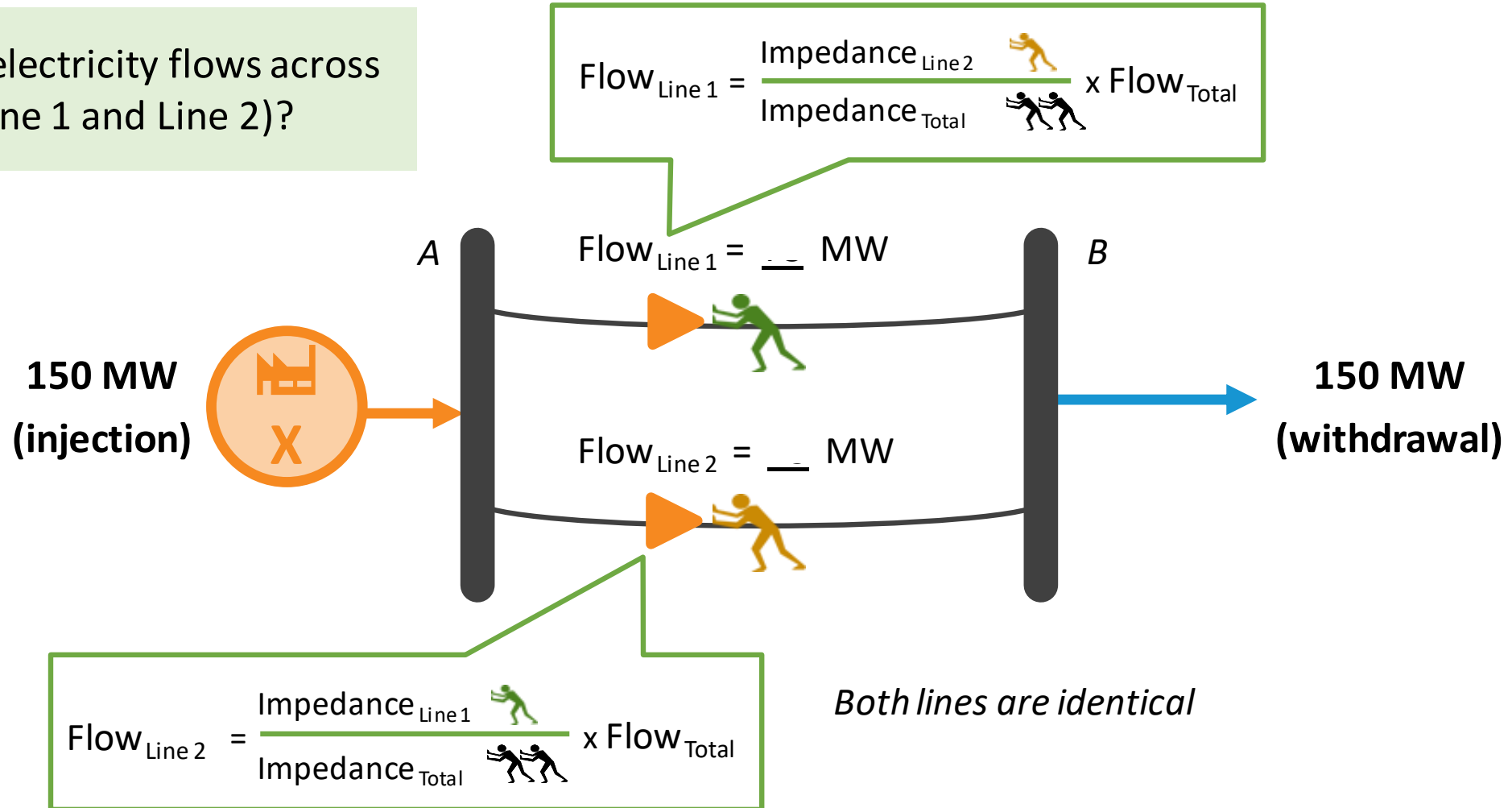

Determining the Line Direction, Flow Direction, and Flow Sign

Flow sign is relative to the chosen line direction

A positive (+) or negative (-) sign is used to indicate direction of flow based on the chosen line direction

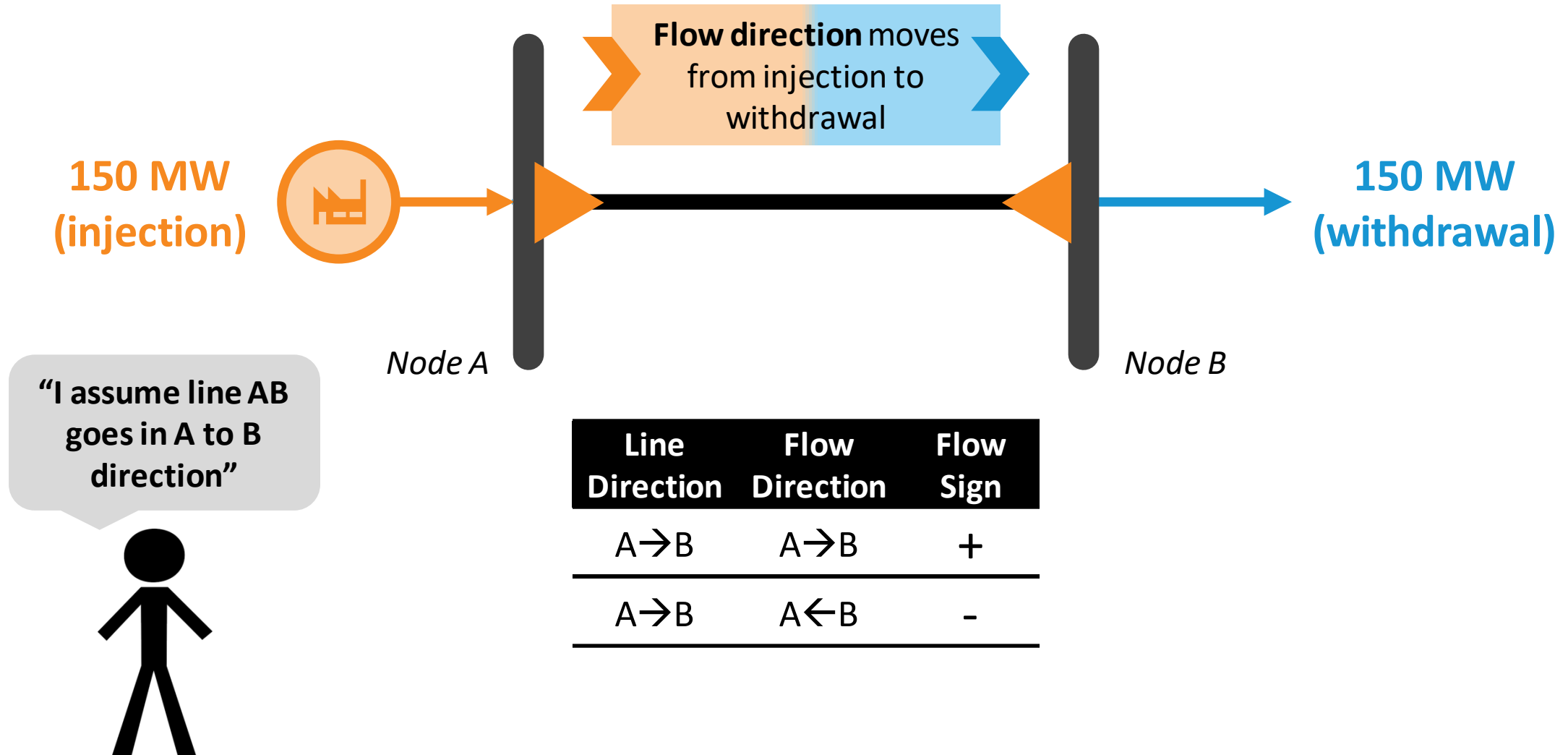

Determine Line Flow in a 2-Node System

Lines With Equal Impedances

- What is the sign of flow if the line direction is $A \rightarrow B$?
- What is the sign of flow if the line direction is $B \rightarrow A$?

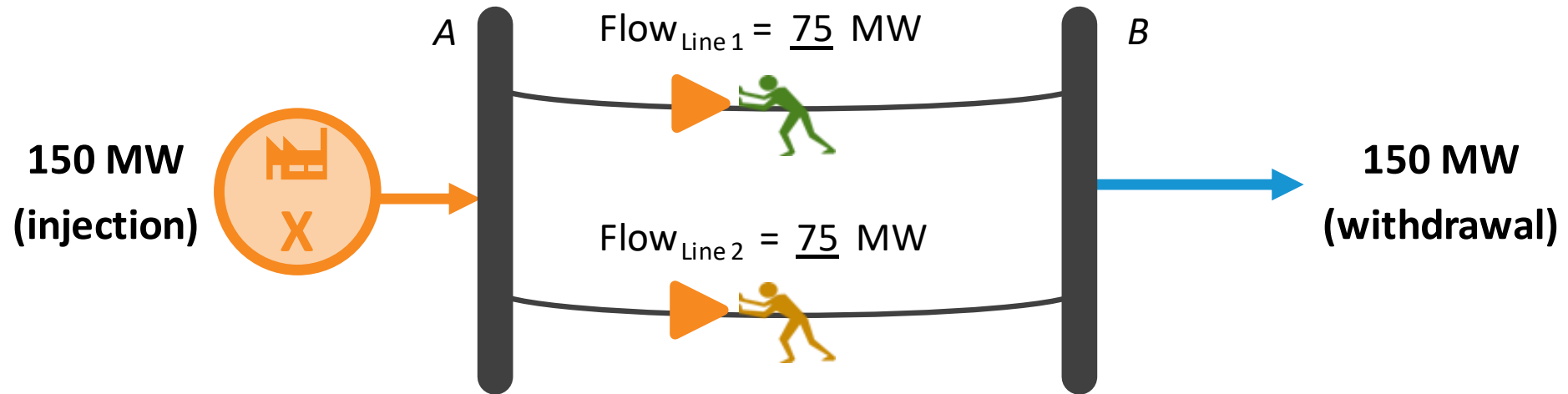

Both lines are identical

Flow on a transmission line can be expressed in terms of PTDF

Power transfer distribution factor (PTDF)

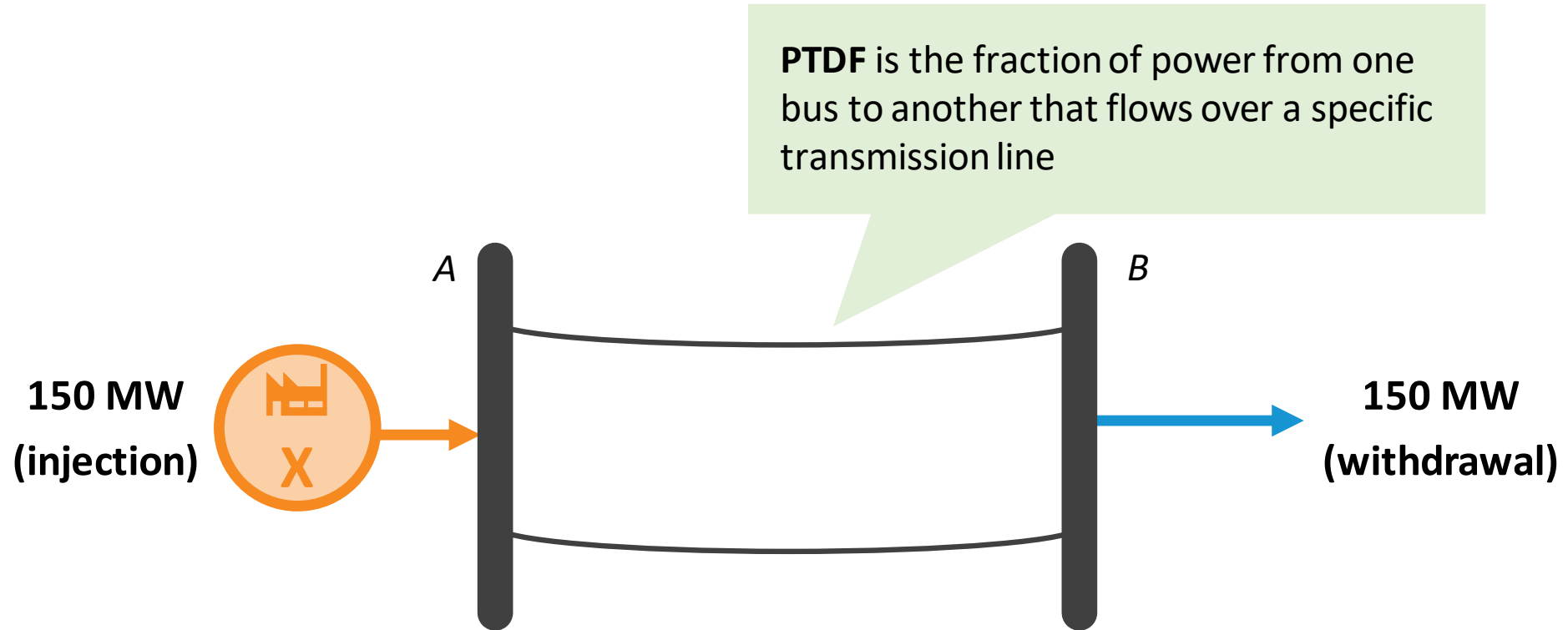

PTDFs are used to determine the change in line flows

Determine Line Flows and Direction in a 3-Node System

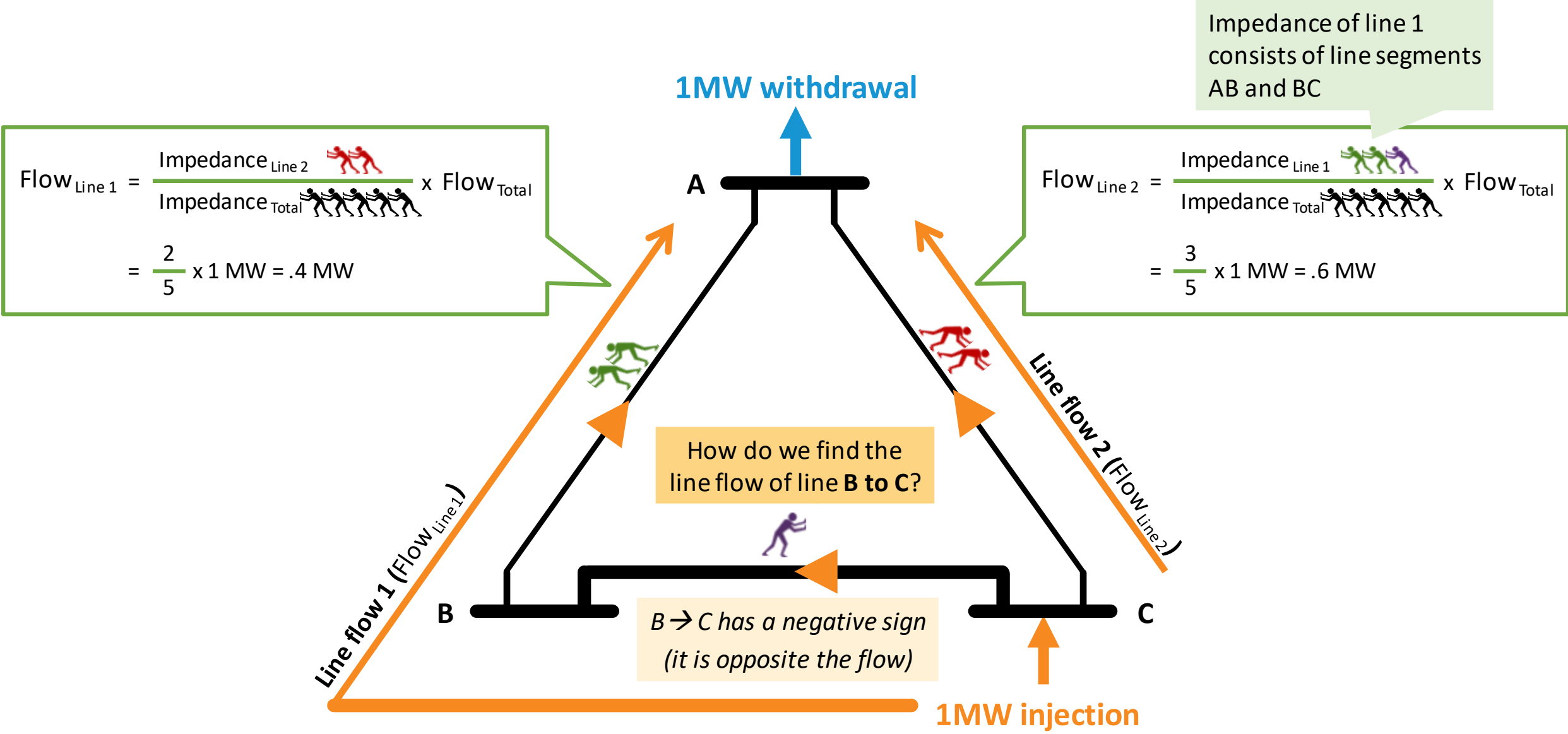

Example: What is PTDF for Line B to C?

"I assume line BC goes in B to C direction."

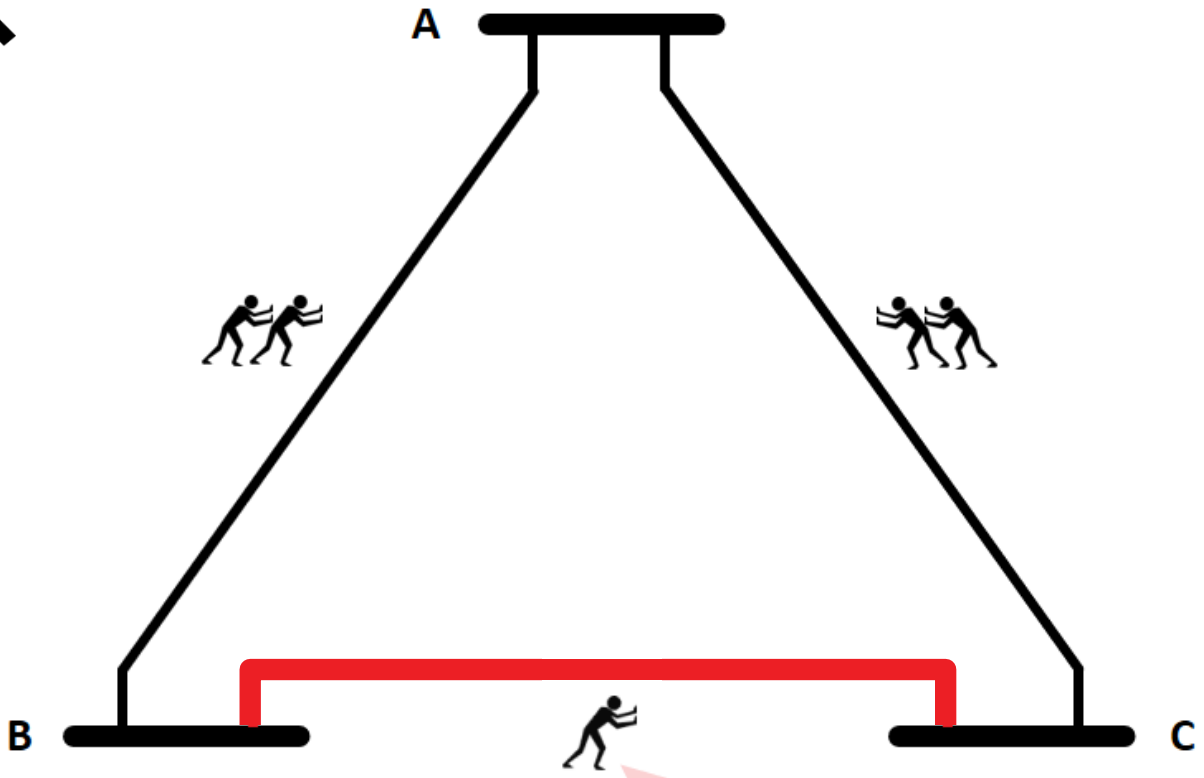

Find the PTDF for line B to C

PTDF for line B → C		Withdrawal Node		
		A	B	C
Injection Node	A	0	-0.4	0.4
	B	0.4	0	0.8
	C	-0.4	-0.8	0

Team Exercise: What is PTDF for Line $A \rightarrow C$?

Fill-in the PTDF for each line $A \rightarrow C$ for power transfer between any two nodes

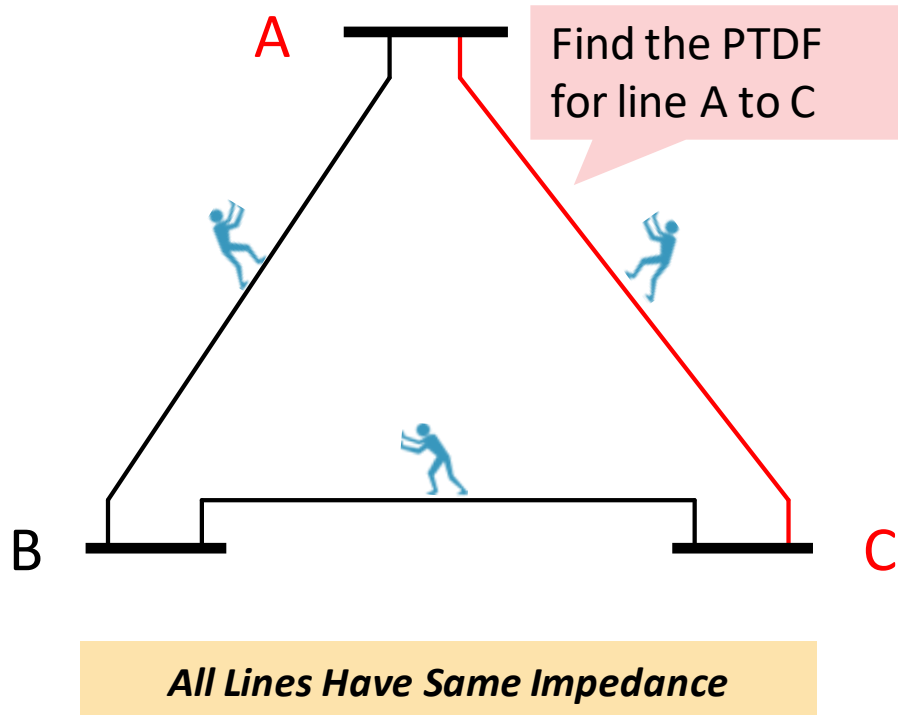

PTDF for line $A \rightarrow C$		1 MW to node ...		
		A	B	C
1MW from node ...	A	0		
	B		0	
	C			0

Using PTDF to Calculate LMPs in a 3-Node Power System

All Lines Have Same Impedance

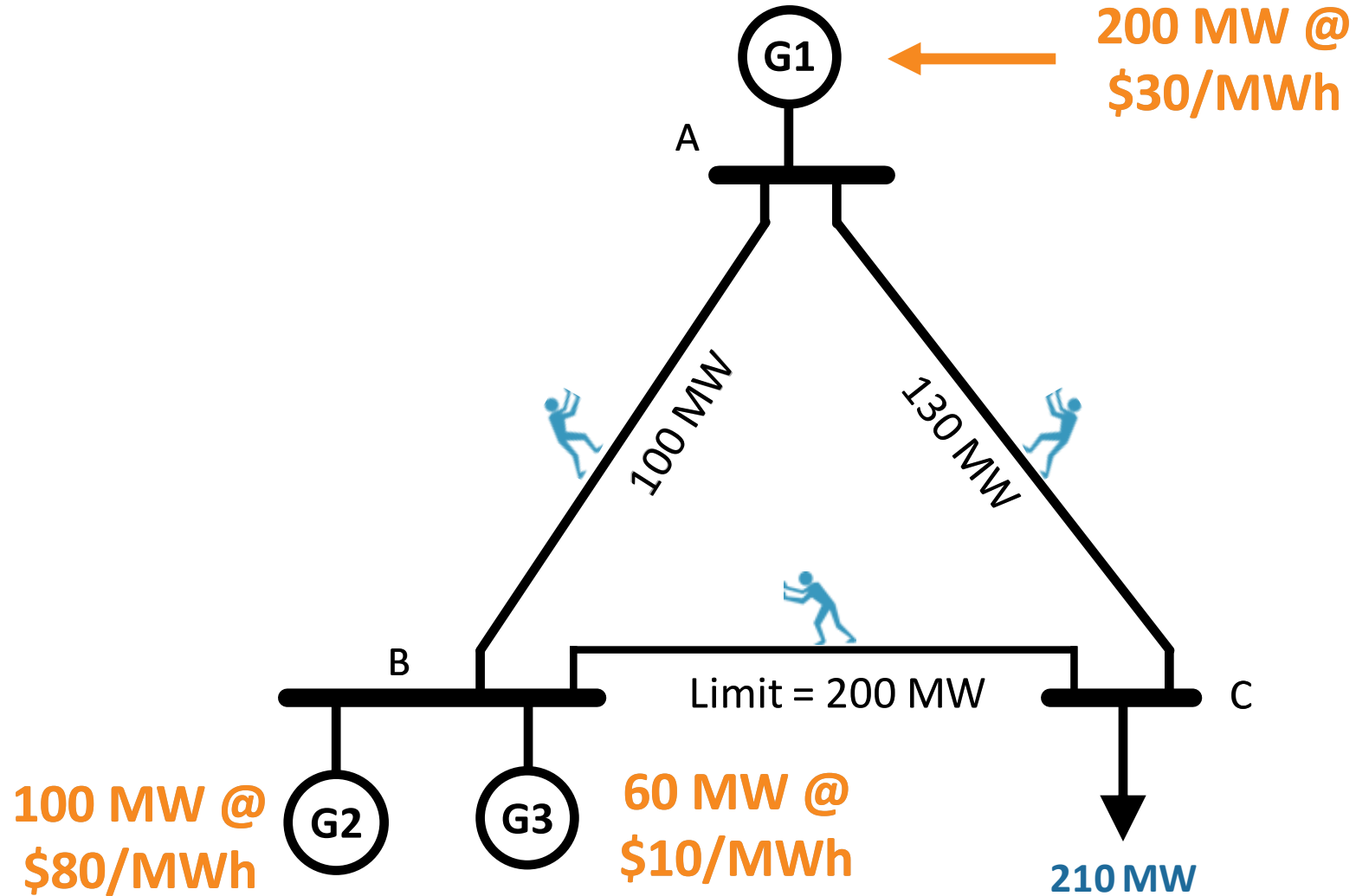

3-Node System: No Binding Constraint

All Lines Have Same Impedance

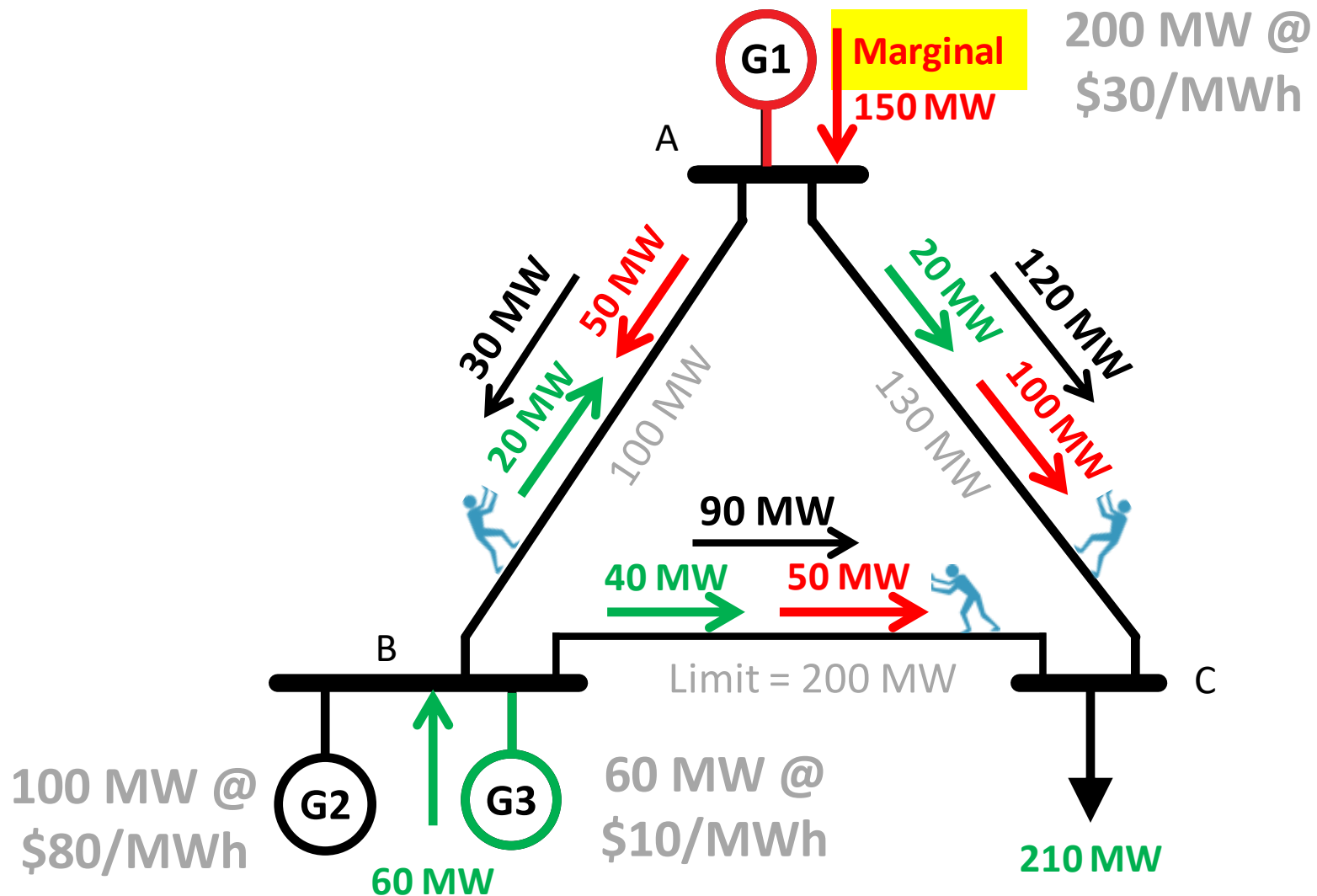

3-Node System: No Binding Constraint

All Lines Have Same Impedance

Merit Order

G3	60 MW	\$10 / MWh
G1	200 MW	\$30 / MWh
G2	100 MW	\$80 / MWh

LMPs are same at all locations!

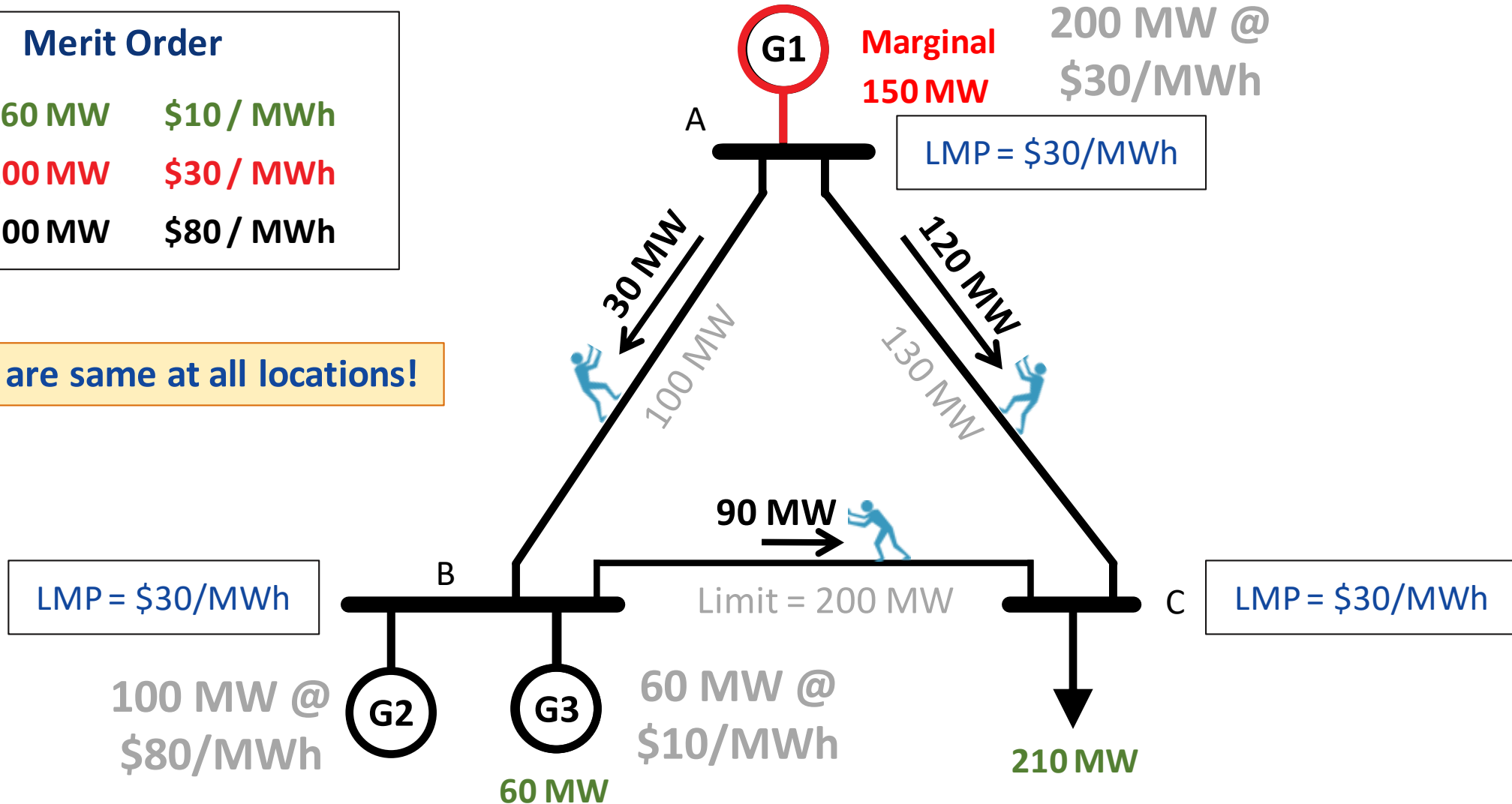

3-Node Power System: With Binding Constraint

All Lines Have Same Impedance

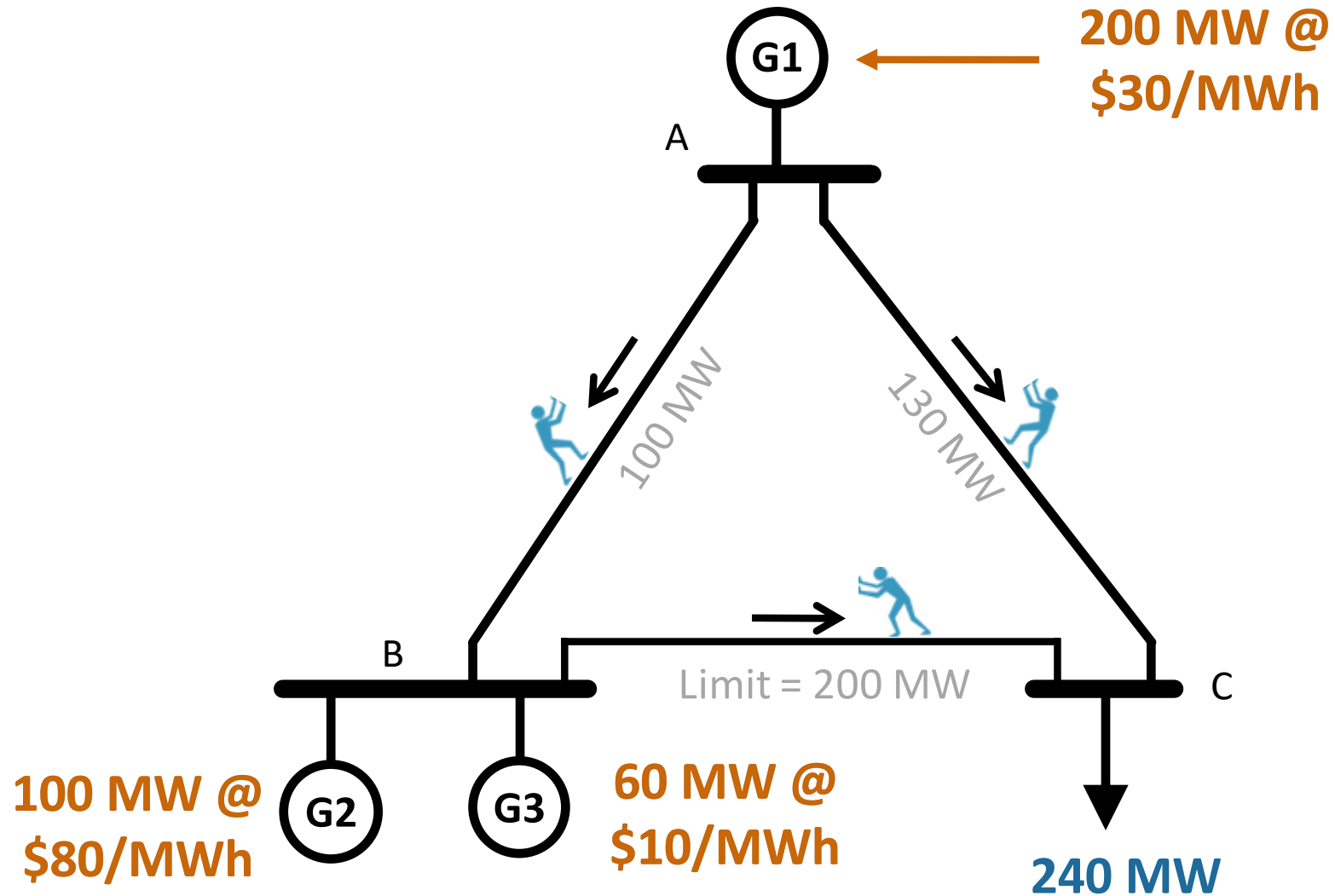

3-Node Power System: With Binding Constraint

All Lines Have Same Impedance

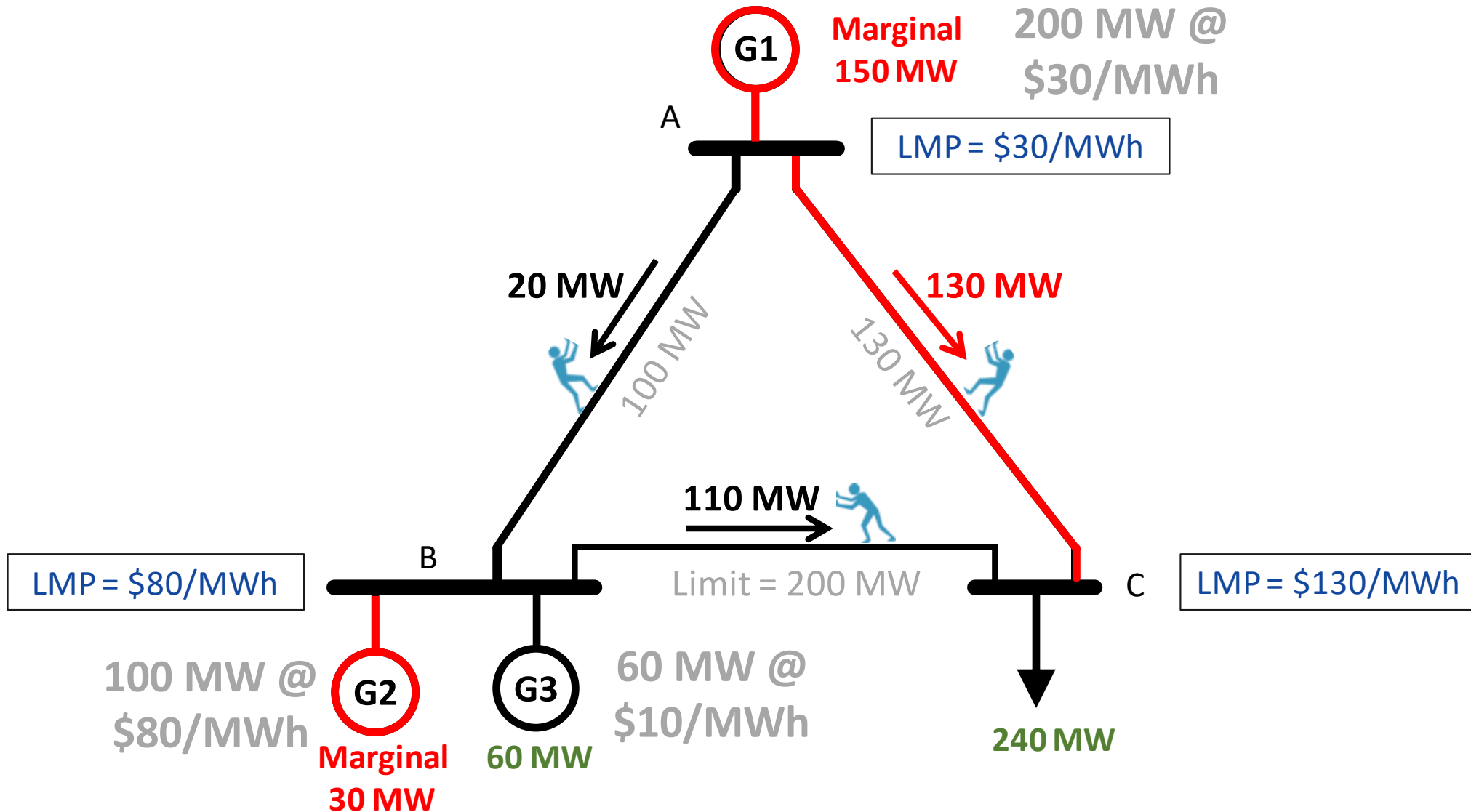

What if we need to serve an additional 1MW of load at Node C?

All Lines Have Same Impedance

200MW @ \$30/MWh

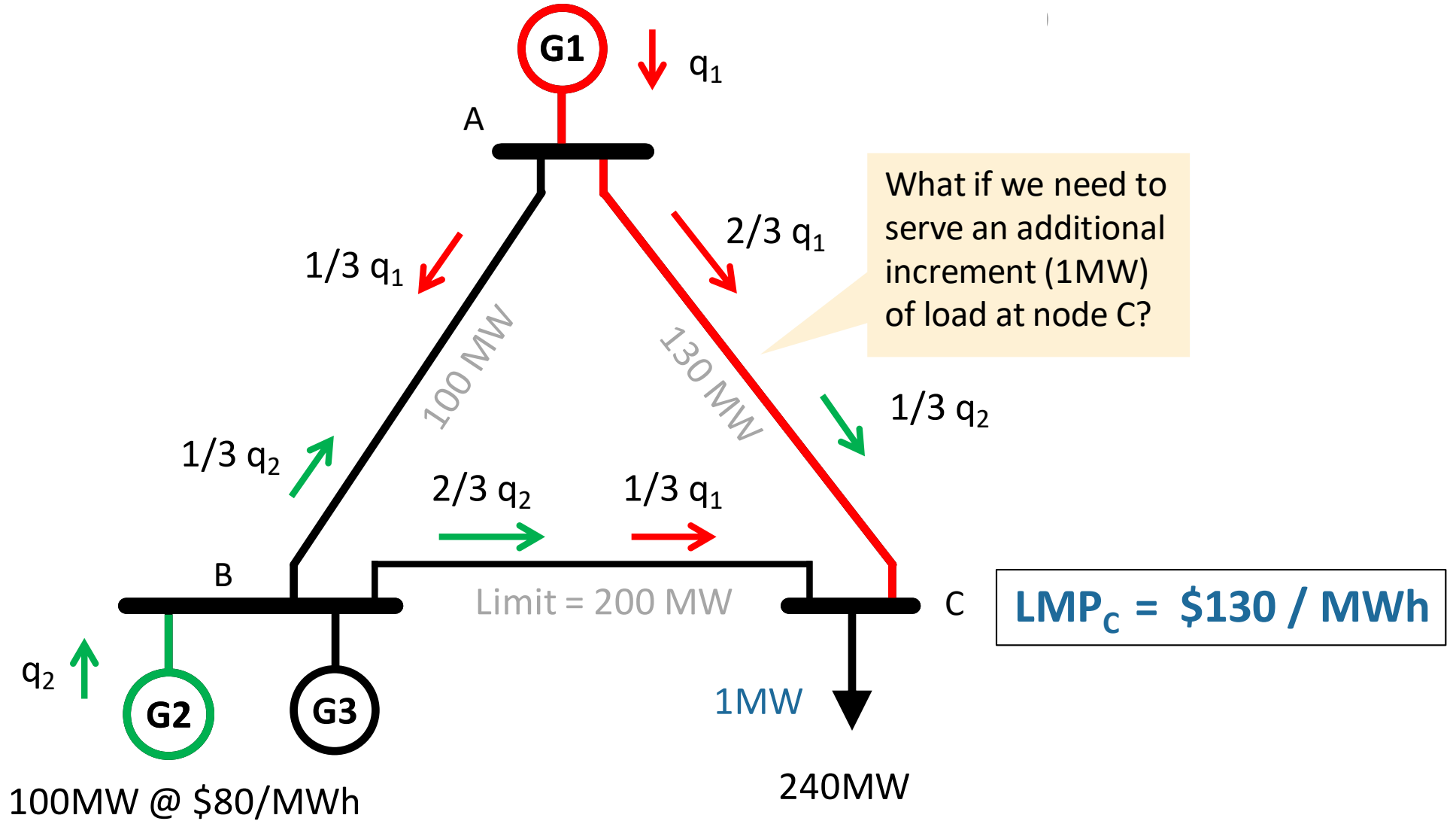

PTDF to Calculate LMP at C

Considerations:

- Need to serve an additional increment (1MW) of load at node C
- **Additional 1 MW** at C is served by change of generation in marginal resources Gen 1 (q_1) and Gen 2 (q_2)

$$q_1 + q_2 = 1$$

- **Flow on line A-C** cannot increase (already at the limit)

$$q_1 \cdot PTDF_{LineAC}^{A-C} + q_2 \cdot PTDF_{LineAC}^{B-C} = 0$$

$$\Rightarrow \frac{2}{3} q_1 + \frac{1}{3} q_2 = 0$$

- **LMP at node C** is equal to the increase of production cost due to supplying additional 1MW at that node

$$LMP_C = 30 \cdot q_1 + 80 \cdot q_2$$

PTDF to Calculate LMP at C

$$q_1 + q_2 = 1$$

$$\frac{2}{3}q_1 + \frac{1}{3}q_2 = 0 \quad / \times 3$$

$$q_1 + q_2 = 1$$

$$2q_1 + q_2 = 0$$

$$q_1 = -1, \quad q_2 = 2$$

$$LMP_C = 30 \cdot q_1 + 80 \cdot q_2$$

$$LMP_C = 30 \times (-1) + 80 \times 2$$

$$LMP_C = 130$$

Exercise: PTDF to Calculate Price with Congestion

Using cheat sheet on next slide, calculate the LMP at Node C



All Lines Have Same Impedance

200 MW @ \$20/MWh
Cleared = 160 MW
 $LMP_A = \$20/\text{MWh}$

60 MW @ \$10/MWh
Cleared = 40 MW
 $LMP_B = \$10/\text{MWh}$

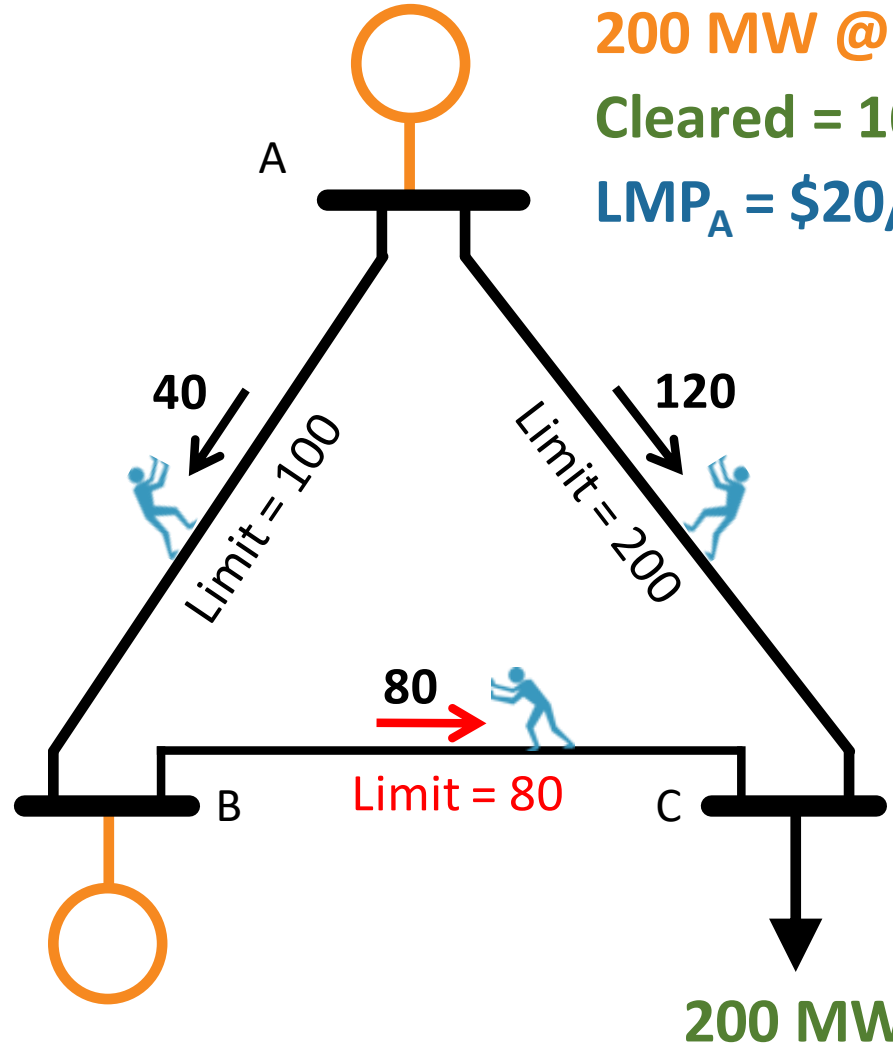

$LMP_C = \underline{\hspace{2cm}} \text{ [$/MWh]}$

Answers will be provided in a separate handout

Exercise Cheat Sheet: PTFD to Calculate Price with Congestion



Use this information to complete the exercise on the previous slide

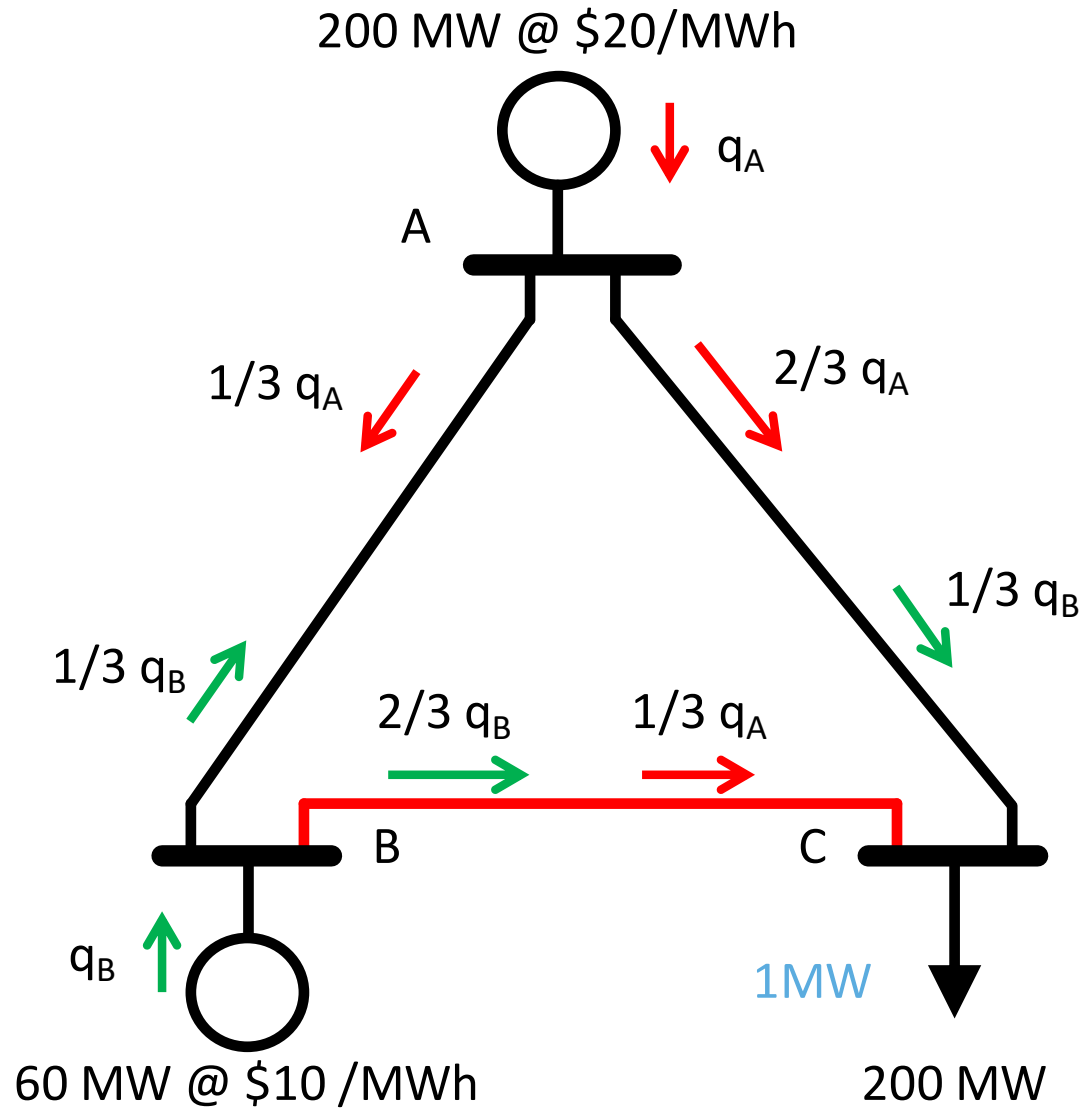

How Transmission Line Impedance Impact LMPs

Generator Shift Factors



Generator Shift Factors (GSF)

- A specific type of PTDF
- Used to measure the impact to an element of the system of deliveries from every location to a single reference point
- Calculated for each limiting element in the system or each binding constraint in the system
- Used by the ISO unit dispatch software

GSF, continued

- Determine GSF for line **C** → **A**, in regard to all locations
- Calculate all PTDF for line **C** → **A**
- All three lines are identical
- Reference bus = **B**

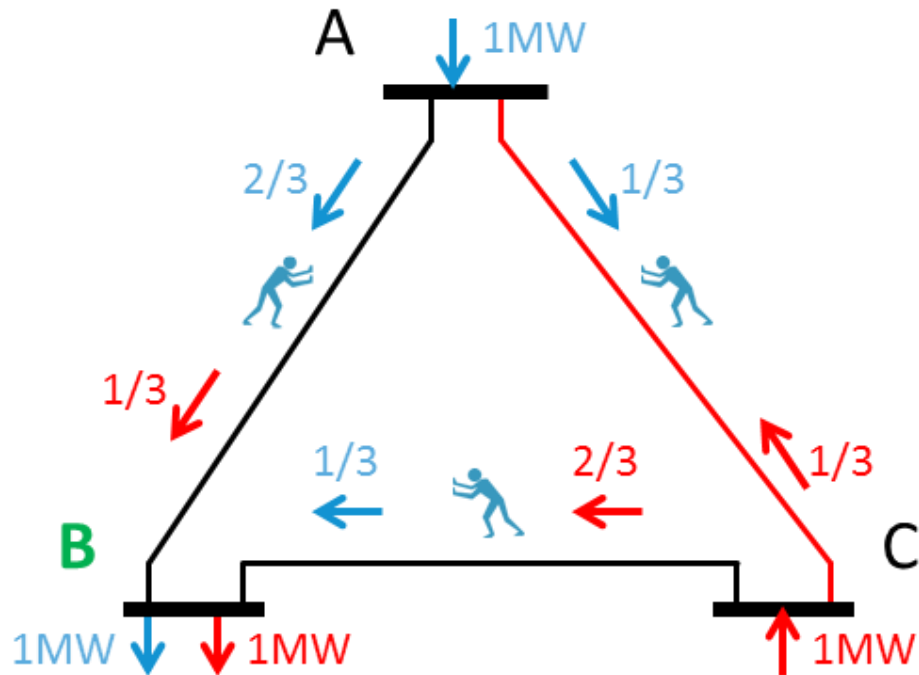

Line C → A				
GSF		PTDFs		
		To		
		A	B	C
A	-1/3			
B	0			
C	1/3			
From	A	0	-1/3	-2/3
	B	1/3	0	-1/3
	C	2/3	1/3	0

$$PTDF_{lineCA}^{A \rightarrow C} = GSF_{lineCA}^A - GSF_{lineCA}^C$$

LMP Components

$$\text{LMP} = \text{Energy} + \text{Losses} + \text{Congestion}$$

$$LMP_i = LMP_E - \cancel{LF_i \cdot LMP_E} + \sum_{l=1}^L GSF_{l,i} \cdot SP_l,$$

Disregard losses

Reference Bus

LMPs will not change if we move the reference bus location

- Both **loss** and **congestion** components are always zero at the reference bus
- Price at the reference bus is always equal to the **energy component**
- All components are dependent on the selection of the reference bus
 - Due to the dependency of the sensitivities on the location of the reference bus



LMP Components

Purpose: Determine how much of the Δ LMP between two points is due to either

- Losses
- Congestion



LMP Components (with a Binding Constraint, Ref = Bus A)

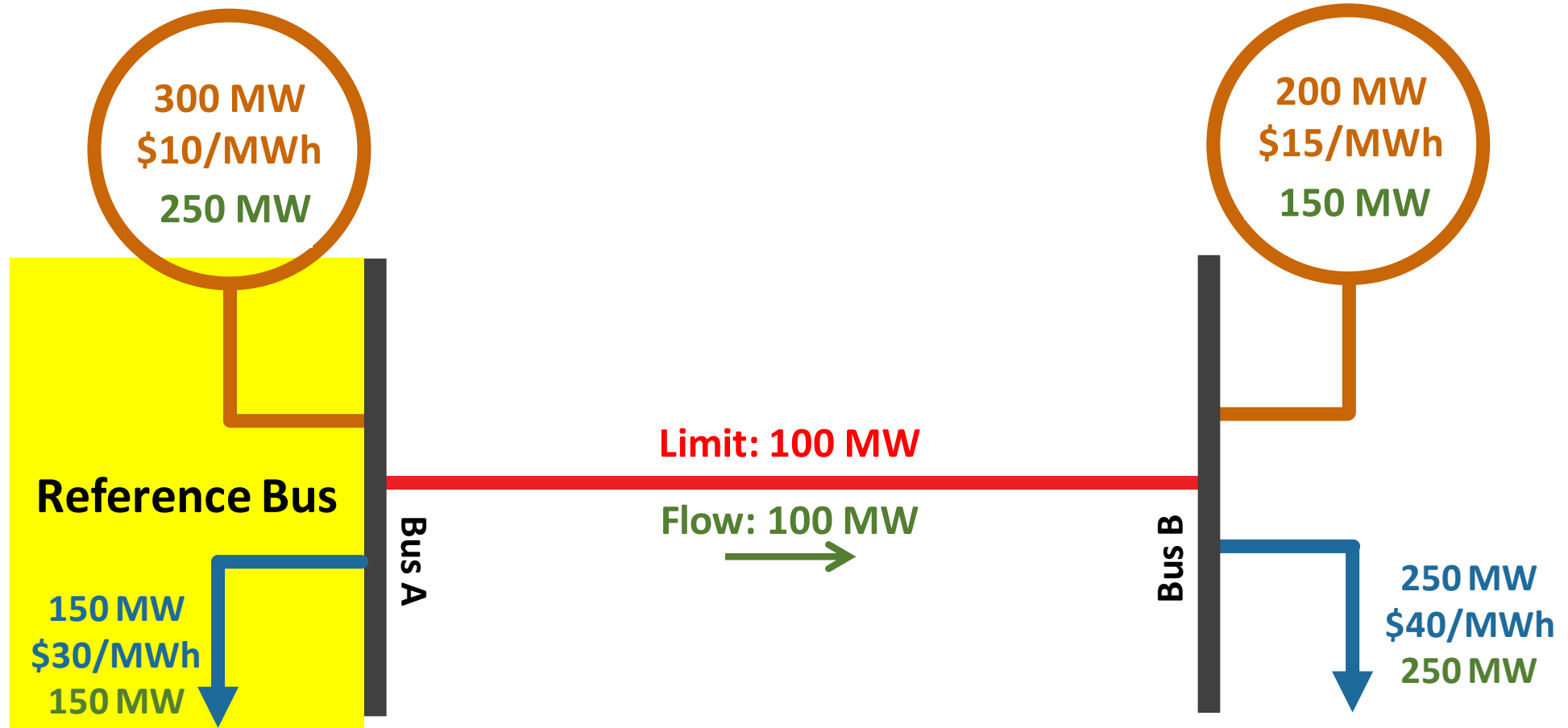

$$\begin{array}{l}
 \text{Energy Price} = \$10/\text{MWh} \\
 + \text{Congestion}_A = 0 \\
 + \text{Loss}_A = 0 \\
 \hline
 \text{LMP}_A = \$10/\text{MWh}
 \end{array}$$

$$\begin{array}{l}
 \text{Energy Price} = \$10/\text{MWh} \\
 + \text{Congestion}_B = \$5/\text{MWh} \\
 + \text{Loss}_B = 0 \\
 \hline
 \text{LMP}_B = \$15/\text{MWh}
 \end{array}$$

LMP Components (with a Binding Constraint, Ref = Bus B)

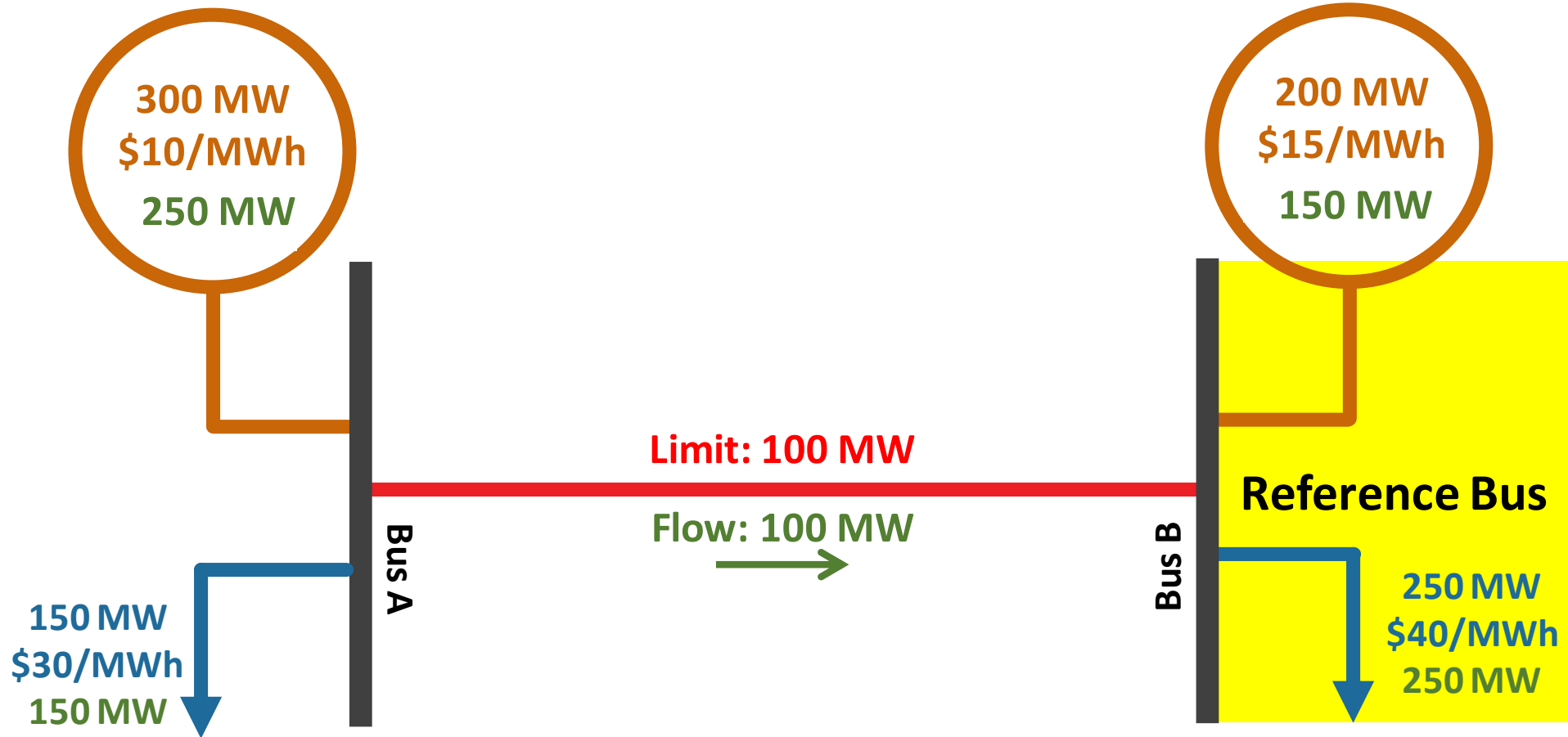

$$\begin{aligned}
 & \text{Energy Price} = \$15/\text{MWh} \\
 + & \text{Congestion}_A = \$-5/\text{MWh} \\
 + & \text{Loss}_A = 0 \\
 \hline
 & \text{LMP}_A = \$10/\text{MWh}
 \end{aligned}$$

$$\begin{aligned}
 & \text{Energy Price} = \$15/\text{MWh} \\
 + & \text{Congestion}_B = 0 \\
 + & \text{Loss}_B = 0 \\
 \hline
 & \text{LMP}_B = \$15/\text{MWh}
 \end{aligned}$$



Questions?

Bidding Decisions and Possible Impacts

How demand bids and supply offers interact with other inputs to impact the day-ahead market LMPs



Buying from ISO Energy Market



Clearing Fixed-Demand Bids

- Bids are submitted at the zones
- Software distributes the amount bid to each of the load nodes within the zone pro rata to the 7-day average nodal weighting
- Software attempts to re-dispatch without regard to cost to meet fixed demand
 - This re-dispatch can create extremely high LMPs in local areas
- Nodal LMP can far exceed bid caps and offer caps because there is no cost associated with fixed demand bid
- A small amount of “fixed” load at a location may impact the nodal price dramatically

Clearing Price-Sensitive Demand Bids

- Bids are submitted at:
 - Zones
 - Nodes
- Software distributes zonal bids to the nodes
 - Using same weighting as fixed bids
- These bids will lessen the impact of nodal constraints
- If bid at the zone, individual nodes may exceed the bid price but the zonal price will not exceed bid
 - Depending on the bid price and nodal weighting, an individual node LMP may still exceed bid caps or offer caps



Selling to the ISO Energy Market



Clearing Fixed Supply Offers – Self-Scheduled (SS)

- Offers are submitted by generators
- Software attempts to re-dispatch without regard to cost to clear fixed supply offers
 - This re-dispatch can create extremely low LMPs in local areas
- Nodal LMP can become negative because there is no cost associated with fixed supply offer
- A small change in the amount of “fixed” generation at a location may impact the nodal price dramatically

Extremes in LMPs

LMP extremes are caused by combinations of a variety of items:

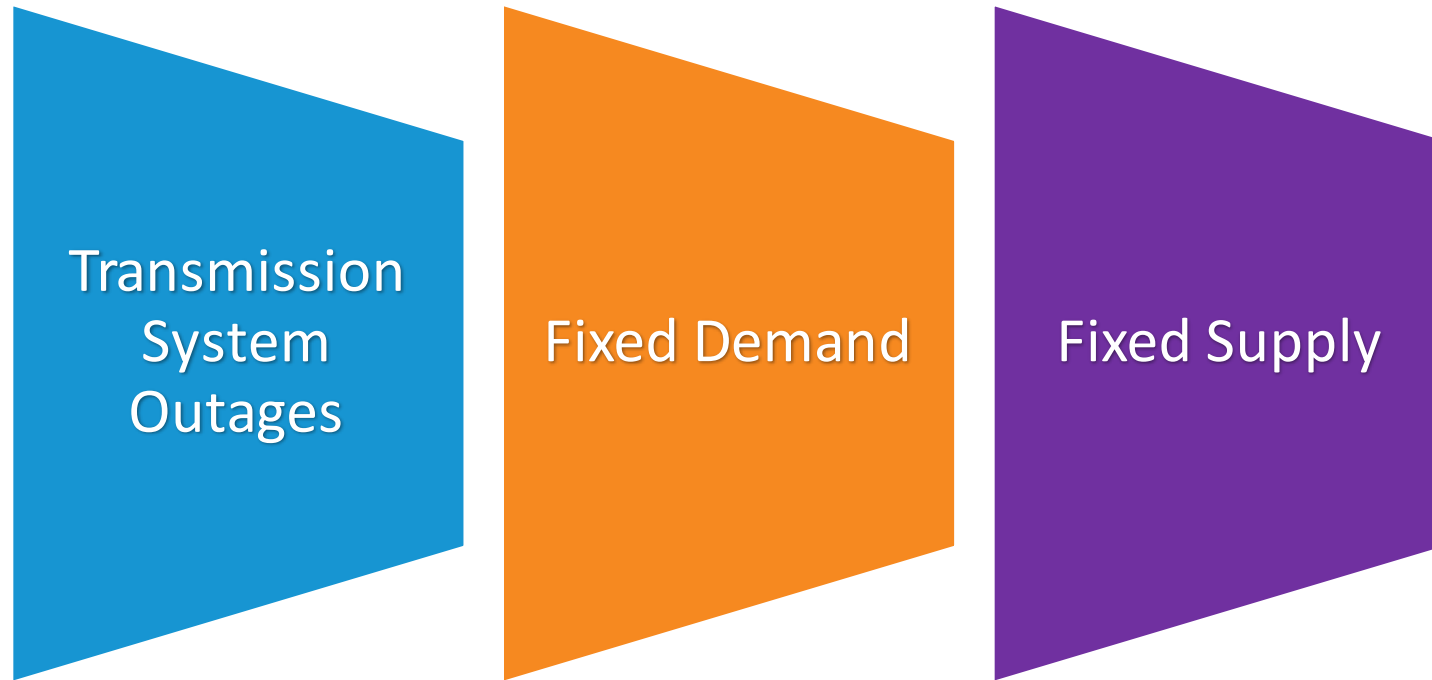

Ex8_FourLocations_ExtremePrices

Summary

In this module, you have learned about the following:

- Sensitivities (PTDF)
- How to use a sensitivity (PTDF)
- Using a PTDF to calculate prices
- Inputs to LMPs
- How high prices occur
- How low prices occur
- What “social surplus” is and how it is used

Contact Participant Support and Solutions



Submit a request via Ask ISO *(preferred)*
<https://askiso.force.com/>

Email AskISO@iso-ne.com

Phone

(413) 540-4220 (call center)

(833) 248-4220

Pager *(for emergency inquiries outside of business hours)*

(877) 226-4814

**Business hours and
additional contact details
are available from the
Participant Support page**

[Visit the Participant Support page](#)

Appendix



Power System: 4 Node

Introduction

Generator offers:
[Min-Max MW@\$ /MWh]

Generator merit order

G1:	0 - 250MW @	\$0/MWh
G5:	100 - 200MW @	\$20/MWh
G2:	100 - 150MW @	\$30/MWh
G6:	50 - 130MW @	\$50/MWh
G3:	300 - 600MW @	\$60/MWh
G4:	0 - 100MW @	\$125/MWh

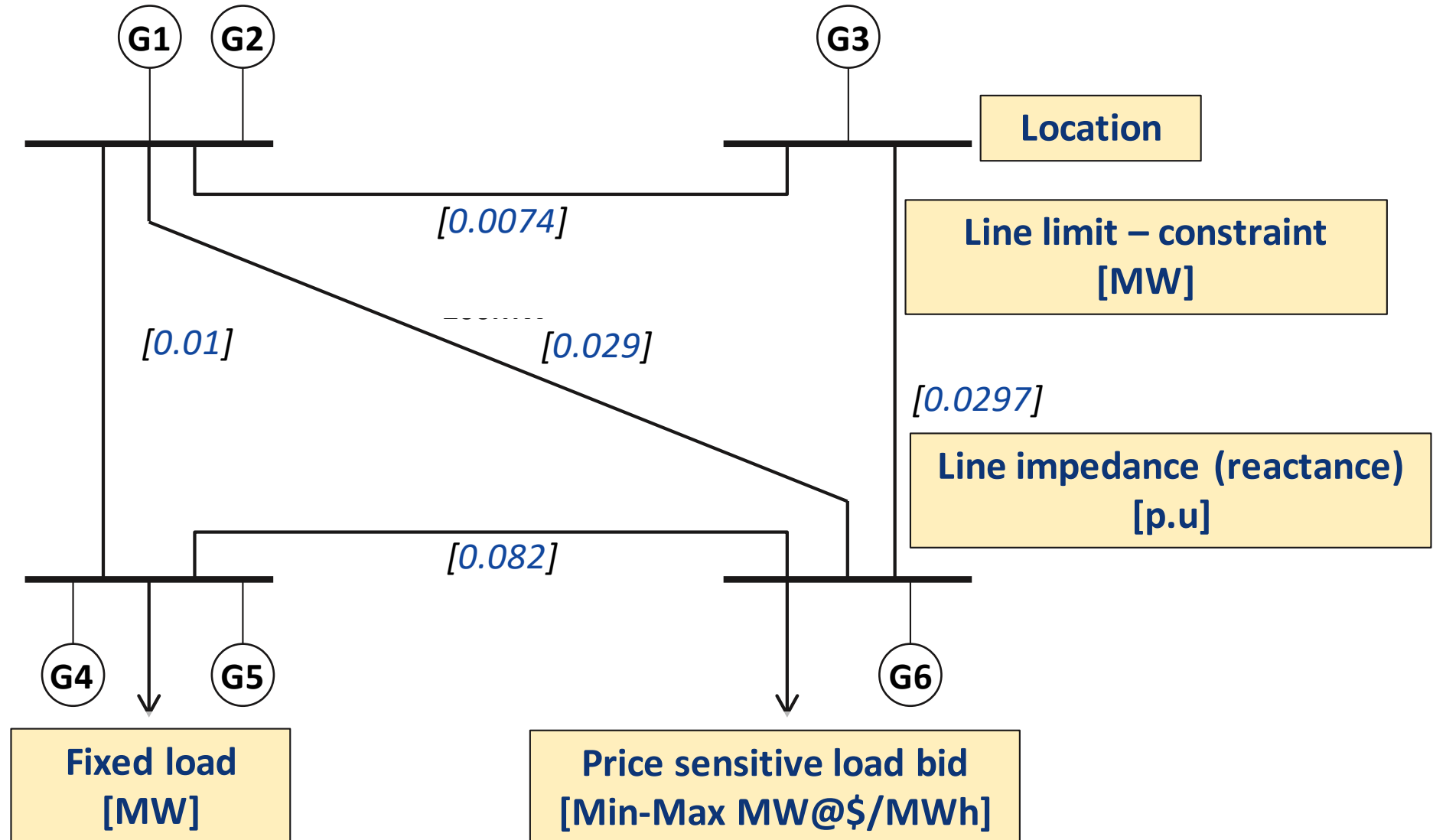

Fixed load
[MW]

Price sensitive load bid
[Min-Max MW@\$ /MWh]

Location

Line limit – constraint
[MW]

[0.0297]

Line impedance (reactance)
[p.u]

Fixed Demand Bid

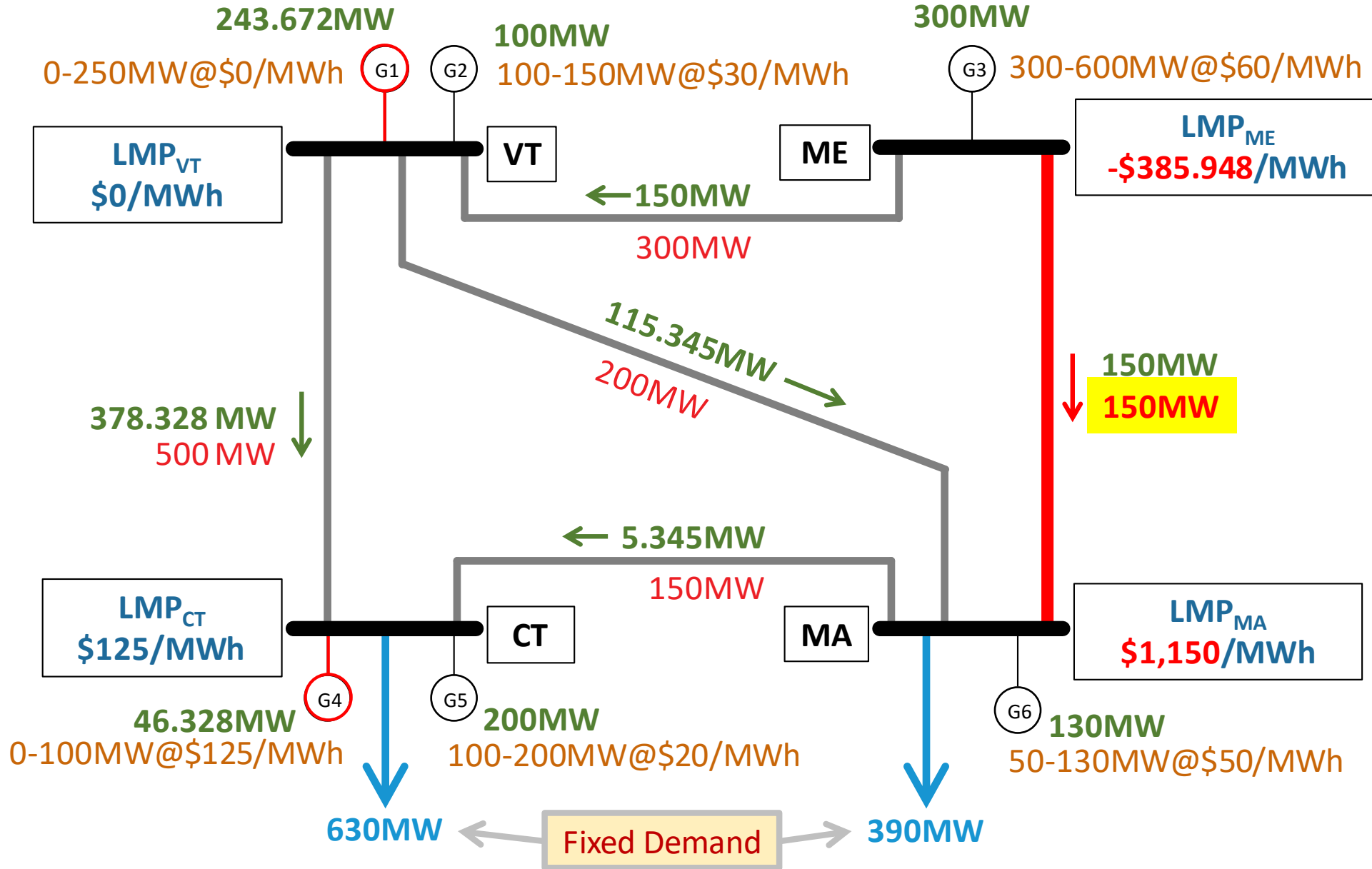

Clearing of DAM

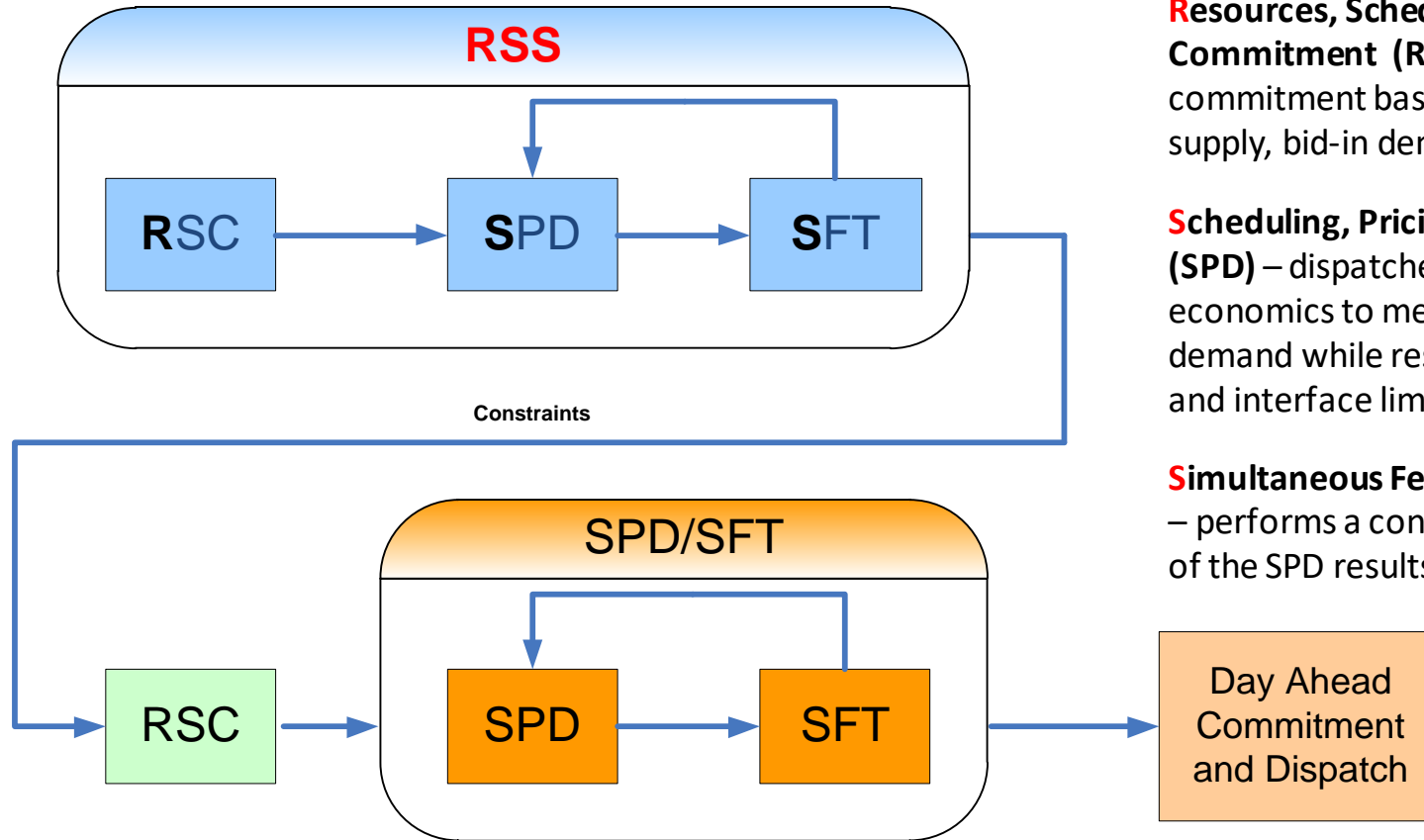

Resources, Scheduling and Commitment (RSC) – develops unit commitment based on offered supply, bid-in demand and reserves

Scheduling, Pricing and Dispatch (SPD) – dispatches units in economics to meet the cleared demand while respecting the line and interface limits.

Simultaneous Feasibility Test (SFT) – performs a contingency analysis of the SPD results

Day Ahead
Commitment
and Dispatch

GSF – Exercise

- Determine GSF for line **C-A**, in regard to all locations
- Calculate all PTDF for line C-A
- All three lines are identical
- Reference bus = **B**

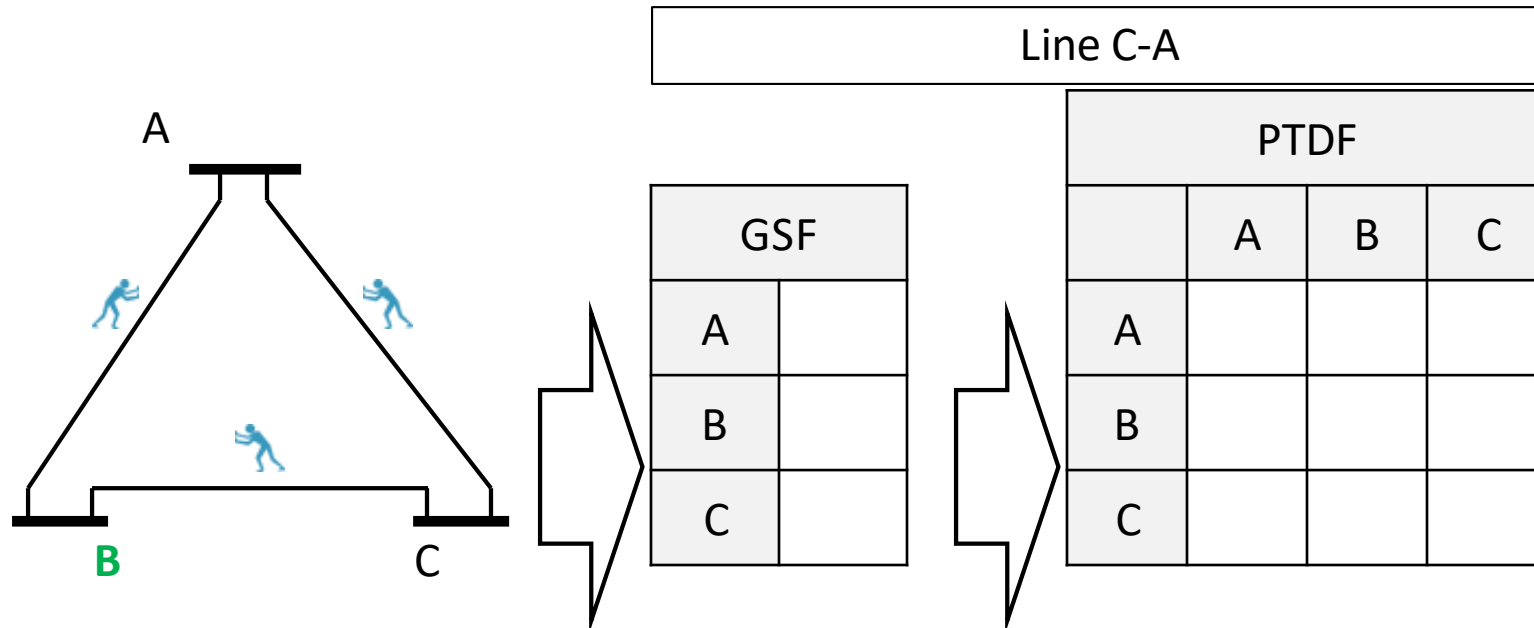

GSF – Solution

- Determine GSF for line **C-A**, in regard to all locations
- Calculate all PTDF for line C-A
- All three lines are identical
- Reference bus = **B**

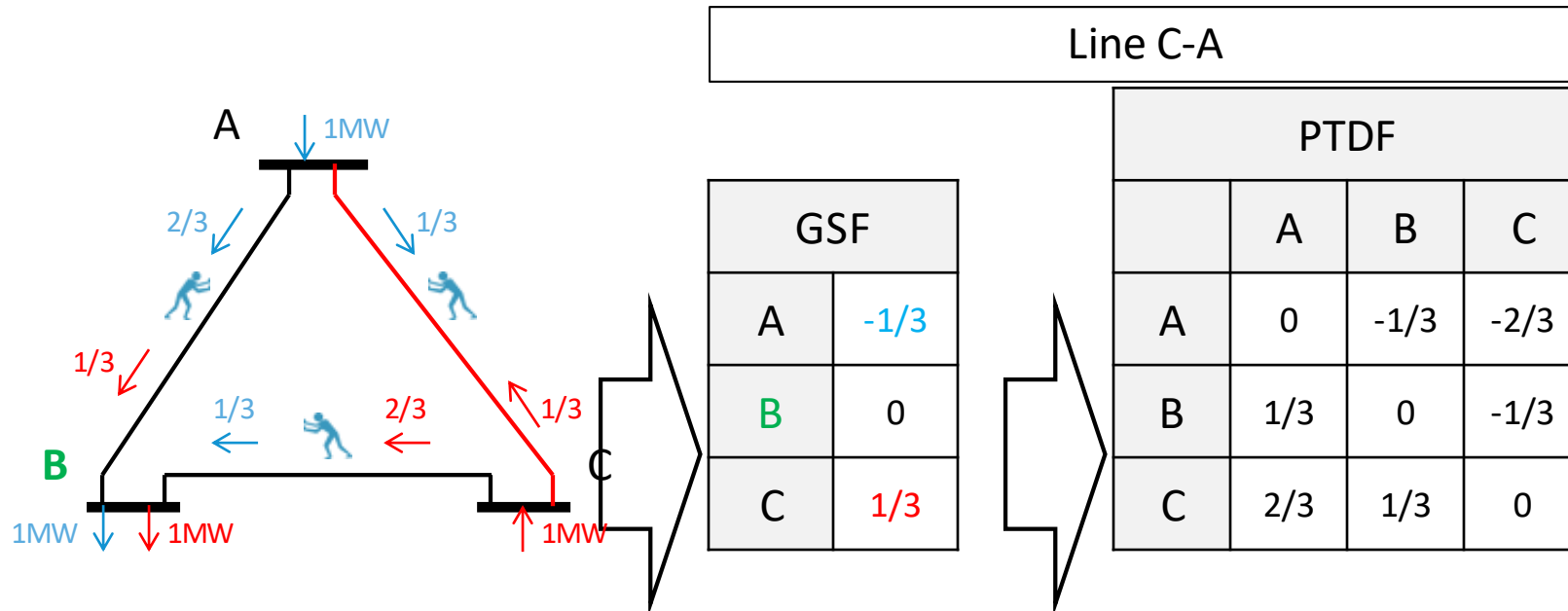

LMP Math

- Additional 1 MW of load in MA will be served re-dispatching (changing output) of marginal units (G_1 in VT and G_4 in CT)

$$q_{VT} + q_{CT} = 1$$

- 37.28% of power from VT will flow over constrained line (PTDF = 0.3728)
- 33.23% of power from CT will flow over constrained line (PTDF = 0.3323)
- Flow on constrained line cannot change

$$0.37278 \cdot q_{VT} + 0.33226 \cdot q_{CT} = 0$$

- LMP in MA is equal to the cost of producing this additional 1 MW of power

$$LMP_{MA} = 0 \cdot q_{VT} + 125 \cdot q_{CT}$$

Mathematical Explanation

Using PTDFs to Calculate Negative LMP (ME)

- Additional 1 MW of load in ME will be served re-dispatching (changing output) of marginal units (G_1 in VT and G_4 in CT)

$$q_{VT} + q_{CT} = 1$$

- -12.51% of power from VT will flow over constrained line (PTDF = -0.1251)
- -16.56% of power from CT will flow over constrained line (PTDF = -0.1656)
- Flow on constrained line (ME-MA) can not change

$$-0.12511 \cdot q_{VT} - 0.16563 \cdot q_{CT} = 0$$

- LMP in MA is equal to the cost of producing this additional 1 MW of power

$$LMP_{MA} = 0 \cdot q_{VT} + 125 \cdot q_{CT}$$

GSF and PTDF Compared

System size L = # of constrained lines N = # of nodes in the system	Assume L = 10 N = 1,000
--	--------------------------------------

PTDF	GSF
Total number of PTDFs $= L \times N \times (N - 1) \div 2$ $= 10 \times 1,000 \times (1,000 - 1) \div 2$ $= \mathbf{4,995,000}$	Total number of GSFs $= L \times (N - 1)$ $= 10 \times (1,000 - 1)$ $= \mathbf{9,990}$

LMP Calculation

LMP at any location is calculated based on the shadow prices out of LP solution.

The following formula is used to calculate LMPs for any node i :

$$LMP_i = LMP_E - LF_i \cdot LMP_E + \sum_{k=1}^K GSF_{k,i} \cdot SP_k,$$

Term	Description
LMP_E	Shadow price of the system balance constraint for delivery at the reference bus
LF_i	Loss factor for node i
$GSF_{k,i}$	GSF of line k , for delivery from node i (to reference bus)
SP_k	Shadow price of transmission constraint on line k

Determining Shadow Price of Constraint

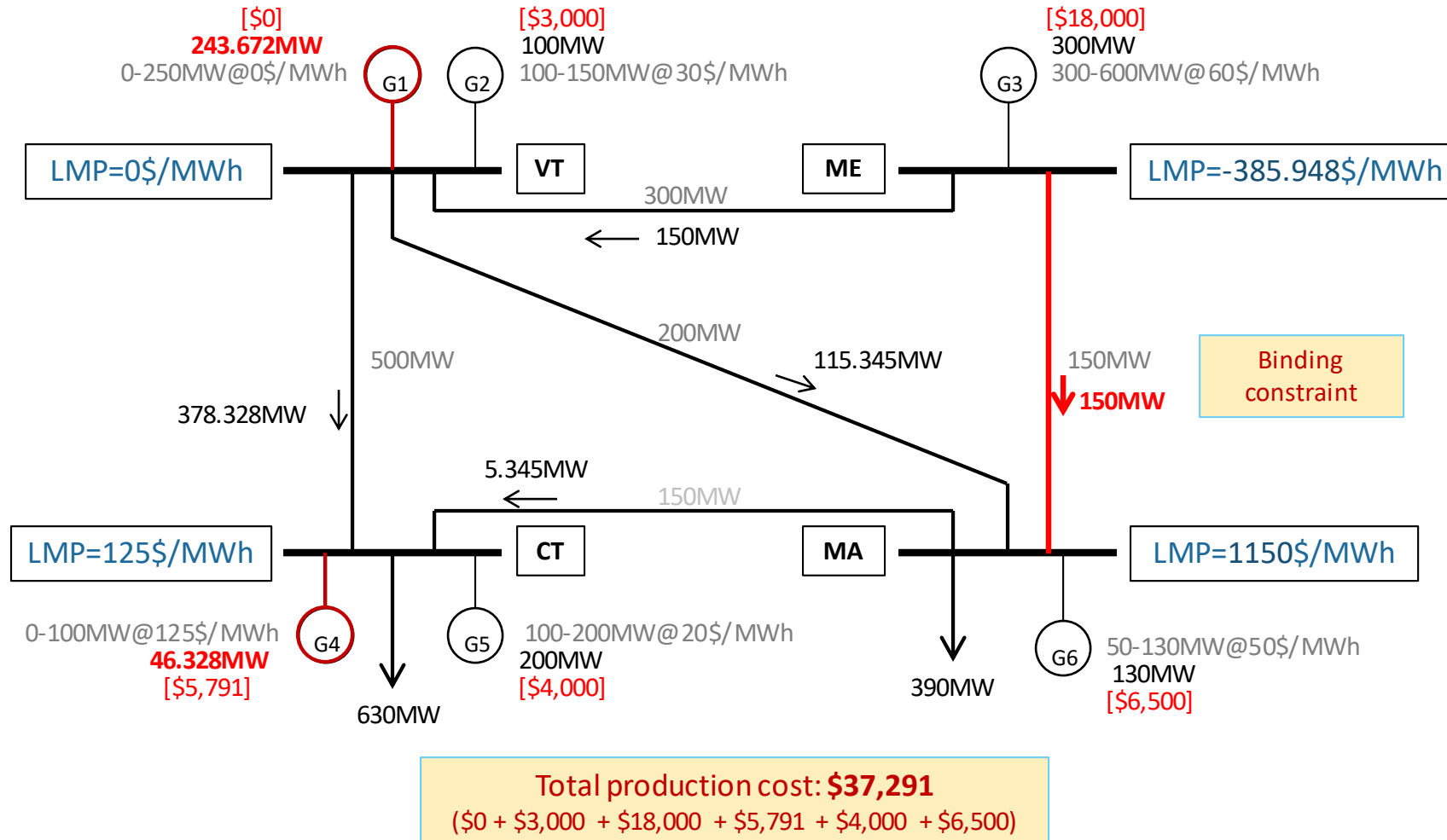

Determining Shadow Price of Constraint, *continued*

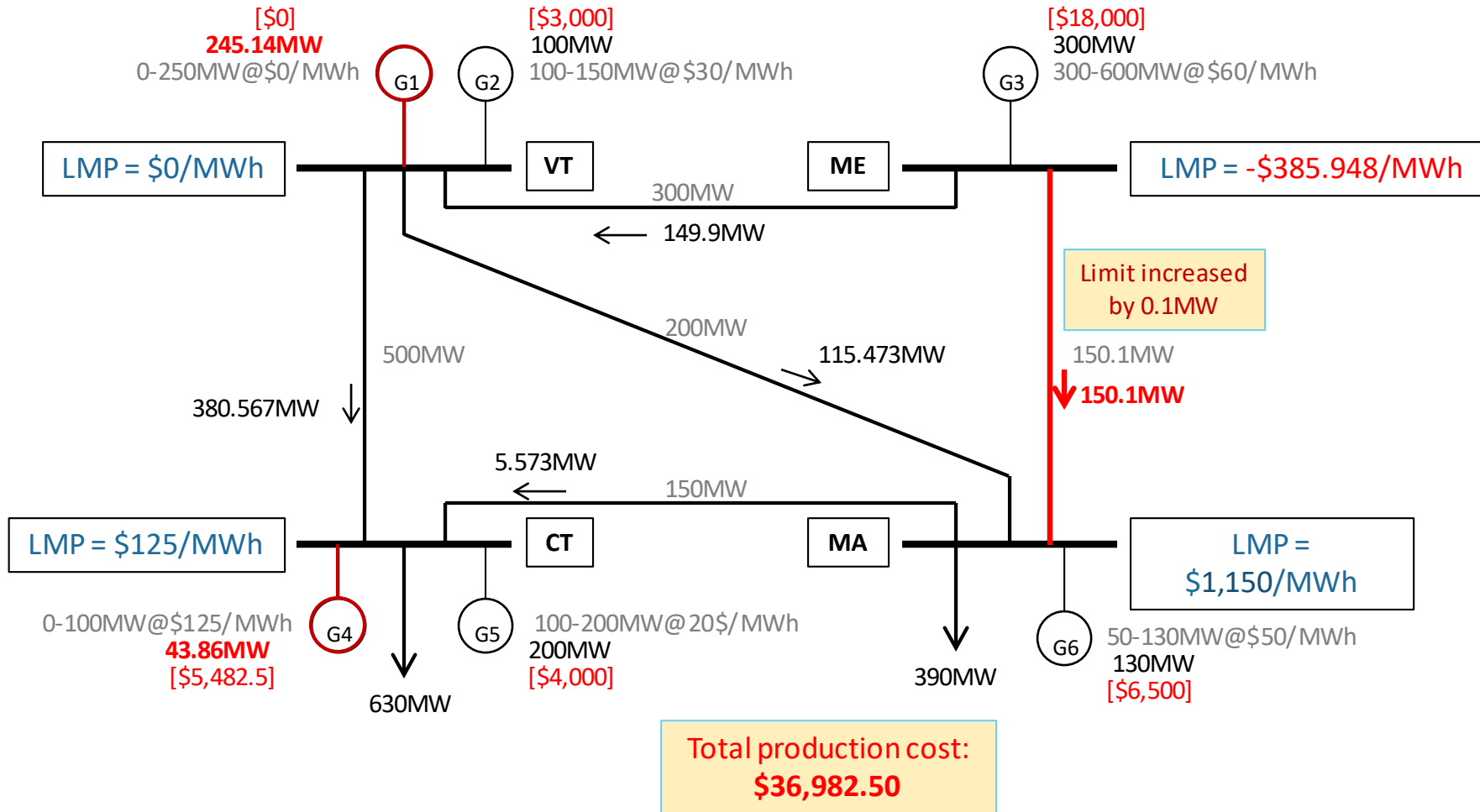

Determining Shadow Price of Constraint, *continued*

- By increasing the limit on line ME-MA by 0.1 MW
 - Total production cost is lowered by $-\$308.50$
 - Which is $-\$3,085/\text{MWh}$
- Relaxing the constraint on line ME-MA would cause a total production cost change of $-\$3,085/\text{MWh}$, the shadow price of this constraint

LMP Calculation Using Shadow Price

Let's try to replace the values in the equation by using the previously calculated shadow price (SP_k) of constraint

$$LMP_i = LMP_E - \cancel{LF_i \cdot LMP_E} + \sum_{k=1}^K GSF_{k,i} \cdot SP_k,$$

Disregard losses

$$LMP_{MA} = LMP_{CT} + GSF_{ME-MA,MA} \cdot SP_{ME-MA} = 125 + (-0.33226) \cdot (-3085)$$

$$LMP_{MA} = \$1,150/\text{MWh}$$

LMP Calculation for All Locations

Location	LMP @ Ref	Shift Factor (GSF)	Shadow Price of Constraint	LMP
ME	125	0.16563	-3,085	-386
MA	125	-0.33226	-3,085	1150
VT	125	0.04052	-3,085	0
CT	125	0.00000	-3,085	125

GSF Example

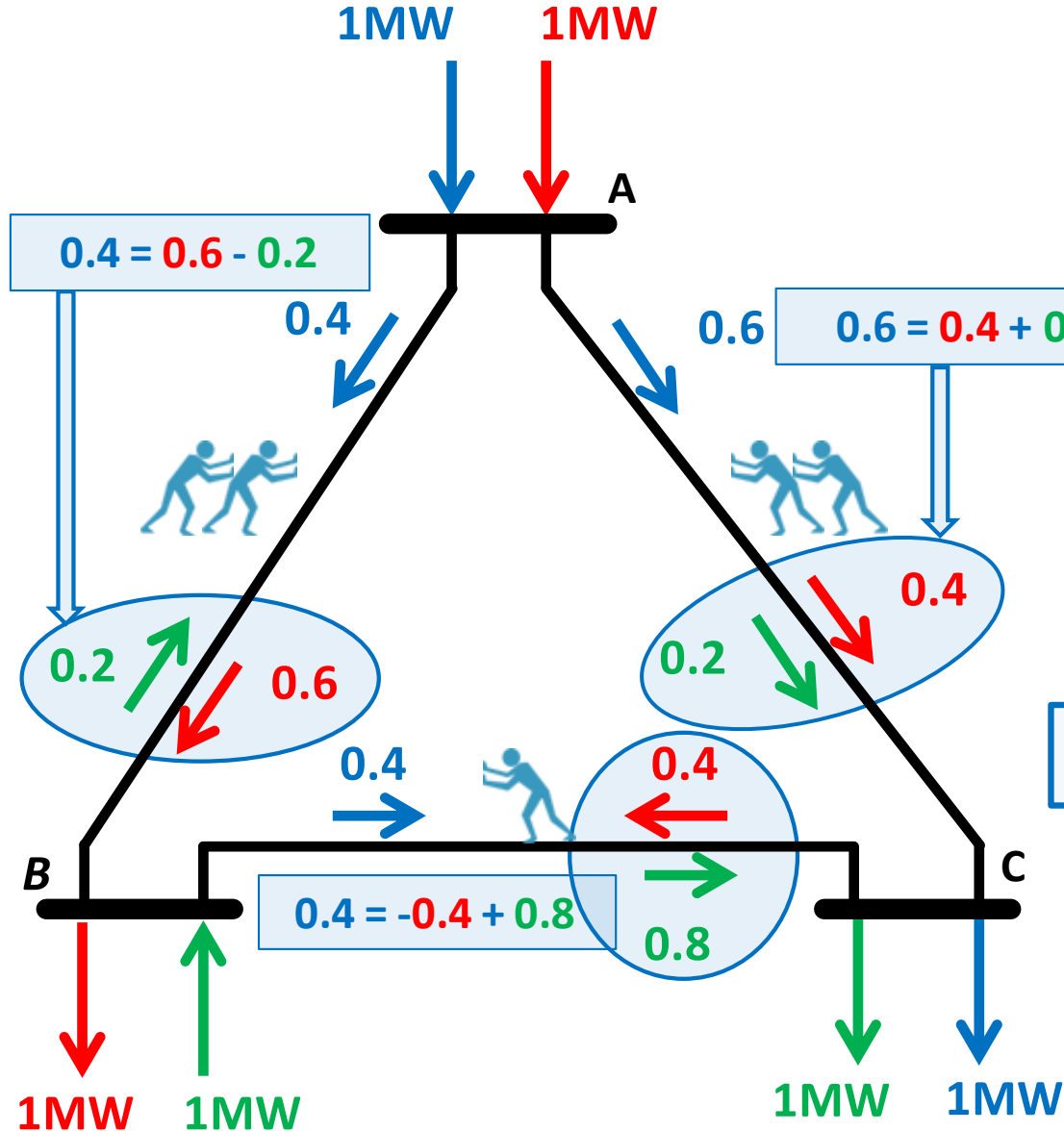

For any line:
 $PTDF^{A-C} = PTDF^{A-B} + PTDF^{B-C}$

When source or destination is a reference location PTDF becomes GSF

$PTDF^{N-Ref} = GSF^N$
 $PTDF^{Ref-N} = -GSF^N$

$PTDF^{A-C} = GSF^A - GSF^C$

LMP Components

$$LMP_i = \underbrace{LMP_E}_{\text{Energy Component}} - \underbrace{(LF_i \times LMP_E)}_{\text{Loss Component}} + \underbrace{\left(\sum_{k=1}^K GSF_{k,i} \times SP_k \right)}_{\text{Congestion Component}}$$

- To determine all LMPs, use the generator shift factors ($GSF_{k,i}$ above) and the shadow price of the ME-MA constraint (SP_k above)
- What is the shadow price of the constraint?

LMP Calculation Using Shadow Price

Let's try to replace the values in the equation by using the previously calculated shadow price (SP_k) of constraint

$$LMP_i = LMP_E - \cancel{LF_i \cdot LMP_E} + \sum_{k=1}^K GSF_{k,i} \cdot SP_k,$$

Location	LMP @ Ref	Shift Factor (GSF)	Shadow Price of Constraint	LMP
ME	125	0.16563	-3,085	-386
MA	125	-0.33226	-3,085	1150
VT	125	0.04052	-3,085	0
CT	125	0	-3,085	125

Binding Constraint \Rightarrow Shadow Price

