



Final 2026 DER Forecast



Outline

- [Introduction](#)
- [Final 2026 DER Nameplate Forecast](#)
- [Classification of DER Forecast – Results](#)
- [2026 BTM DER Energy Forecast](#)
- [2026 BTM DER Peak Demand Reductions](#)
- **Appendix:**
 - [Appendix I: 2025 DER Interconnection Data Update](#)
 - [Appendix II: 2026 DER Forecast Assumptions](#)
 - [Appendix III: Forecast Inputs and Discount Factors](#)
 - [Appendix IV: 2026 DER County-level Forecast](#)
 - [Appendix V: 2026 DER Scenario Forecast](#)
 - [Appendix VI: Classification of DER Forecast – Background and Methods](#)
 - [Appendix VII: BTM DER Energy Forecast – Background and Methods](#)
 - [Appendix VIII: DER BESS Hourly Modeling Methodology](#)
 - [Appendix IX: DER PV End-of-life Accounting](#)



Forecast Review Process



- The ISO hosted 4 Distributed Generation Forecast Working Group (DGFWG) meetings during the 2026 forecast cycle:
 1. October 24, 2025
 - [DER forecast enhancements](#)
 2. December 8, 2025
 - [DER forecast updates](#)
 3. February 9, 2026
 - [Draft 2026 PV forecast](#)
 4. March 23, 2026
 - [Final 2026 PV forecast](#)
- The final PV forecast is published in the 2026 CELT (Section 3):
 - See: <https://www.iso-ne.com/system-planning/system-plans-studies/celt/>

INTRODUCTION



Introduction

- A significant amount of state-sponsored distributed energy resource (DER) do not participate in wholesale markets, but have impacts on system load observed by the ISO
- The long-term DER forecast helps the ISO determine future system load characteristics that are important for the reliable planning and operation of the system
- The 2026 DER forecast includes DER battery energy storage systems (BESS) that are co-located with rooftop DER PV
- To properly account for DER PV in long-term planning, the finalized PV portion of the forecast will be categorized as follows:
 1. DER in the Forward Capacity Market (FCM)
 2. Non-FCM Energy Only Resources (EOR) and Generators
 3. Behind-the-meter (BTM)
- The scope of the DER BESS forecast focuses exclusively on systems co-located with rooftop PV that are < 1 MW in nameplate capacity
 - Intended to represent a small portion of overall DER BESS growth that does not participate in wholesale markets, and is categorized as BTM in the ISO's forecast

Behind-the-meter PV is reconstituted into historical loads*

The 2026 gross load forecast reflects loads without PV load reductions

**Historical BTM PV reduces historical metered loads; historical loads reconstituted for BTMPV are used to model base load in developing the base load forecast. All historical BTM BESS impacts are reflected in historical loads.*

DER Forecast Focuses on Distributed Generation

- The focus of the DGFWG is distributed generation (DG) projects:
 - “...defined as those that are typically 5 MW or less in nameplate capacity and are interconnected to the distribution system (typically 69 kV or below) according to state-jurisdictional interconnection standards.”
 - Note that the industry has evolved since the formation of the DGFWG, and today DG is often referred to as a distributed energy resource (DER)
 - Per the ISO’s [Planning Procedure 12](#), DER is defined as *any generator or energy storage facility located on the distribution system, any subsystem thereof, or behind a customer meter that is capable of providing energy injection, energy withdrawal, regulation or demand reduction*
 - DER does not include demand response, controllable loads, or other load modifiers
- While DER may include larger-scale DER projects greater than 5 MW in size, the forecast does not consider policy drivers and growth of larger-scale DER projects, since these projects are generally accounted for as part of the ISO’s interconnection process and participate in wholesale markets (i.e., they are not BTM)

DER Forecast Methodology

- The DER forecast is a projection of distributed energy resources to be used in ISO-NE System Planning studies
- Development of the DER forecast includes use of the Distributed Generation Market Demand Model (dGen™), an agent-based simulation platform developed and open-sourced by the National Renewable Energy Laboratory (NREL)
 - An overview of the dGen™ model was presented by the NREL team at the [October 2023 DGFWG meeting](#)
- The nameplate forecast is developed using the two following additive processes:
 1. For < 1 MW systems (both PV and BESS): Use residential and commercial dGen™ modeling
 2. For 1-5 MW systems (PV only): Use a policy-based approach
- The DER forecast is developed out through 2050

DER Forecast Inputs

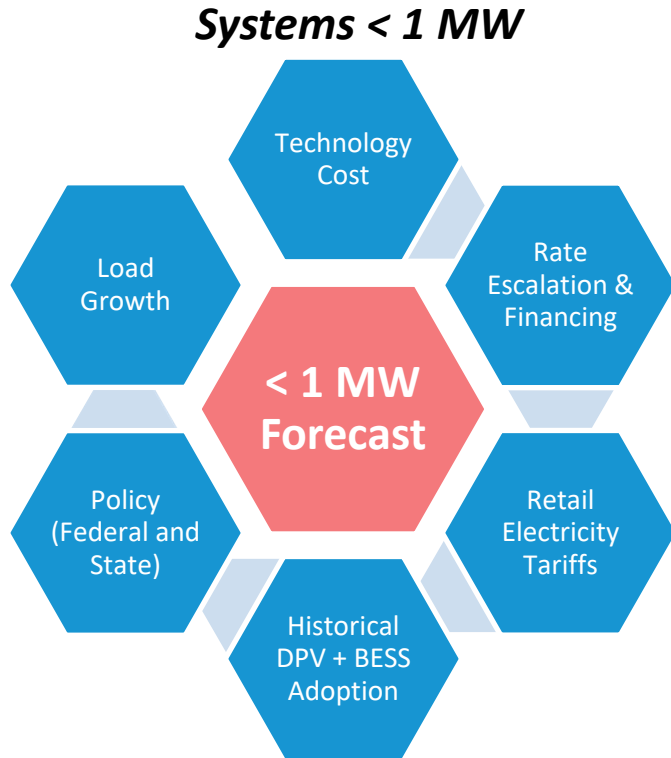

**Systems 1-5 MW
(PV Only)**

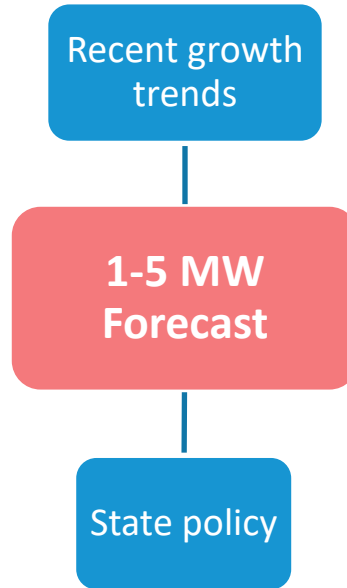

CELT 2026 DER Forecast Process Flow

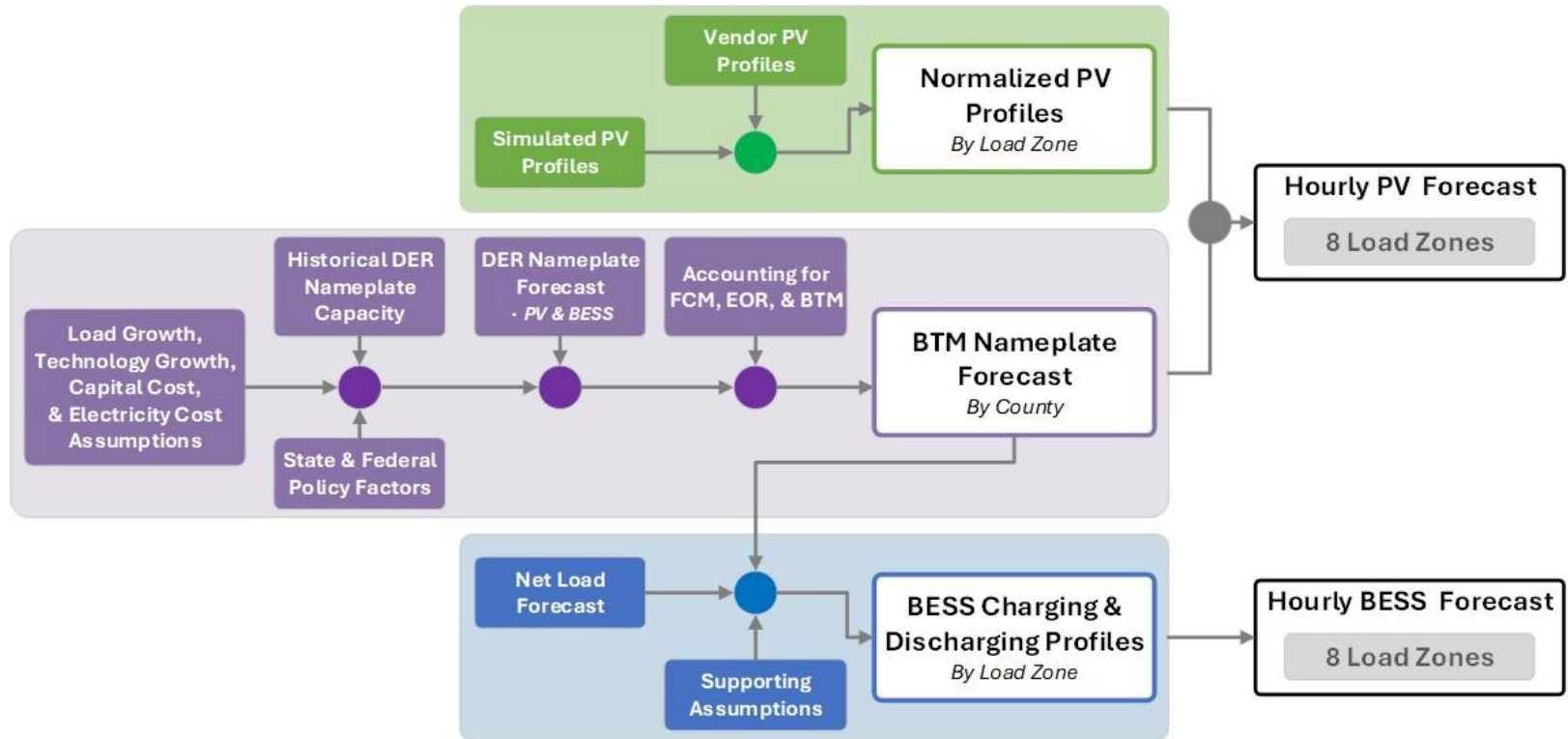

2026 DER PV Forecast Improvements

- For CELT 2026, the ISO implemented the following improvements:
 1. DER battery energy storage system forecast (BESS)
 - Refer to next slide
 2. DER scenario forecast
 - Details of the DER scenario forecast are included in [Appendix V](#)
 3. Accounting for DER PV end-of-life (EOL)
 - Details of the DER PV end-of-life accounting are included in [Appendix IX](#)

DER BESS Forecast

- The ISO developed its first DER BESS forecast as part of CELT 2026
- The DER BESS nameplate adoption forecast represents anticipated future incremental growth of behind-the-meter (BTM) batteries that are co-located with residential and commercial rooftop PV
 - Refer to [slide 7](#) for a high-level description of the nameplate forecast methodology
- The hourly profiling of BESS charging/discharging is designed to represent the effects of retail-based peak shaving strategies on regional load
 - Refer to [Appendix VIII](#) for a description of the hourly profiling methodology
- Hourly BTM BESS profiles are used in tandem with other load component profiles that comprise the long-term load forecast
 - Other components include base load, electric vehicles, heat pumps, large loads, and BTM PV

FINAL 2026 DER NAMEPLATE CAPACITY FORECAST

Final 2026 DER PV Forecast – 10 Year Horizon

Nameplate Capacity, MW_{ac}

States	Annual Total MW (AC nameplate rating)											Totals
	Thru 2025	2026	2027	2028	2029	2030	2031	2032	2033	2034	2035	
CT	1,458	155	139	117	89	79	74	74	78	77	78	2,419
MA	4,286	312	325	310	233	162	100	97	107	111	116	6,160
ME	1,181	56	50	41	39	39	40	41	42	42	42	1,615
NH	333	33	35	34	30	27	26	27	30	32	34	639
RI	504	54	49	44	39	34	32	31	30	30	29	876
VT	597	45	43	39	37	37	33	33	32	31	32	960
Regional - Cumulative (MW)	8,359	9,013	9,655	10,241	10,707	11,085	11,389	11,694	12,013	12,337	12,669	12,669

Notes:

- (1) Forecast values include FCM Resources, non-FCM Energy Only Generators, and behind-the-meter PV resources
- (2) The forecast values are net of the effects of discount factors applied to reflect uncertainty in policies, as well as end-of-life accounting
- (3) All values represent end-of-year installed capacities
- (4) Forecast does not include forward-looking PV projects > 5MW in nameplate capacity

Regional PV Nameplate Capacity Growth

Historical vs. Forecast

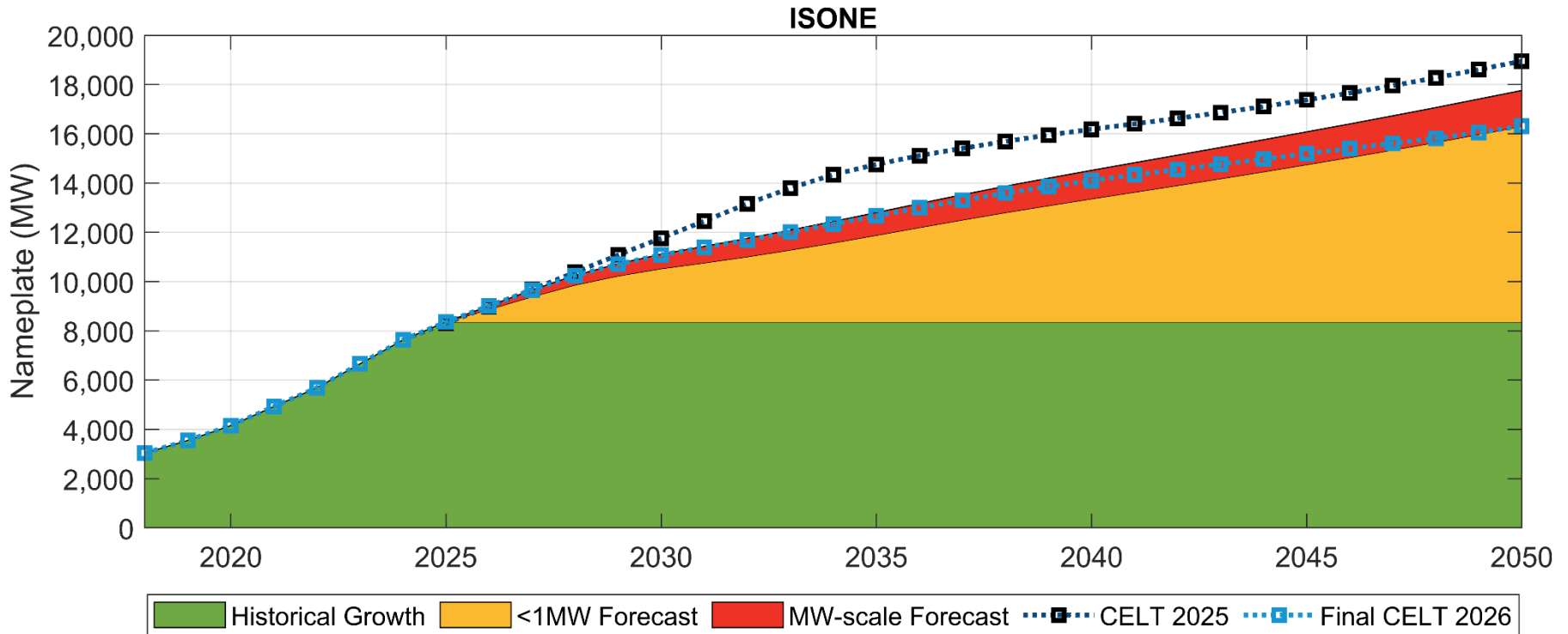

State PV Nameplate Capacity Growth

Historical and Forecast

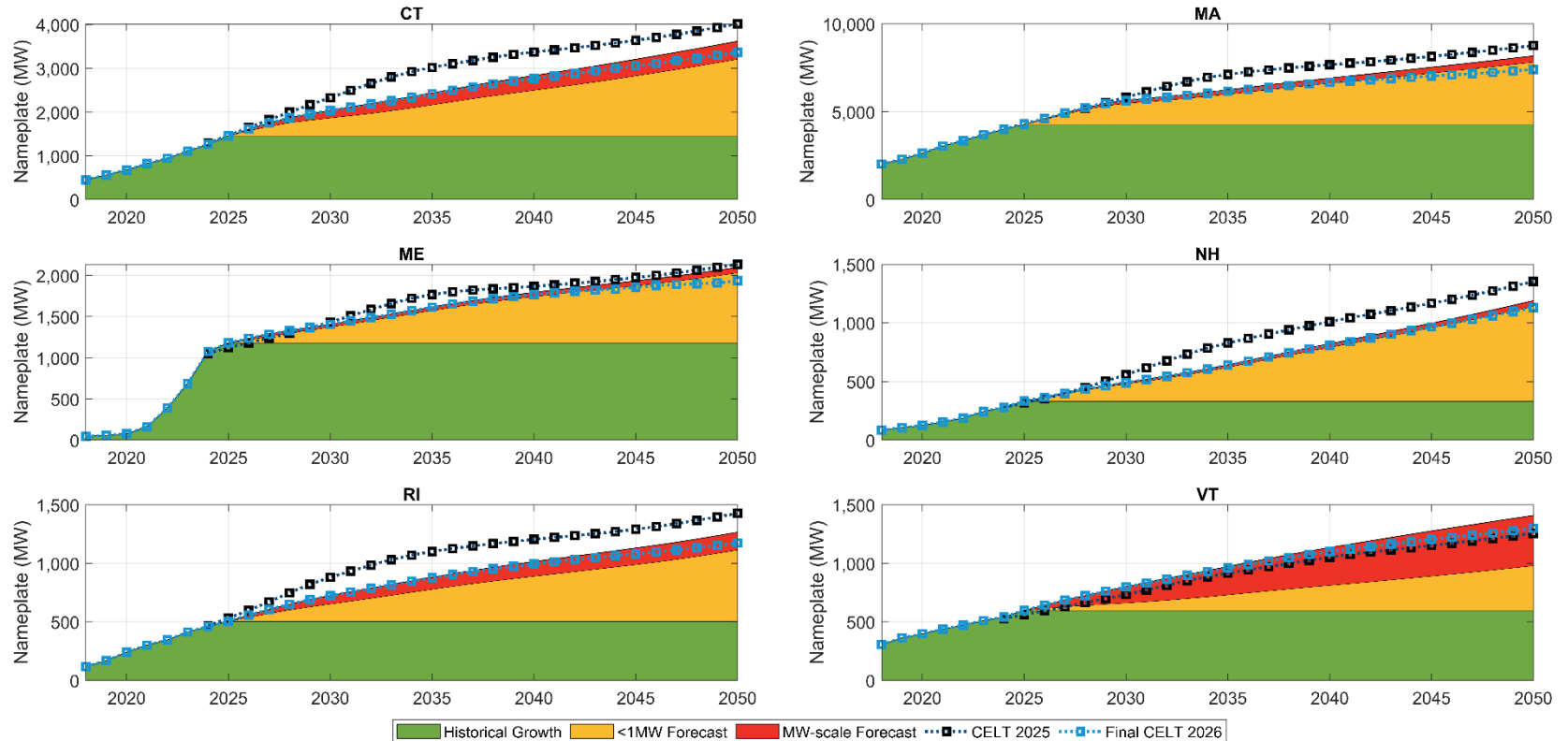

Final 2026 DER BESS Forecast – 10-Year Horizon

Nameplate Capacity, MW_{ac}

States	Annual Total MW (AC nameplate rating)										Totals
	2026	2027	2028	2029	2030	2031	2032	2033	2034	2035	
CT	6.0	6.4	6.3	4.2	2.1	0.0	0.0	0.0	0.0	0.5	25.4
MA	20.3	28.8	34.2	26.2	13.1	0.2	0.5	0.8	0.9	1.1	126.1
ME	1.4	1.5	1.5	1.0	0.5	0.1	0.2	0.2	0.1	0.1	6.4
NH	0.7	0.9	0.9	0.6	0.3	0.0	0.0	0.1	0.1	0.2	3.7
RI	0.3	0.4	0.8	0.7	0.4	0.0	0.0	0.0	0.0	0.0	2.6
VT	2.2	1.7	1.2	0.7	0.6	0.5	0.5	0.4	0.4	0.4	8.5
Regional - Cumulative (MW)	30.8	70.3	115.2	148.5	165.5	166.3	167.5	169.0	170.6	172.8	172.8

Notes:

- (1) The forecast values are net of discount factors
- (2) All values represent end-of-year installed capacities

Regional BESS Nameplate Capacity Growth Forecast

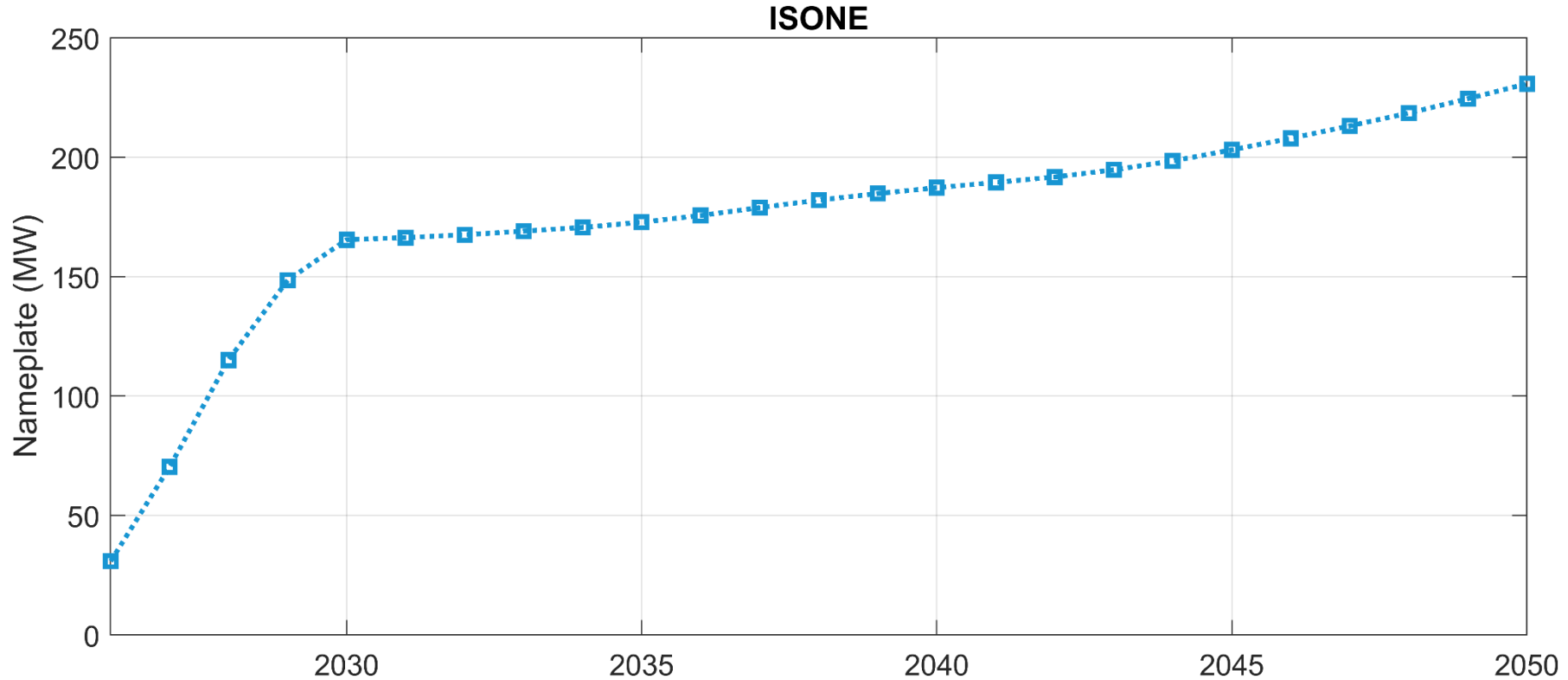

State BESS Nameplate Capacity Growth Forecast

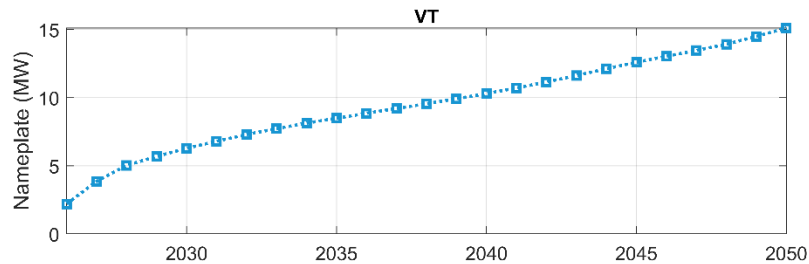
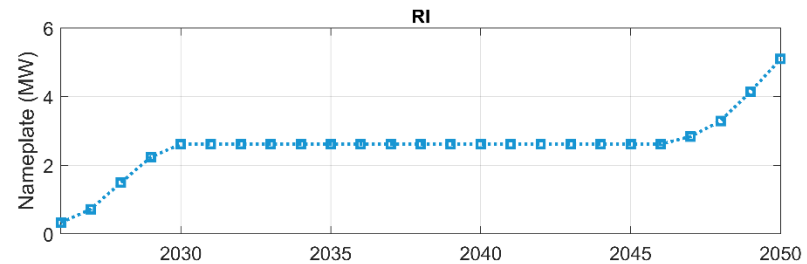
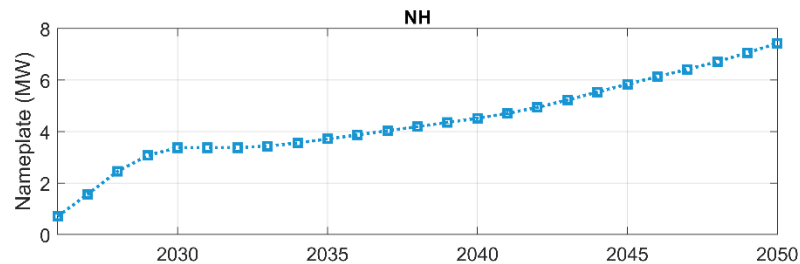
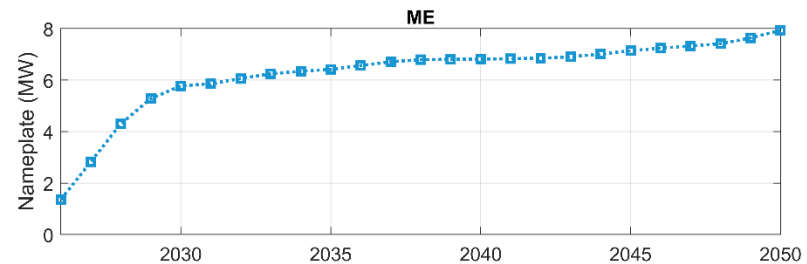
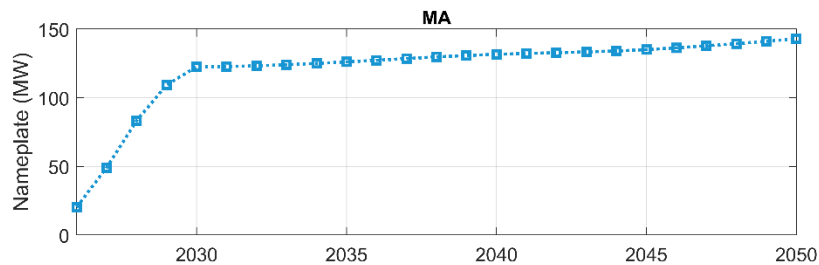
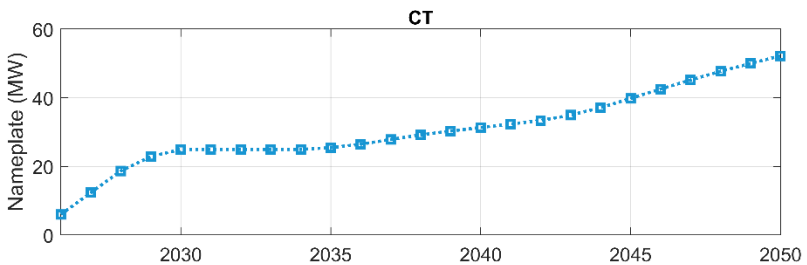

Development of County-Level Forecasts

- County-level DER forecast for systems with nameplate capacity less than 1 MW is generated by dGen™
- County-level allocations of forecast for MW-scale systems (PV only) are developed based on:
 - Historical share of MW-scale system in each county
 - Land availability (using county population density as proxy)
 - Land value (using county median income as proxy)
 - Remaining area hosting capacity (estimated using substation electricity demand data)
- County-level forecast results are included in the [Appendix IV](#)

CLASSIFICATION OF DER FORECAST

Results



Classification Needed to Determine BTM DER

- Ultimately, the ISO needs to determine the amount of DER that is not expected to participate in wholesale markets, and instead reduces load
 - This is the amount of BTM DER that is reflected in the long-term load forecast
- To properly account for existing and future DER in planning studies and avoid double counting, ISO classifies all DER PV and BESS included in the 2026 DER forecast as the following:
 - All DER PV are classified into three distinct categories related to its assumed market participation/non-participation
 - All DER BESS are classified as BTM
- Accounting for these market distinctions is performed for both installed nameplate capacity and estimates of hourly energy production (historical and forecast), and is important for the ISO's use of the DER forecast in planning studies
- Details of classification methods are included in [Appendix VI](#)

Final 2026 Regional PV Forecast

Cumulative Nameplate by Category, MW_{ac}

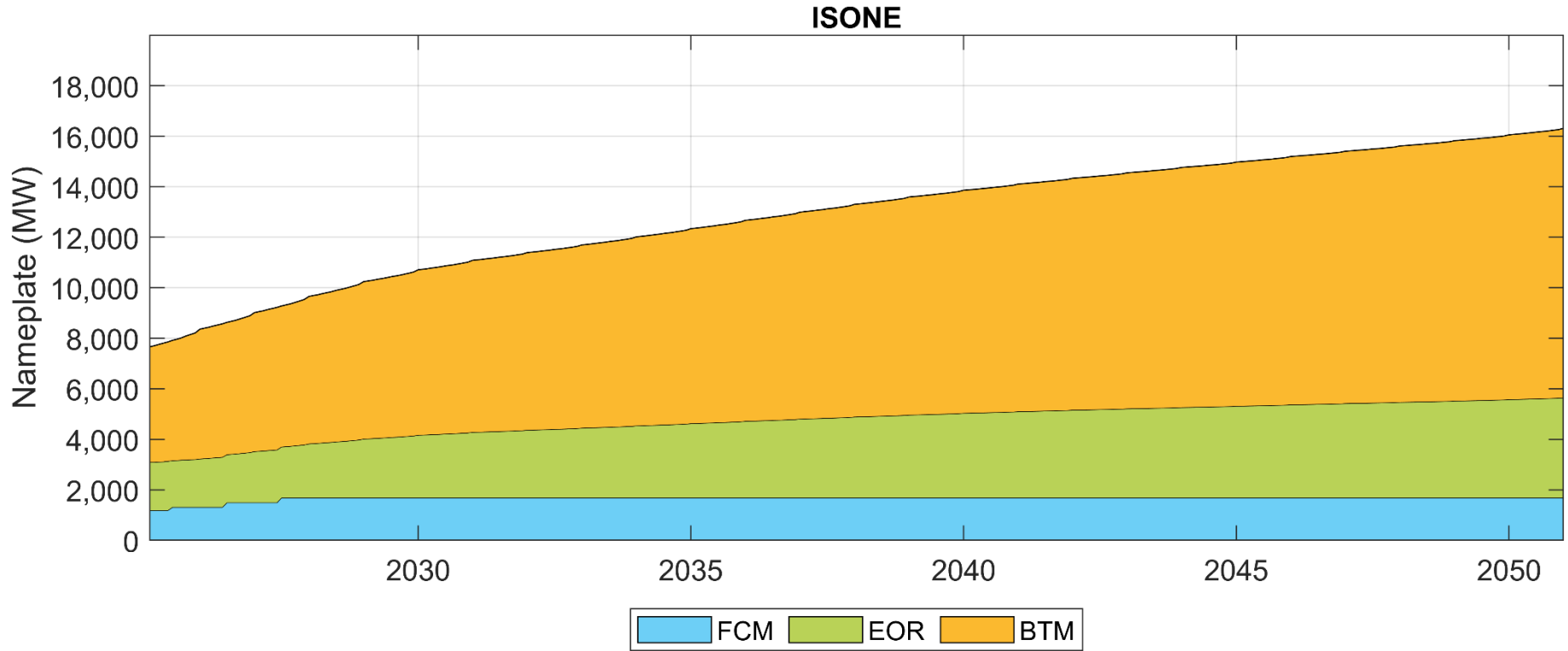

Final 2026 State PV Forecast

Cumulative Nameplate by Category, MW_{ac}

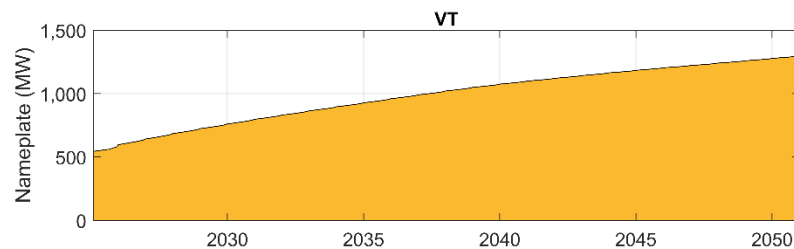
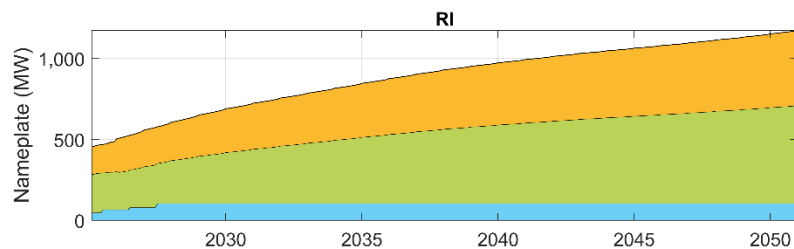
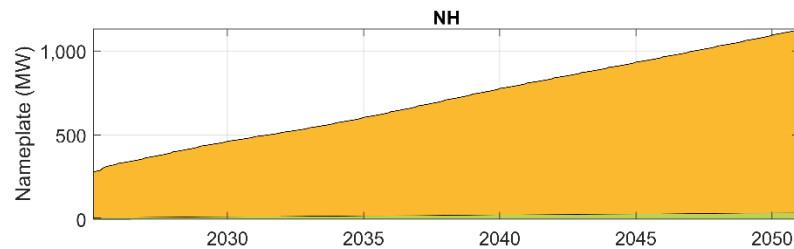
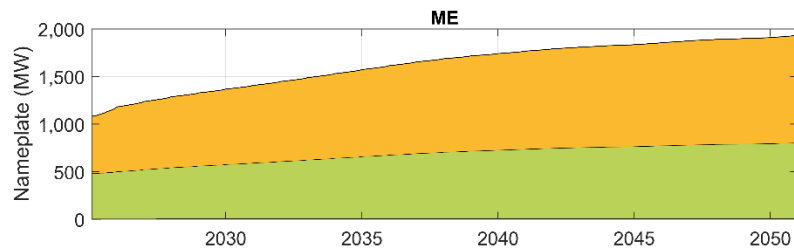
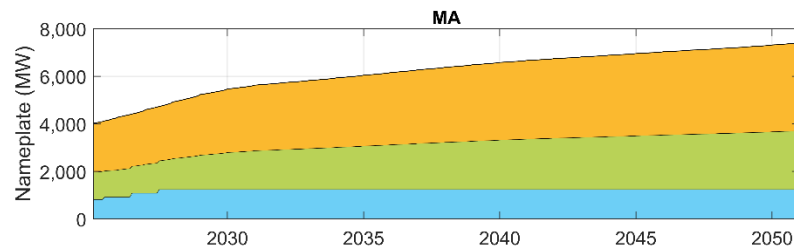
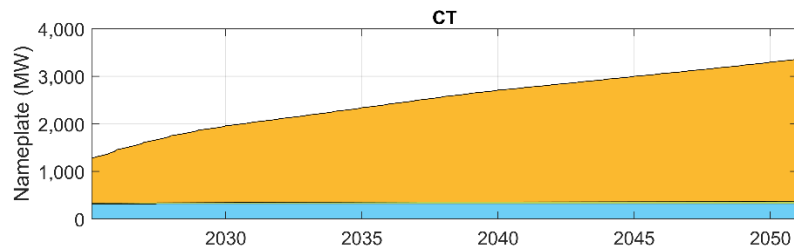

FCM EOR BTM

ISO-NE PUBLIC

2026 BTM DER ENERGY FORECAST



BTM DER Energy Forecast

- Monthly energy forecasts are the averages of the 70 monthly energy values of simulations performed for each forecast year
 - For example, January energy forecast is the average of all 70 January energy values withing the 70-year simulation period for a given forecast year
- Annual energy forecast is calculated as the sum of monthly energy forecasts for each forecast year
- Details of the development of the BTM DER energy forecast are included in [Appendix VII](#)

Final 2026 BTM PV Energy Forecast – 10 Year Horizon

BTM PV, GWh

States										
	2026	2027	2028	2029	2030	2031	2032	2033	2034	2035
CT	1,616	1,813	1,983	2,123	2,231	2,328	2,420	2,514	2,610	2,706
MA	3,015	3,119	3,280	3,473	3,610	3,696	3,752	3,809	3,871	3,937
ME	927	966	999	1,027	1,054	1,081	1,108	1,137	1,165	1,194
NH	433	474	516	555	590	621	651	684	720	758
RI	304	323	342	365	385	402	418	434	449	465
VT	761	814	863	907	950	992	1,029	1,067	1,102	1,137
Regional - Annual Energy (GWh)	7,056	7,509	7,983	8,451	8,820	9,119	9,379	9,644	9,919	10,197

Notes:

- (1) Forecast values include energy behind-the-meter PV resources only
- (2) Monthly in-service dates of PV assumed based on historical development
- (3) Values include the effects of an assumed 0.5%/year PV panel degradation rate
- (4) All values are grossed up by 6% to reflect avoided transmission and distribution losses

Final 2026 BTM PV Energy Forecast – New England

BTM PV, GWh

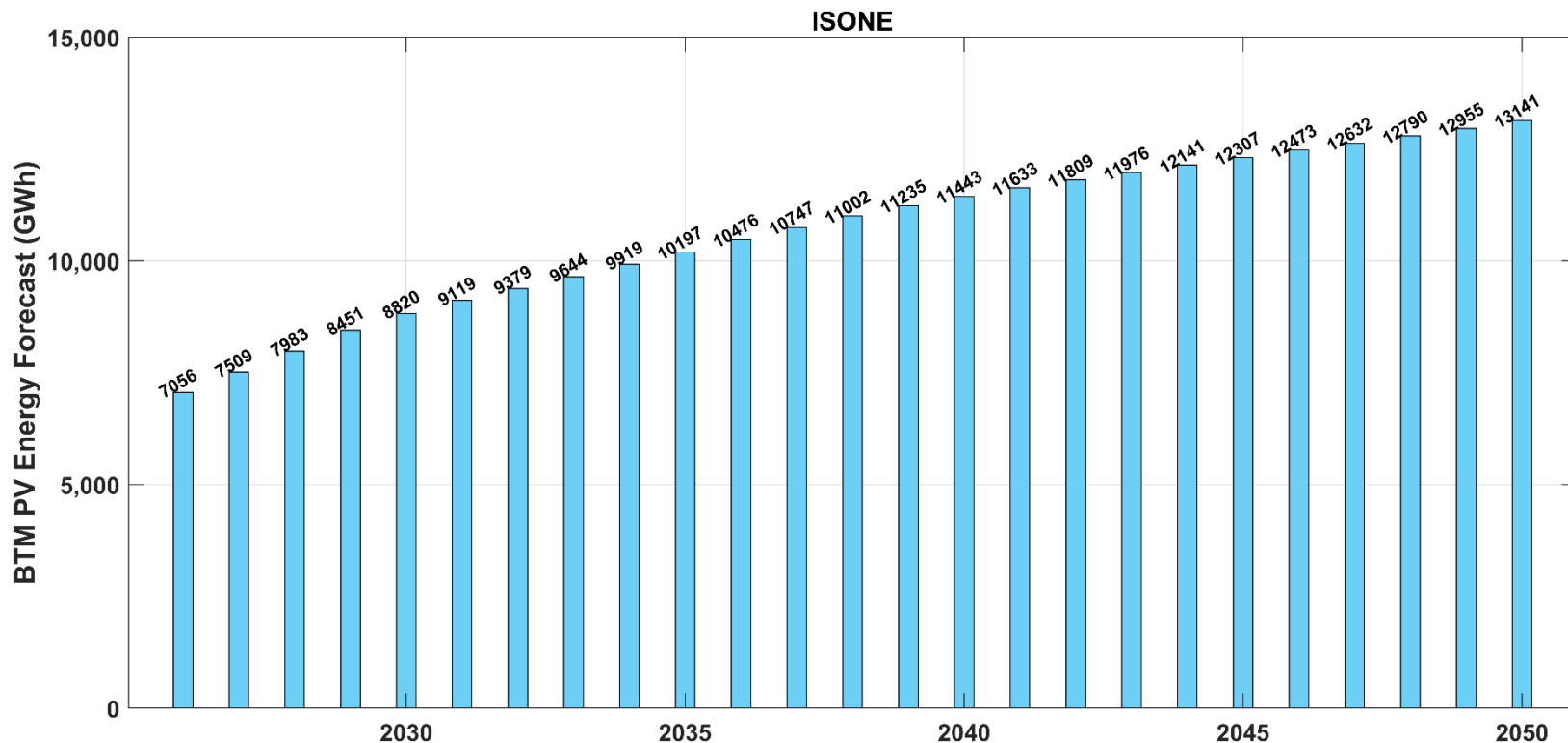

Final 2026 BTM PV Energy Forecast – State Level

BTM PV, GWh

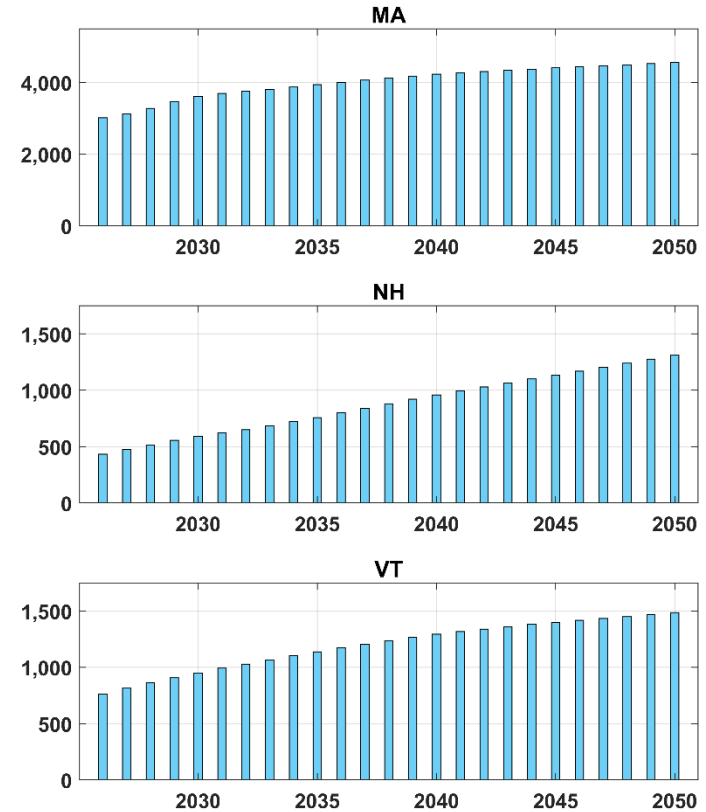
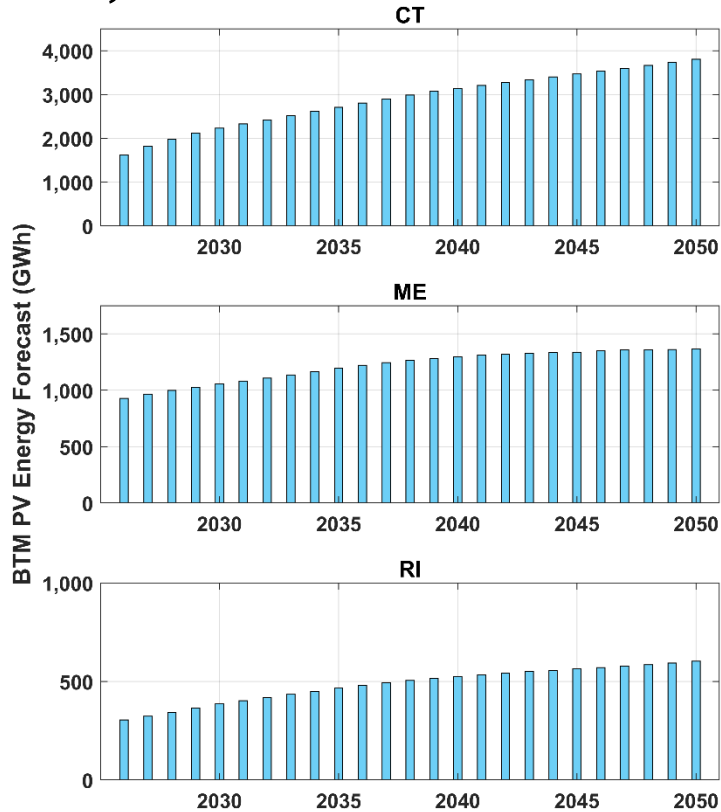

2026 BTM DER PEAK DEMAND REDUCTIONS



Use of BTM DER Forecasts in CELT Net Load Forecast

- The 2026 CELT net load forecast will reflect the impacts of the BTM DER portion of the DER forecast
 - Includes both BTM PV and BTM BESS
- Summer and winter seasonal peak impacts associated with BTM DER over the forecast horizon are calculated using the waterfall approach described and illustrated on the next slide

Demand Impacts of Load Components

Waterfall Approach

- The hourly forecast results in a dynamic interplay of modeled load components
 - Peak hour shifts due to the growth of one component affect the peak attribution of other components
 - Attribution of peak load values to components is path dependent

- A waterfall approach to the attribution of peak load contributions is used to standardize this forecast accounting

- Waterfall method steps (refer to plot):

- Base = Base peak load value
19,339 MW
- EV = (Base+EV) – Base
21,886 – 19,339 = 2,547 MW
- HP = (Base+EV+HP) – (Base+EV)
32,315 – 21,886 = 10,429 MW
- LargeLd = (Base+EV+HP+LargeLd) – (Base+EV+HP)
32,436 – 32,315 = 121 MW
- BTM PV = Gross – (Gross-BTM PV)
32,436 – 31,687 = 749 MW
- BTM BESS = (Gross-BTM PV) – Net
31,687 – 31,556 = 121 MW

Example Winter Peak Day, 2038

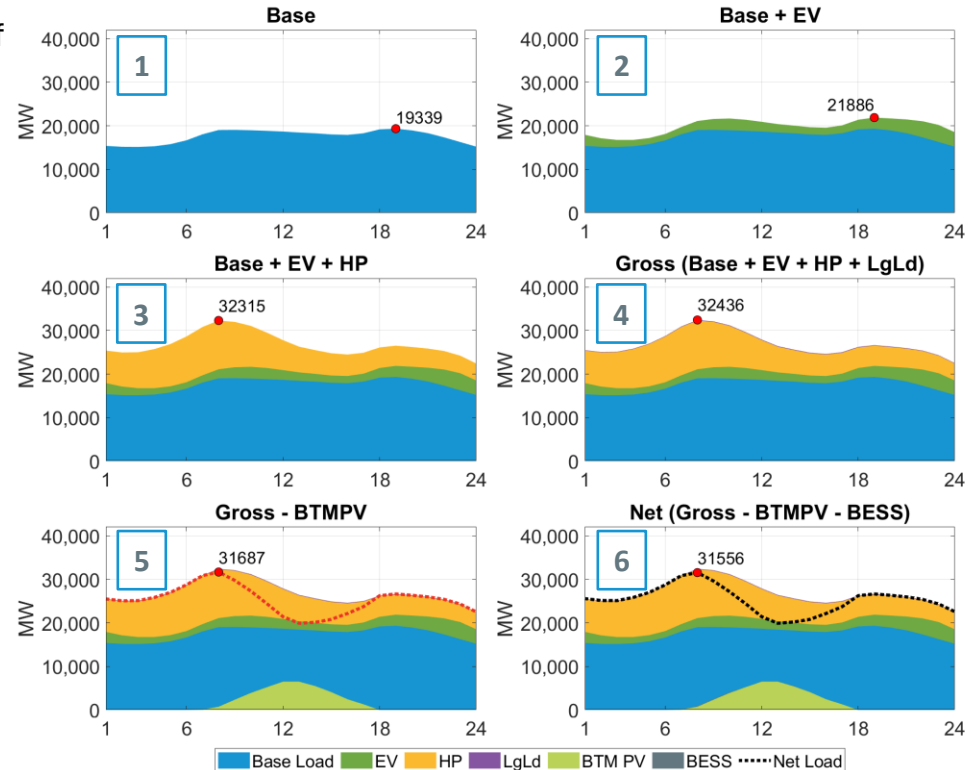

Final 2026 BTM PV Forecast – Summer

Coincident “50-50” Summer Peak Load Reductions

Category	States	Cumulative Total MW - "50-50" Summer Seasonal Peak Load Reduction									
		2026	2027	2028	2029	2030	2031	2032	2033	2034	2035
Behind-the-Meter PV	CT	401	438	461	480	496	508	517	523	526	524
	NEMA	191	198	204	209	213	214	213	210	207	203
	SEMA	284	284	293	304	312	314	313	310	306	300
	WCMA	287	287	292	298	302	303	301	296	290	284
	ME	217	221	220	218	218	219	220	219	218	217
	NH	110	117	123	128	132	136	140	143	146	149
	RI	75	77	79	82	85	88	89	90	90	90
	VT	194	202	207	209	209	213	216	219	220	220
	ISONE	1,759	1,824	1,880	1,928	1,966	1,994	2,009	2,011	2,003	1,986

Notes:

- (1) Forecast values include energy behind-the-meter PV resources only
- (2) Monthly in-service dates of PV assumed based on historical development
- (3) Values include the effects of an assumed 0.5%/year PV panel degradation rate
- (4) All values are grossed up by 8% to reflect avoided transmission and distribution losses

Final 2026 BTM PV Forecast – Winter

Coincident “50-50” Winter Peak Load Reductions

Category	States	Cumulative Total MW - "50-50" Winter Seasonal Peak Load Reduction									
		2026	2027	2028	2029	2030	2031	2032	2033	2034	2035
Behind-the-Meter PV	CT	0	0	0	0	1	15	32	51	71	92
	NEMA	0	0	0	0	0	5	11	18	25	32
	SEMA	0	0	0	0	1	8	17	27	37	48
	WCMA	0	0	0	0	1	8	16	26	35	45
	ME	0	0	0	0	0	5	11	18	25	33
	NH	0	0	0	0	0	3	7	12	16	22
	RI	0	0	0	0	0	3	6	10	13	17
	VT	0	0	0	0	0	5	10	15	21	27
	ISONE	0	0	0	0	4	53	110	176	243	316

Notes:

- (1) Forecast values include energy behind-the-meter PV resources only
- (2) Monthly in-service dates of PV assumed based on historical development
- (3) Values include the effects of an assumed 0.5%/year PV panel degradation rate
- (4) All values are grossed up by 8% to reflect avoided transmission and distribution losses

Final 2026 BTM BESS Forecast – Summer

Coincident “50-50” Summer Peak Load Reductions

Category	States	Cumulative Total MW - "50-50" Summer Seasonal Peak Load Reduction									
		2026	2027	2028	2029	2030	2031	2032	2033	2034	2035
Behind-the-Meter BESS	CT	2.1	6.5	11.1	14.9	17.2	18.0	18.0	18.0	18.0	18.1
	NEMA	2.1	7.3	13.4	18.8	22.4	23.6	23.8	24.3	24.8	25.4
	SEMA	3.2	11.1	21.7	32.1	39.0	41.4	41.4	41.4	41.4	41.4
	WCMA	1.7	6.0	11.9	18.0	21.9	23.3	23.3	23.3	23.4	23.6
	ME	0.5	1.5	2.5	3.4	4.0	4.2	4.3	4.4	4.5	4.6
	NH	0.2	0.8	1.4	2.0	2.3	2.4	2.4	2.5	2.5	2.6
	RI	0.1	0.4	0.8	1.3	1.7	1.9	1.9	1.9	1.9	1.9
	VT	0.8	2.1	3.2	3.8	4.3	4.7	5.1	5.4	5.7	6.0
	ISONE	10.6	35.8	66.1	94.4	112.8	119.4	120.2	121.1	122.2	123.6

Notes:

(1) All values are grossed up by 8% to reflect avoided transmission and distribution losses

Final 2026 BTM BESS Forecast – Winter

Coincident “50-50” Winter Peak Load Reductions

Category	States	Cumulative Total MW - "50-50" Winter Seasonal Peak Load Reduction									
		2026	2027	2028	2029	2030	2031	2032	2033	2034	2035
Behind-the-Meter BESS	CT	4.9	9.2	12.9	14.5	12.9	8.8	4.1	0.9	0.0	0.0
	NEMA	5.1	11.0	16.0	18.7	16.9	11.5	5.4	1.2	0.0	0.0
	SEMA	7.7	16.9	26.8	32.5	29.7	20.2	9.4	2.0	0.0	0.0
	WCMA	4.2	9.2	14.9	18.3	16.7	11.4	5.3	1.1	0.0	0.0
	ME	1.1	2.1	3.0	3.4	3.0	2.1	1.0	0.2	0.0	0.0
	NH	0.6	1.2	1.7	1.9	1.7	1.2	0.6	0.1	0.0	0.0
	RI	0.3	0.6	1.0	1.4	1.4	0.9	0.4	0.1	0.0	0.0
	VT	1.8	2.8	3.4	3.6	3.3	2.4	1.2	0.3	0.0	0.0
	ISONE	25.6	53.0	79.7	94.4	85.6	58.5	27.3	6.0	0.0	0.0

Notes:

(1) All values are grossed up by 8% to reflect avoided transmission and distribution losses

APPENDIX I

2025 DER Interconnection Data Update



2025 DER PV Nameplate Capacity Growth

- A comparison of forecast PV growth (CELT 2025) and growth reported by DER data providers through December 2025 is tabulated
 - Regionally, through December 2025, the CELT 2025 forecast is lower than the reported growth by 52 MW (~7.6% lower)
- These data inform the final DER PV nameplate forecast

State	A 2025 Forecast Growth, MW (CELT 2025 - Through December 2025)	B 2025 Reported Growth, MW (Through December 2025)	C Forecast Error (Through December 2025) [A-B]
CT	180	194	-14
MA	294	283	11
ME	72	104	-32
NH	36	53	-17
RI	67	43	24
VT	33	56	-23
ISO-NE	681	733	-52

December 2025 Cumulative DER PV Totals

State-by-State

The table below reflects statewide aggregated PV data provided to ISO New England by regional Distribution Owners and/or Transmission Owners. The values represent installed nameplate as of 12/31/2025

State	Installed Capacity (MW _{AC})	No. of Installations
Massachusetts	4,286	228,529
Connecticut	1,458	115,882
Vermont	597	23,707
New Hampshire	333	27,461
Rhode Island	504	28,312
Maine	1,181	20,267
New England	8,359	444,158

December 2025 Cumulative DER PV Totals (1 of 2)

Summary of PP12 DER PV Data

State	Utility	Installed Capacity (MW _{AC})	No. of Installations
CT	Connecticut Light & Power	1,188	93,744
	United Illuminating	228	21,166
	Municipal Electric Companies	42	972
	Total	1,458	115,882
MA	National Grid	2,207	122,939
	NSTAR	1,380	74,779
	Wester Massachusetts Electric Co.	447	22,322
	Municipal Electric Companies	252	8,489
	Total	4,286	228,529
ME	Central Maine Power	949	17,541
	Versant*	232	2,726
	Total	1,181	20,267

* Does not include installations in Maine Public District

December 2025 Cumulative DER PV Totals (2 of 2)

Summary of PP12 DER PV Data

State	Utility	Installed Capacity (MW _{AC})	No. of Installations
NH	Liberty Utilities	25	1,982
	New Hampshire Electric Co-op	26	2,367
	Public Service of New Hampshire	244	20,263
	Unitil (UES)	38	2,849
	Total	333	27,461
RI	Rhode Island Energy	504	28,304
	Municipal Electric Companies	<1	8
	Total	504	28,312
VT	Burlington Electric Department	10	460
	Green Mountain Power	494	18,254
	Vermont Electric Co-op	48	2,845
	Washington Electric Co-op	9	1,018
	Municipal Electric Companies	36	1,130
	Total	597	23,707
New England		8,359	444,158

December 2025 Cumulative DER PV Totals

By Data Provider

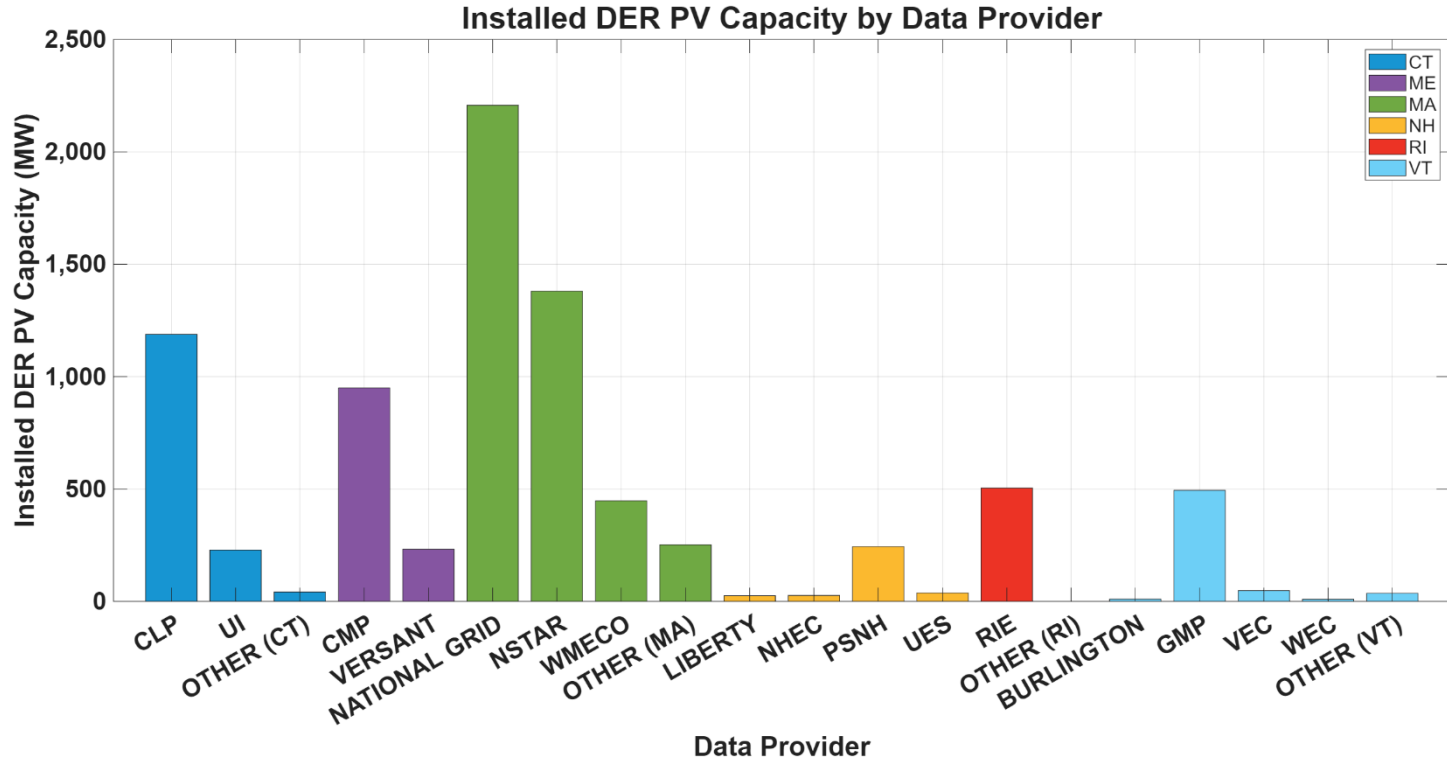

DER BESS Interconnection Data

- Full characterization of existing DER storage is not possible due to incomplete storage-related data
 - Incomplete storage parameters include: installed nameplate capacity, installed energy capacity, storage injection capability, facility import limit, facility export limit
 - Data completeness and quality are expected to improve over time
- PP12 data suggest that a total of 563 MW of DER storage was interconnected at the end of December 2025
 - 407 MW of hybrid PV/Storage and 156 MW of storage only facilities
- The results of the December 2025 PP12 DER storage data are tabulated on the following slide

December 2025 Cumulative DER BESS Total

Large vs Small Installations, Hybrid PV/Storage + Storage Only

State	Nameplate Capacity (MW)	MW-scale Capacity (MW)		<1 MW-scale Capacity (MW)	
		Standalone	Hybrid PV/Storage	Standalone	Hybrid PV/Storage
CT	21.4	0	7.7	5.5	8.3
ME	40.7	5.0	32.2	0.5	3.0
MA	386.9	63.9	256.5	13.4	53.2
NH	3.7	0	0	0.5	3.2
RI	18.4	3.0	0	0.2	15.2
VT	91.9	41.1	0	22.7	28.2
ISO-NE	563.1	113.0	296.4	42.7	111.0

- PP12 reporting indicates that hybrid PV/BESS with nameplate capacity less than 1 MW accounts for 20% of the total installed BESS
- Incomplete BESS data remains a challenge to the ISO's BESS forecasting efforts

APPENDIX II

Forecast Assumptions



Massachusetts Forecast Assumptions

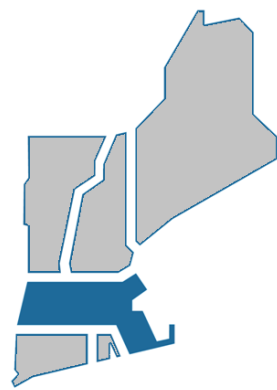

- Policy information is contained in the MA Department of Public Utilities (MA DPU) [presentation](#) to the DGFWDG on December 8, 2025
- PP12 reporting included a total of 1,878.6 MW_{AC} of MW-scale systems installed through 12/31/2025 with less observable growth from large systems since 2022.
- PP12 reporting shows a 3-year average growth rate for MW-scale systems of 76.7 MW_{AC} with 60.5 MW_{AC} installed in 2025
- The downward growth trend is expected to continue

Connecticut Forecast Assumptions

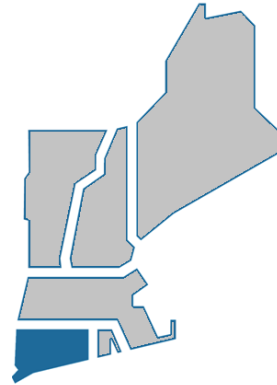

- Policy information is contained in the CT Department of Energy & Environmental Protection (CT DEEP) [presentation](#) to the DGFVG on December 8, 2025
- A total of 453.4 MW_{AC} are operational under the existing Low- & Zero-Emission Renewable Energy Credits (LREC/ZREC) program, and 40.8 MW are expected to come online.
 - Based on the historical share of large systems, assume 2.4 MW_{AC} to be from large systems
- 16 MW_{AC} are in service under the Shared Clean Energy Facility (SCEF) program, with another 189 MW selected
 - Assume all of the selected MW are large systems, and that another 50 MW_{AC} are expected to be installed under the program's 2026 procurement
 - In addition, Public Act 24-31 extended the SCEF program from 6 years to 8 years
- An estimate of 107 MW_{AC} of MW-scale systems were selected under Non-Residential Energy Solution. An addition of 115 MW_{AC} are expected to be installed throughout the remaining period of the program
- PP12 reporting shows a 3-year average growth rate for MW-scale systems of 25.2 MW_{AC} with 36.2 MW_{AC} installed in 2025
- With a significant backlog of projects being operational, the MW-scale growth in CT is expected to increase while ITC remains in effect

Rhode Island Forecast Assumptions

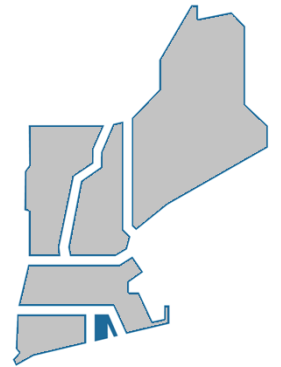

- Policy information is contained in the RI Office of Energy Resources (RI OER) [presentation](#) to the DGFWG on December 8, 2025
- 236.2 MW_{AC} of large system were installed by the end of December 2025. An addition of 75 MW_{AC} of large systems are planned from 2024-2026 according to the Renewable Energy Growth (REG) Program Drafted Megawatt Allocation Plan
- Historical data on Renewable Energy Fund (REF) does not include any large systems
- PP12 reporting shows a 3-year average growth rate for MW-scale systems of 20.5 MW_{AC} with 13.6 MW_{AC} installed in 2025
- The megawatt-scale growth in RI is expected to decrease throughout the forecast horizon

Vermont Forecast Assumptions



- Policy information is contained in the VT Department of Public Service (VT PSD) [presentation](#) to the DGFVG on December 8, 2025
- 108 MW_{AC} were installed under the Standard Offer program. An addition of 10 MW_{AC} are anticipated, all of which are large systems
- DG carve-out of the Renewable Energy Standard (RES) and its supporting policies (Standard Offer Program, net metering) drive distributed PV growth to match a growing share of VT's annual load energy, with the following assumptions:
 - All forward-looking renewable energy certificates (RECs) from Standard Offer and net metered projects will be sold to utilities and count towards RES DG carve-out
- PP12 reporting shows a 3-year average growth rate for MW-scale systems of 21.3 MW_{AC} with 39.6 MW_{AC} installed in 2025
- The forecast assumed a near-term increase in the adoption due to the increase in DG RES obligations for utilities in VT. The forecast considered recent DG RES policy changes in VT by increasing the assumed growth of MW-scale systems until 2035

New Hampshire Forecast Assumptions

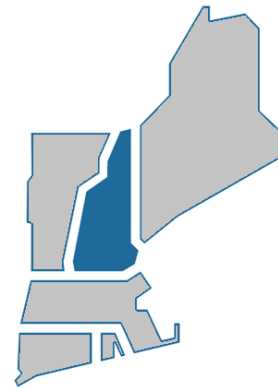

- Policy-based (large system):
 - Policy information is contained in the NH Department of Energy (NH DOE) [presentation](#) to the DGFWG on December 8, 2025
 - Per NH’s net metering tariff, Municipal Hosts are permitted to install projects up to 5 MW
 - PP12 reporting suggests that there is an addition of 34.5 MW_{AC} of MW-scale systems in NH through December 2025 with 17.5 MW_{AC} installed in 2025. Therefore, the MW-scale forecast for NH is adjusted slightly upward

Maine Forecast Assumptions



- Policy information is contained in the ME Governor’s Energy Office (ME GEO) [presentation](#) to the DGFWDG on December 8, 2025
- PP12 reporting indicates a total of 894.9 MW_{AC} of MW-scale systems installed through 12/31/2025, with 23.8 MW_{AC} installed in 2025
- Annual state MW forecast inputs tabulated below result from the following state programs:
 - Net Energy Billing (NEB), 2-5 MW projects
 - Assume 750 MW total, all of which came online through 2024
 - NEB Successor, 2-5 MW projects
 - Assume 560 MW total program goal, minus 5% of program capacity assumed to be installed in Maine Public District (i.e., outside of ISO New England) and approximately 130 MW that came online through 2024
 - NEB, < 2MW projects, with an assumed annual growth of 5 MW
- The downward growth trend of MW-scale projects in ME is expected to continue

Megawatt-scale PV Forecast Inputs

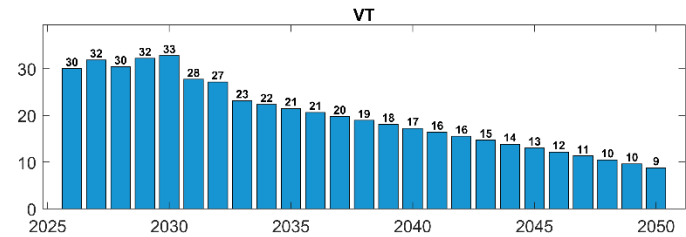
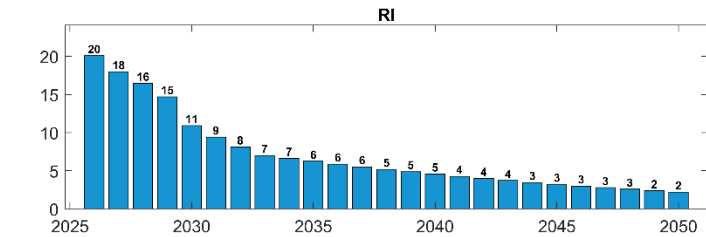
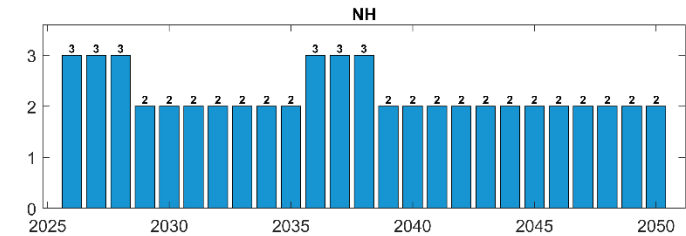
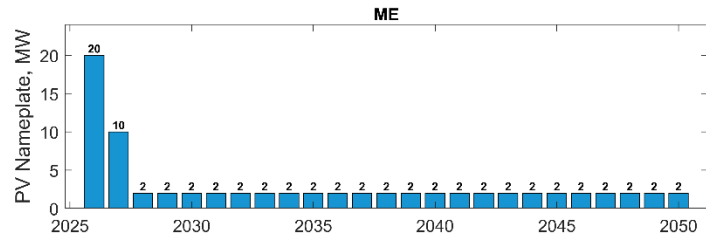
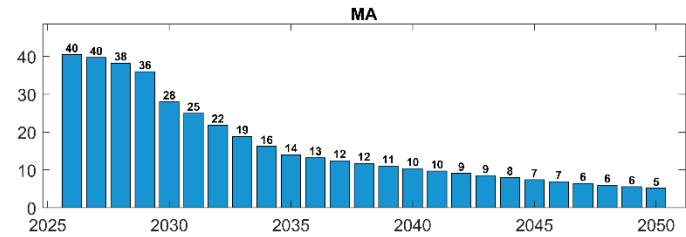
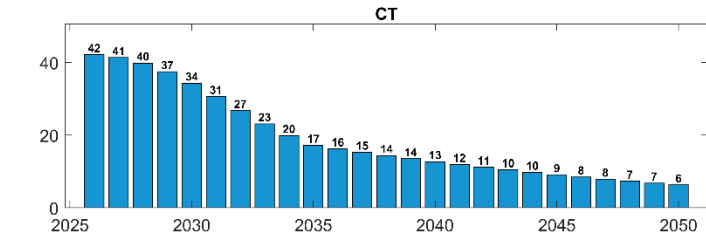

APPENDIX III

Forecast Inputs and Discount Factors



2026 DER PV Forecast Inputs – 10-Year Horizon

Nameplate Capacity, PV Systems < 1 MW

States	Annual Total MW (AC nameplate rating)											Totals
	Thru 2025	2026	2027	2028	2029	2030	2031	2032	2033	2034	2035	
CT	1,250	126	114	95	68	61	59	63	72	76	82	2,065
MA	2,408	297	323	321	244	170	102	109	124	132	145	4,376
ME	286	41	46	45	44	44	46	47	48	48	48	743
NH	298	33	36	36	33	30	29	30	34	36	39	633
RI	268	38	36	34	31	29	28	29	30	30	30	584
VT	383	19	16	14	12	12	13	14	17	18	19	537
ISONE	4,894	553	572	545	433	347	277	292	324	340	363	8,939

Notes:

- (1) The above values **are not forecast values**, but rather pre-discounted inputs to the forecast (see [discount factors slides](#) for details)
- (2) The above values do not reflect end-of-life accounting (see [end-of-life accounting slides](#) for details)
- (3) All values include FCM Resources, non-FCM Settlement Only Generators and Generators (per OP-14), and load reducing PV resources
- (4) All values represent end-of-year installed capacities

2026 DER PV Forecast Inputs – 10-Year Horizon

Nameplate Capacity, PV Systems 1-5 MW

States	Annual Total MW (AC nameplate rating)											Totals
	Thru 2025	2026	2027	2028	2029	2030	2031	2032	2033	2034	2035	
CT	208	42	41	40	37	34	31	27	23	20	17	521
MA	1,879	40	40	38	36	28	25	22	19	16	14	2,157
ME	895	20	10	2	2	2	2	2	2	2	2	941
NH	35	3	3	3	2	2	2	2	2	2	2	58
RI	236	20	18	16	15	11	9	8	7	7	6	354
VT	215	30	32	30	32	33	28	27	23	22	21	494
ISONE	3,467	156	144	130	124	110	97	88	76	69	63	4,523

Notes:

- (1) The above values **are not forecast values**, but rather pre-discounted inputs to the forecast (see [discount factors slides](#) for details)
- (2) The above values do not reflect end-of-life accounting (see [end-of-life accounting slides](#) for details)
- (3) All values include FCM Resources, non-FCM Settlement Only Generators and Generators (per OP-14), and load reducing PV resources
- (4) All values represent end-of-year installed capacities

2026 DER PV Forecast Inputs – 10-Year Horizon

Pre-Discounted Nameplate Values, All PV Systems

States	Annual Total MW (AC nameplate rating)											Totals
	Thru 2025	2026	2027	2028	2029	2030	2031	2032	2033	2034	2035	
CT	1,458	168	155	134	106	96	89	90	95	96	99	2,586
MA	4,287	338	363	359	280	198	127	130	142	148	159	6,533
ME	1,181	61	56	47	46	46	48	49	50	50	50	1,684
NH	333	36	39	39	35	32	31	32	36	38	41	691
RI	504	58	54	51	46	40	38	37	37	37	36	938
VT	597	49	48	45	44	45	41	41	40	40	41	1,031
Pre-Discount Cumulative Total (MW)	8,361	9,069	9,785	10,460	11,017	11,474	11,847	12,227	12,627	13,036	13,463	13,463

Notes:

- (1) The above values **are not the forecast**, but rather pre-discounted inputs to the forecast (see [discount factors slides](#) for details)
- (2) The above values do not reflect end-of-life accounting (see [end-of-life accounting slides](#) for details)
- (3) All values include FCM Resources, non-FCM Settlement Only Generators and Generators (per OP-14), and load reducing PV resources
- (4) All values represent end-of-year installed capacities

2026 DER PV Forecast Inputs – Forecast Horizon

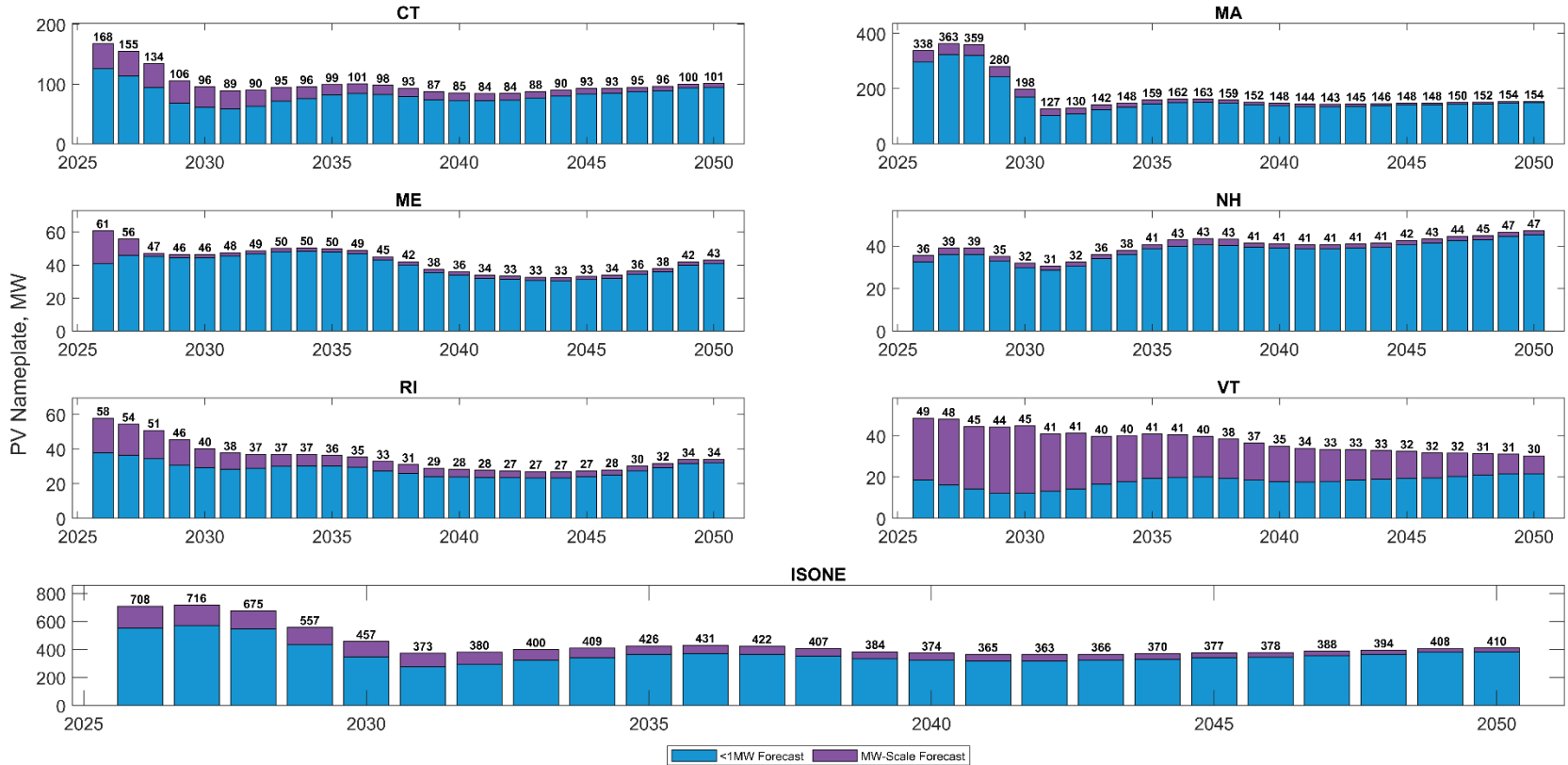

2026 DER BESS Forecast Inputs – 10-Year Horizon

Pre-Discounted Nameplate Values, All BESS Systems

States	Annual Total MW (AC nameplate rating)										Totals
	2026	2027	2028	2029	2030	2031	2032	2033	2034	2035	
CT	6	7	7	5	2	0	0	0	0	1	29
MA	22	32	39	31	15	0	1	1	1	1	143
ME	1	2	2	1	1	0	0	0	0	0	7
NH	1	1	1	1	0	0	0	0	0	0	4
RI	0	0	1	1	0	0	0	0	0	0	3
VT	2	2	1	1	1	1	1	1	0	0	10
ISONE	33	44	51	39	20	1	1	2	2	3	196

Notes:

- (1) The above values **are not the forecast**, but rather pre-discounted inputs to the forecast (see [discount factors slides](#) for details)
- (2) All values represent end-of-year installed capacities

2026 DER BESS Forecast Inputs – Forecast Horizon

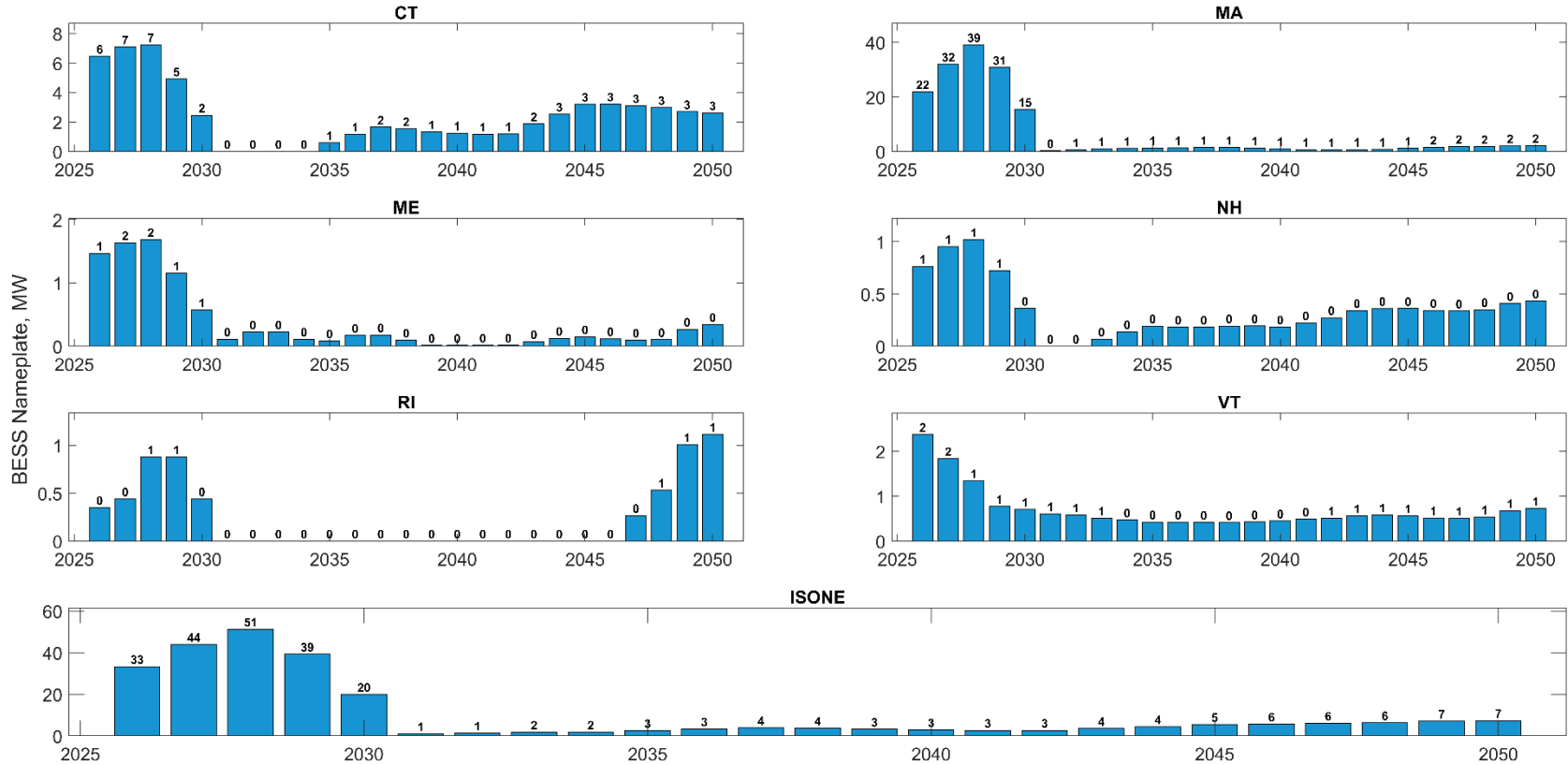

Discount Factors

- Discount factors are:
 - Developed and incorporated into the forecast to consider expected uncertainty
 - All discount factors are applied equally in all states
 - Applied to the forecast inputs to determine total nameplate capacity for each state and forecast year

Policy-Based

PV that results from state policy

Discounts for uncertainty associated with future market and grid conditions (maximum value of 15%)

Discount Factors Used

Forecast Year	Final 2025 Forecast	Final 2026 Forecast
2026	5%	7.5%
2027	7.5%	10%
2028	10%	12.5%
2029	12.5%	15%
2030	15%	15%
2031	15%	15%
2032	15%	15%
2033	15%	15%
2034	15%	15%
2035 - 2050	15%	15%

APPENDIX IV

2026 DER County-level Forecast

Final 2026 County PV Forecast – Connecticut



Legend: <1MW Forecast (blue), MW-Scale Forecast (purple)

Final 2026 County PV Forecast – Massachusetts

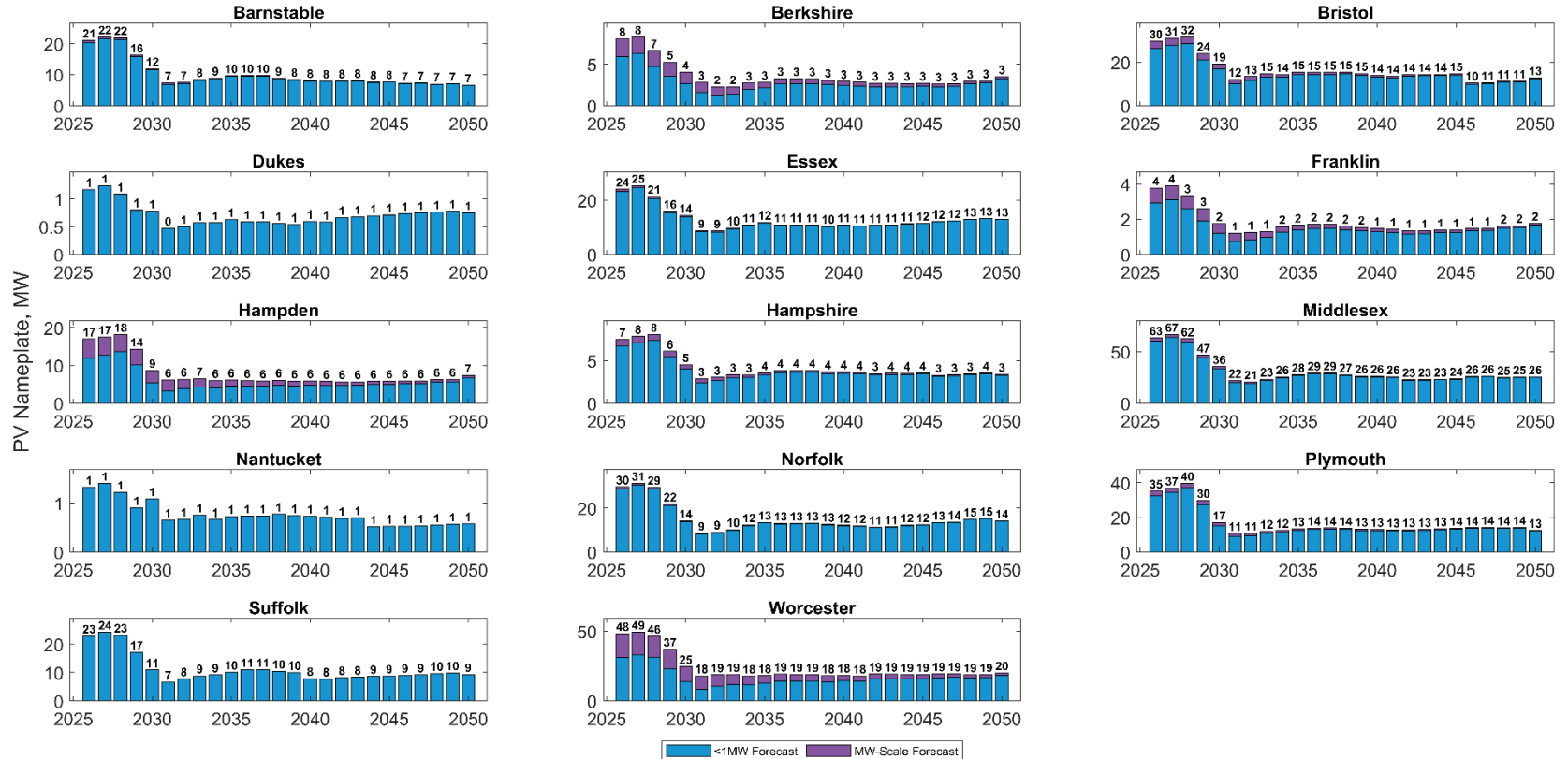

Final 2026 County PV Forecast – Maine

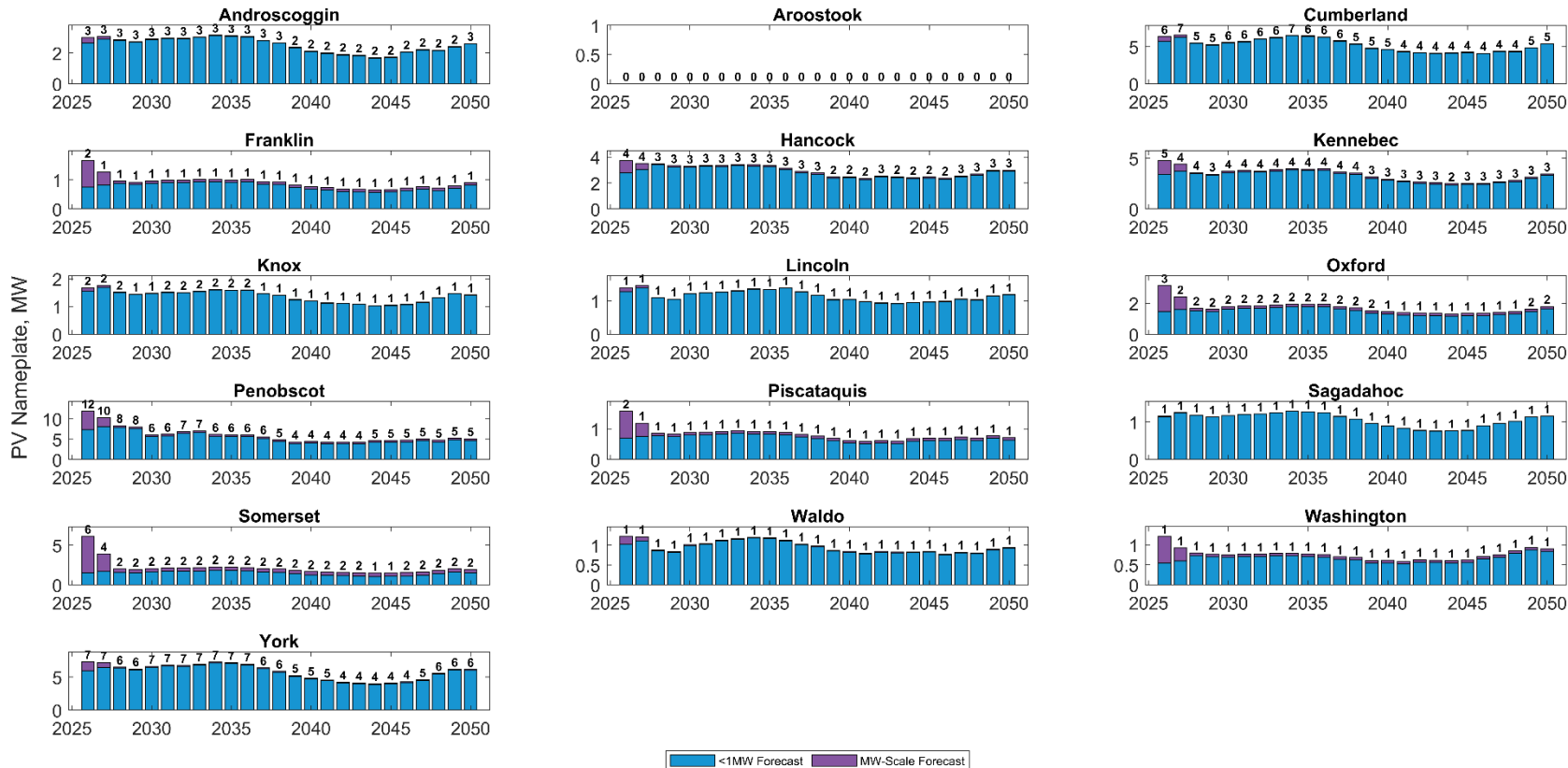

Legend: <1MW Forecast (blue), MW-Scale Forecast (purple)

Final 2026 County PV Forecast – New Hampshire



Legend: <1MW Forecast (blue), MW-Scale Forecast (purple)

Final 2026 County PV Forecast – Rhode Island

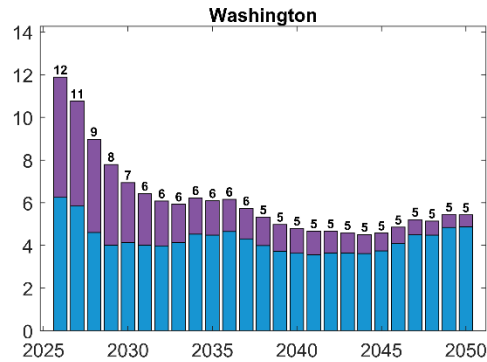
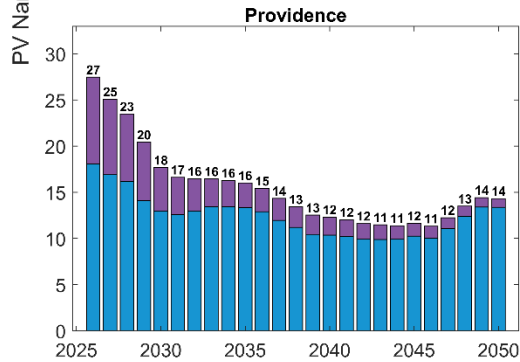
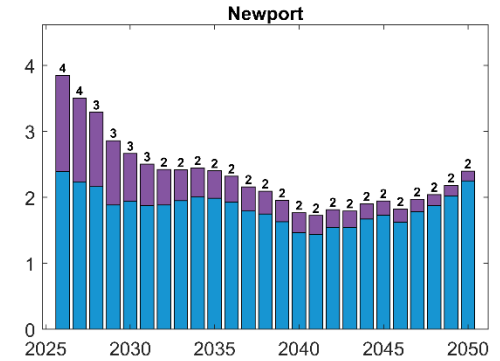
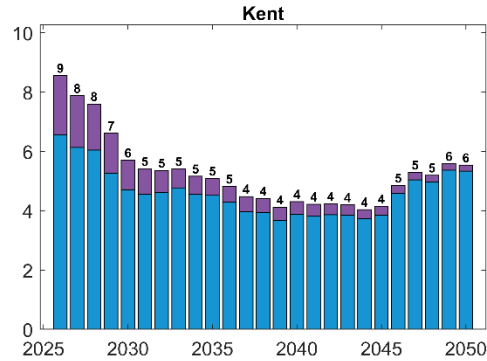
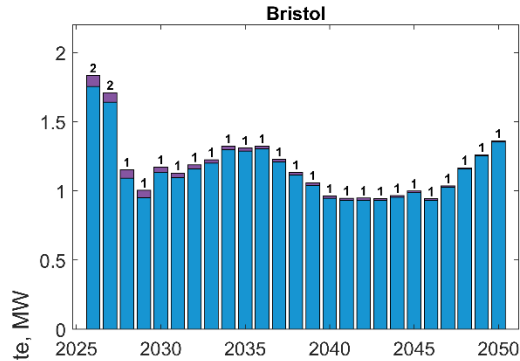

Legend: <1MW Forecast (Blue), MW-Scale Forecast (Purple)

Final 2026 County PV Forecast – Vermont



Legend: <1MW Forecast (blue), MW-Scale Forecast (purple)

Final 2026 County BESS Forecast – Connecticut

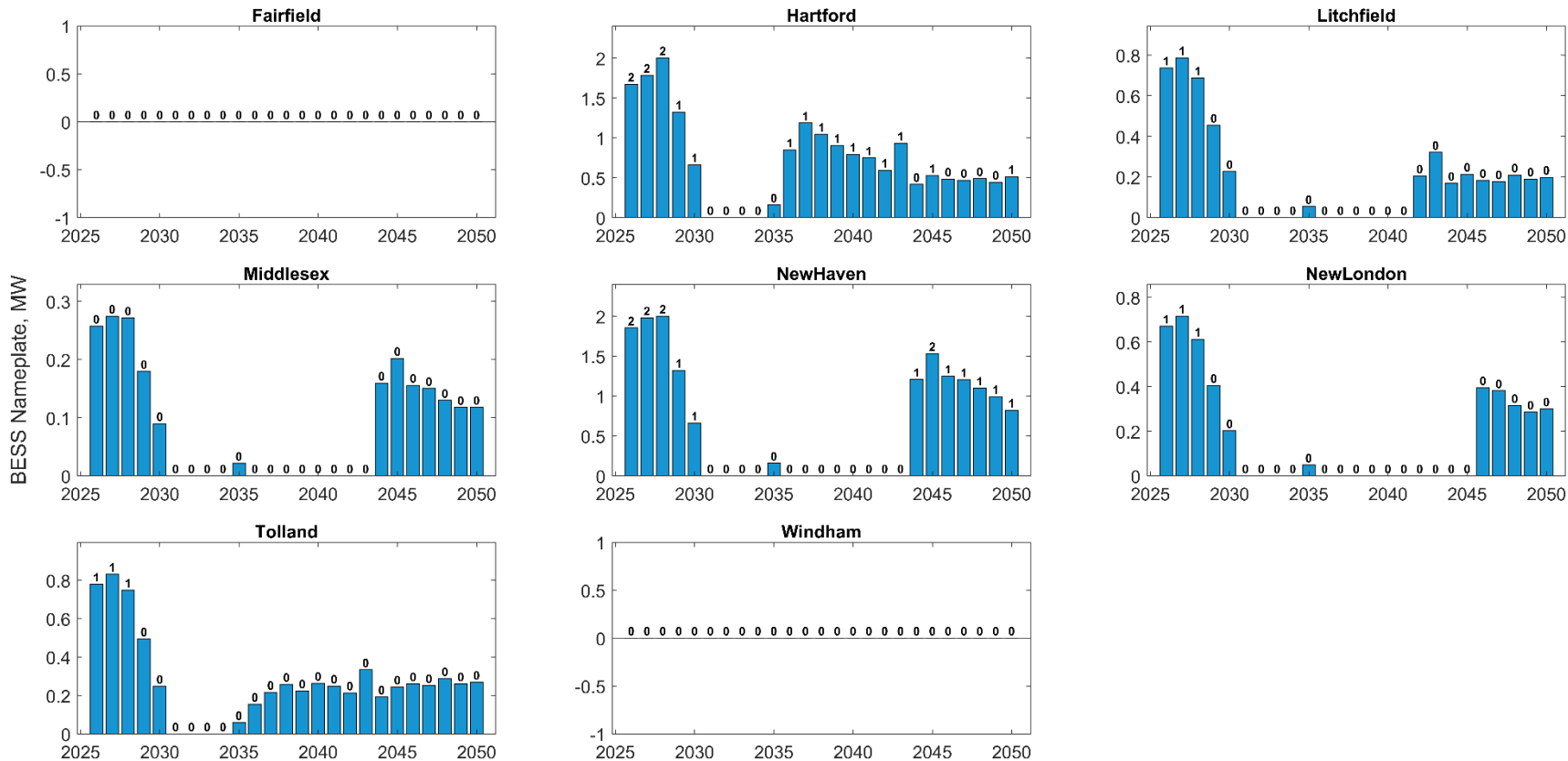

Final 2026 County BESS Forecast – Massachusetts

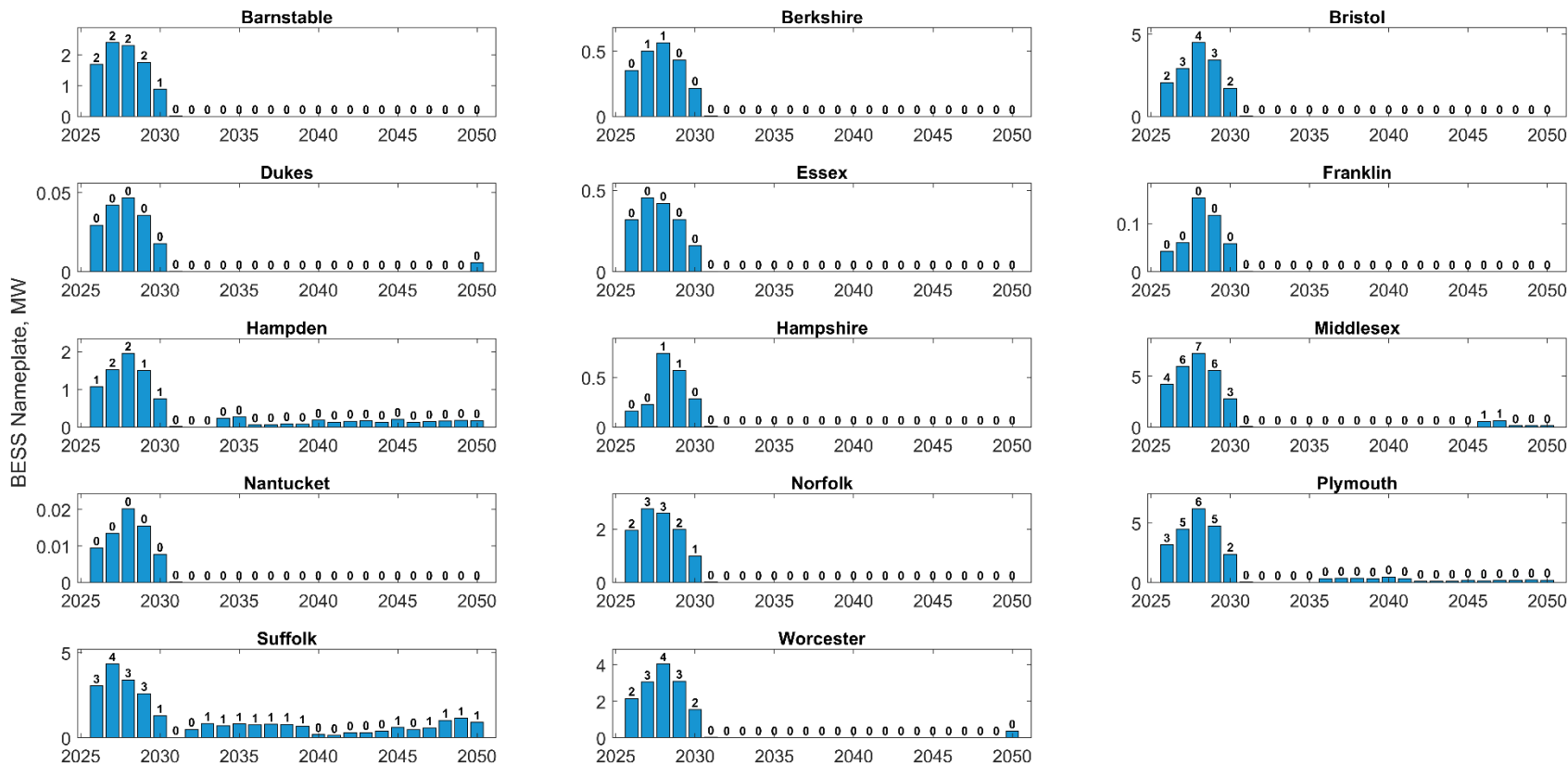

Final 2026 County BESS Forecast – Maine

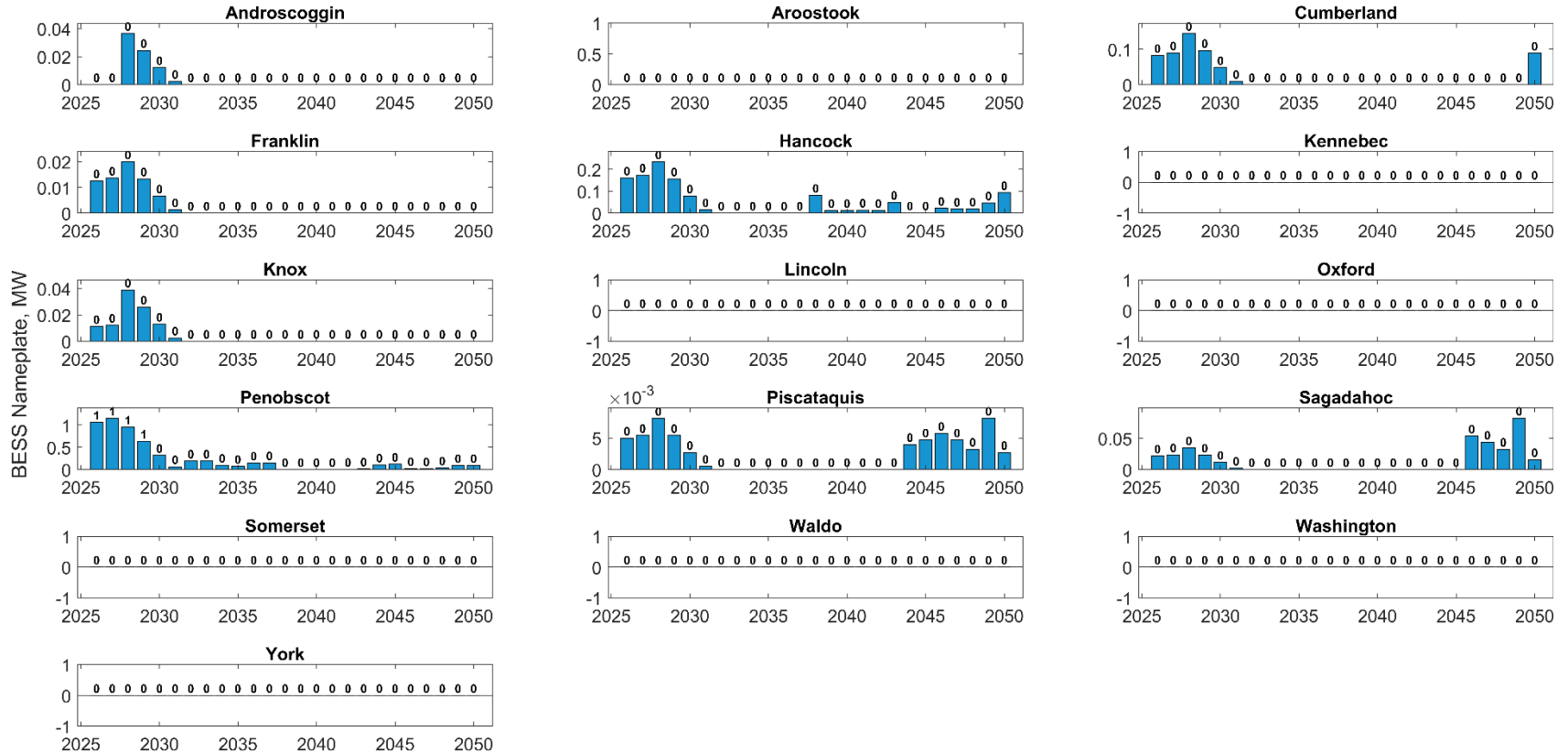

Final 2026 County BESS Forecast – New Hampshire

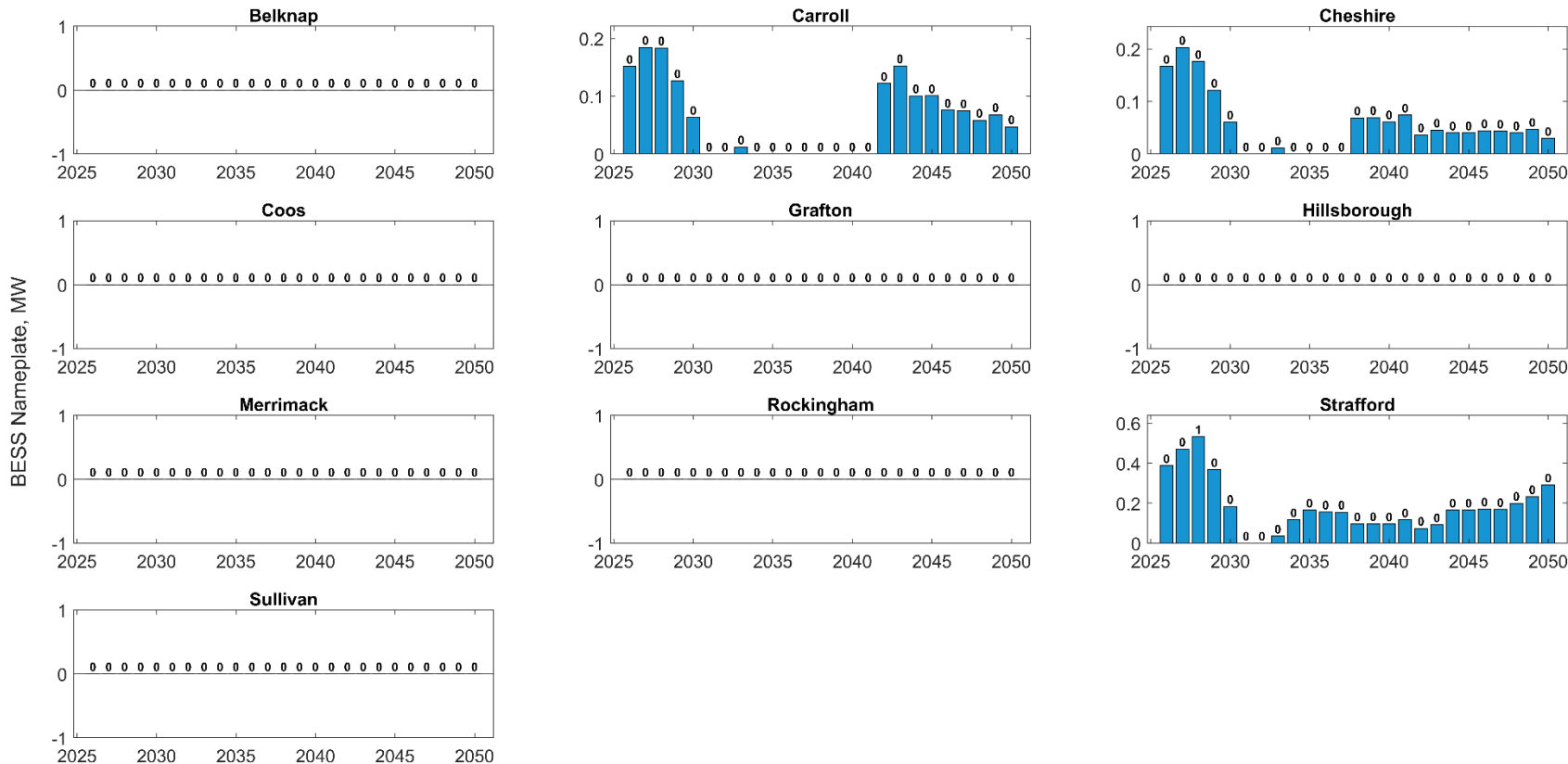

Final 2026 County BESS Forecast – Vermont

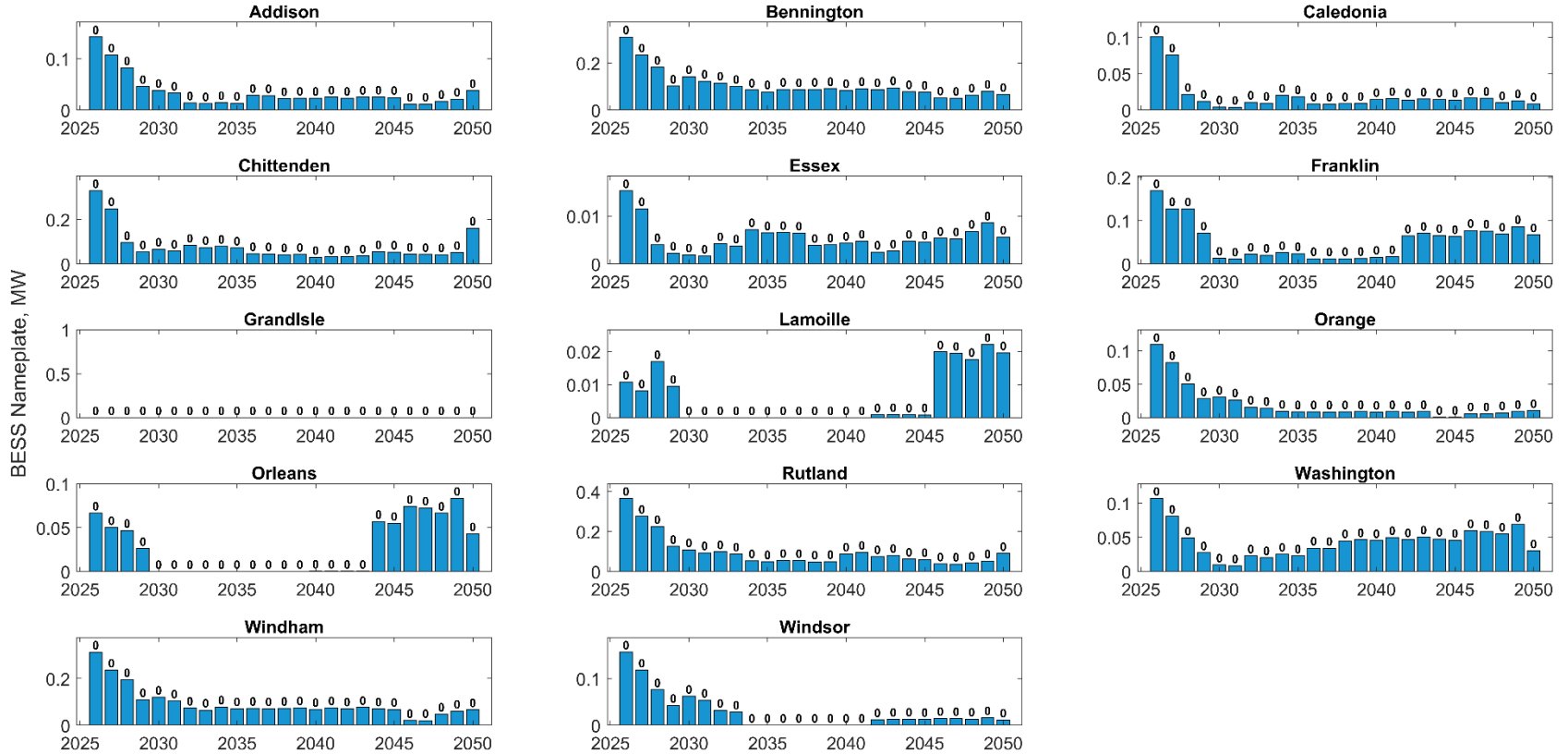

APPENDIX V

2026 DER Scenario Forecast

DER Scenario Forecast

- Scenario forecasts are developed under different assumptions that help quantify the range of potential future DER growth
- Final CELT 2026 forecast reflects the **Baseline Growth Scenario (S2)**
- **High & Low Growth Scenarios (S1/S3)** illustrate the possible forecast uncertainty that may exist in key assumptions
- The Baseline Growth Scenario is denoted in visuals by a **dashed blue line**. The High & Low Growth Scenarios are denoted in visuals by a **dashed red line**

High Growth Scenario

- Optimistic ITC: Returns from 2030 – 2035 at 15%
- Low ATB cost
- Increased NEM rate (110%)

S1

Baseline Growth Scenario

- ITC reflective of 2025 policy change
- Moderate ATB cost
- Moderate NEM rate (100%)

S2

Low Growth Scenario

- ITC reflective of 2025 policy change
- High ATB cost
- Reduced NEM rate (80%)

S3

Regional PV Nameplate Capacity Growth

Forecast for all scenarios

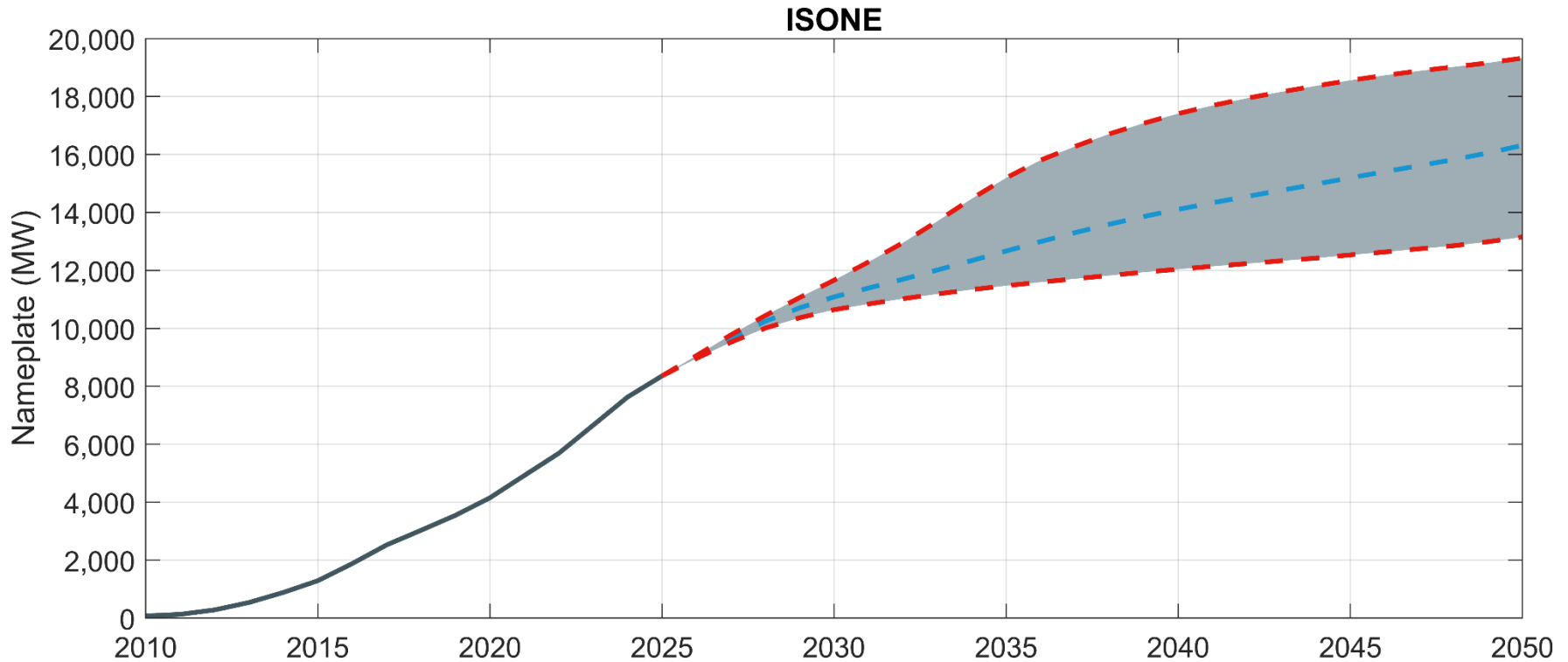

State PV Nameplate Capacity Growth

Forecast for all scenarios

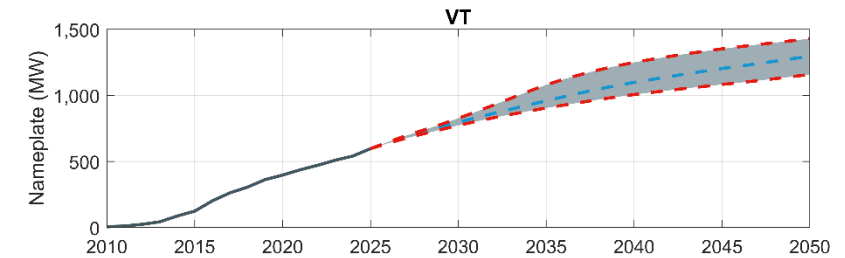
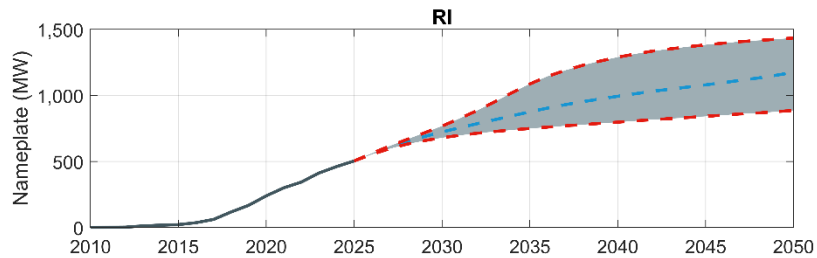
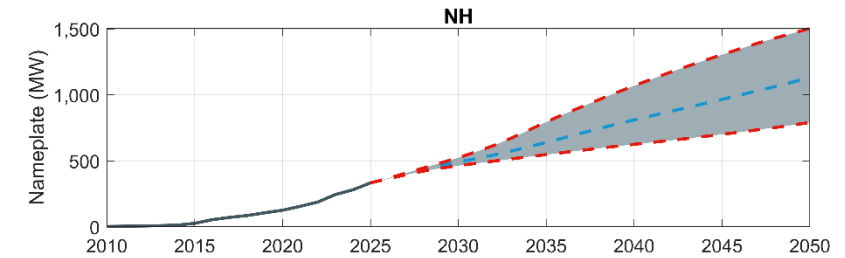
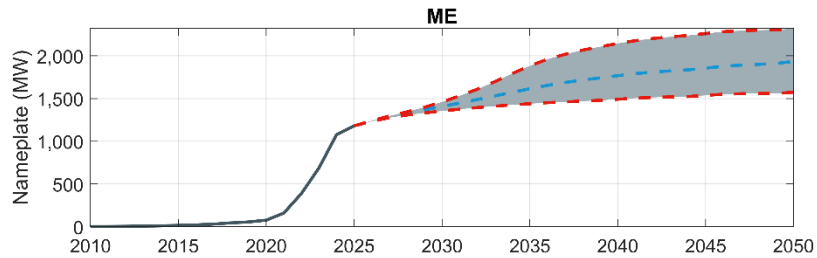
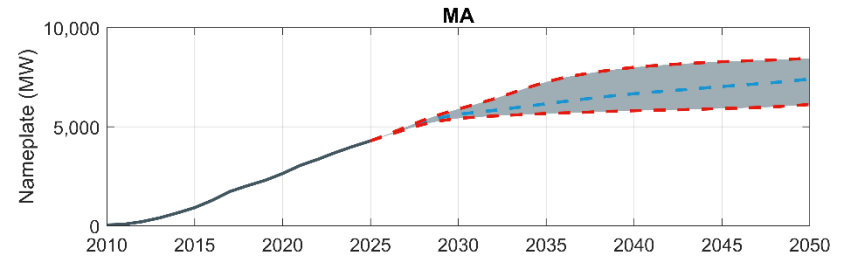
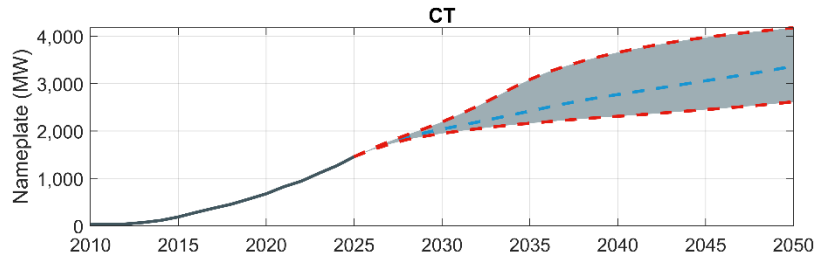

Regional BESS Nameplate Capacity Growth

Forecast for all scenarios

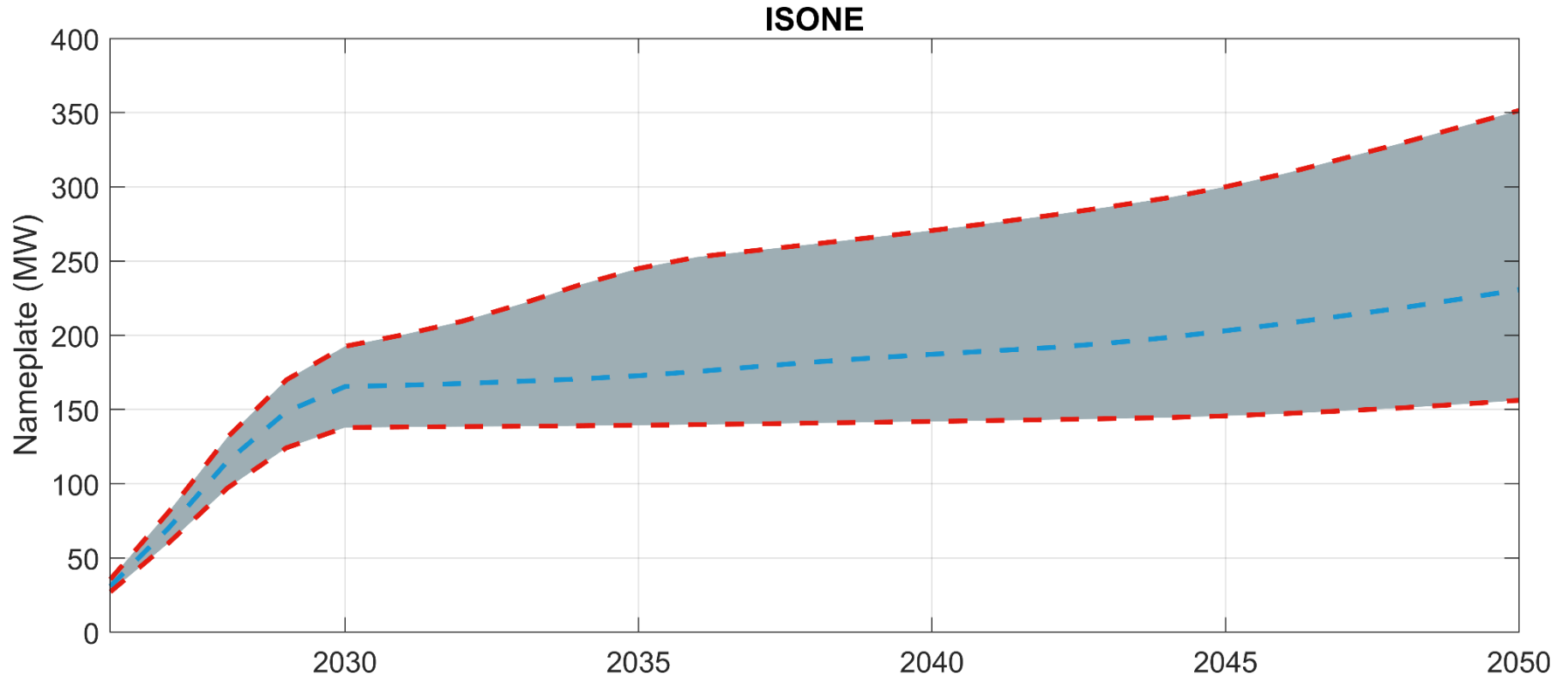

State BESS Nameplate Capacity Growth

Forecast for all scenarios

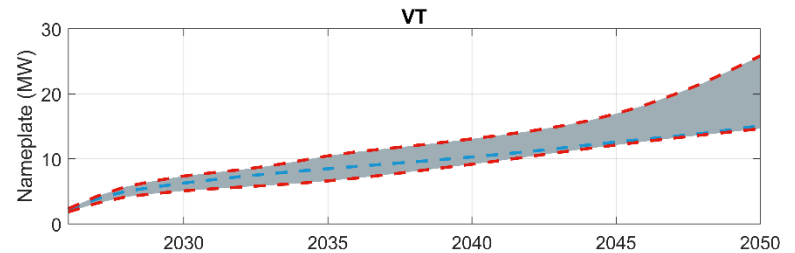
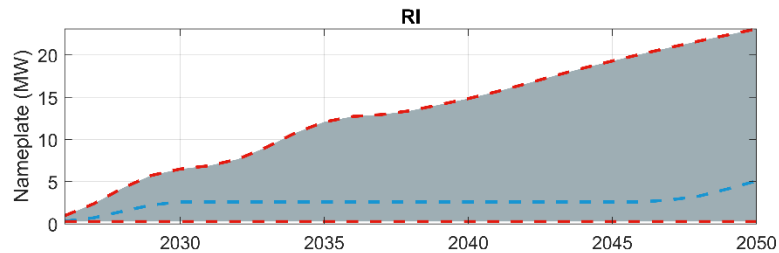
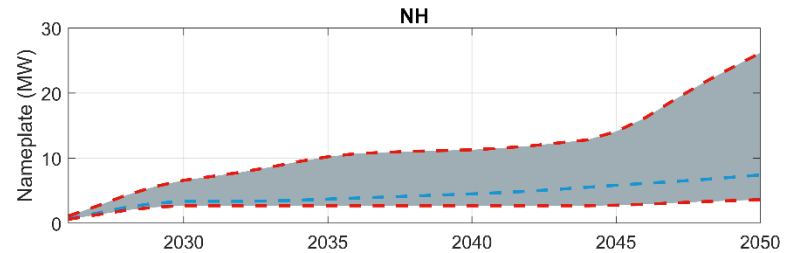
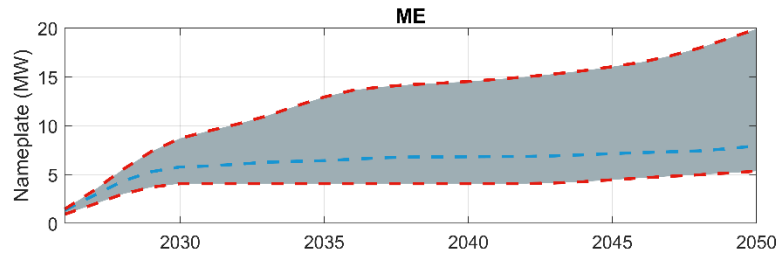
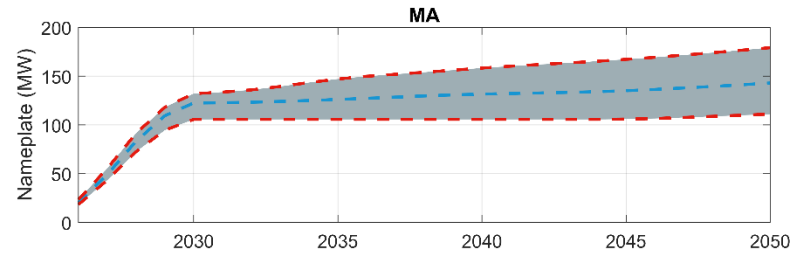
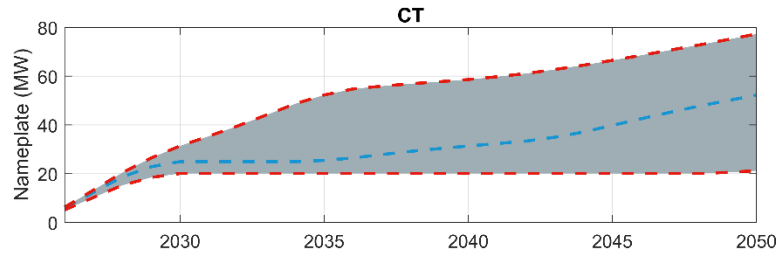

APPENDIX VI

Classification of DER Forecast – Background and Methods



DER PV Classification

All DER PV are classified into the three following mutually exclusive categories:

1. PV as a resource in the Forward Capacity Market (FCM)
 - Qualified for the FCM and have acquired capacity supply obligations
 - Size and location identified and visible to the ISO
 - May be supply or demand-side resources
2. Non-FCM Energy Only Resources (EOR) and Generators
 - ISO collects energy output
 - Participate only in the energy market
3. Behind-the-Meter (BTM) PV
 - Not in ISO Market
 - Reduces system load
 - ISO has an incomplete set of information on generator characteristics
 - ISO does not collect energy meter data, but can estimate it using other available data

DER PV Nameplate Classification By State



- Classification varies by state
 - Market disposition of PV projects can be influenced by state policies (e.g., net metering requirements)
- The following steps were used to determine PV resource types for each state over the forecast horizon:
 1. FCM
 - Identify all Generation and Demand Response FCM PV resources for each Capacity Commitment Period (CCP) through FCA 18
 2. Non-FCM EOR/Gen
 - Determine the % share of non-FCM PV participating in energy market at the end of 2025
 3. BTM
 - Net the values from steps 1 and 2 from the annual state PV forecast according to assumptions detailed on the next slide; the remainder is the BTM PV

DER PV in ISO New England Markets

Data and Assumptions

- FCM
 - ISO identified all PV generators or demand resources (DR) that have Capacity Supply Obligations (CSO) in FCM up through FCA 18
 - Maintain separate accounting for FCM_{supply} and FCM_{DR}
 - Assume aggregate total PV in FCM as of FCA 18 remains constant from 2027-2050
- Non-FCM Gen/EOR
 - ISO identified total nameplate capacity of PV in each state registered in the energy market as of 12/31/25
 - Assume the $(EOR+FCM_{\text{supply}})$ share of total PV at the end of 2025 in each state except Maine remains constant throughout the forecast horizon
 - For Maine, assume $(EOR+FCM_{\text{supply}})$ share is 40% over the forecast horizon to reflect how updated assumptions about NEB programs no longer reflect as much future MW-scale, resulting in less participation in wholesale markets than assumed in the 2025 forecast
- Other assumptions
 - FCM_{supply} PV resources operate as EOR/Gen prior to their first FCM commitment period (this has been observed in MA and RI)
 - Planned PV projects known to be $> 5 \text{ MW}_{\text{ac}}$ nameplate are assumed to trigger OP-14 requirement to register in ISO energy market as a Generator

Estimation of Hourly BTM DER For Reconstitution

- Historical BTM PV production estimates are developed at the hourly level for reconstitution in the development of the long-term load forecast
 - Estimates cover the historical period starting January 1, 2012
- The ISO estimates historical hourly BTM PV using:
 - Historical BTM PV performance data
 - Installed capacity data submitted by utilities
 - Historical energy production of market-facing PV
- BTM PV data and supporting documentation are available [here on the ISO New England website](#)
- Historical BTM BESS charging/discharging is assumed to be included in the historical load

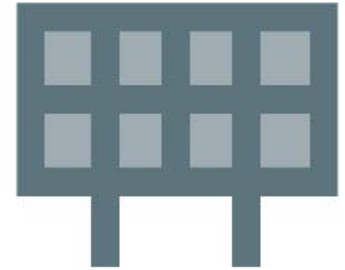

APPENDIX VII

BTM DER Energy Forecast – Background and Methods

Development of BTM PV Energy Forecast

- The BTM PV nameplate forecast reflects end-of-year values
- Energy estimates in the BTM PV forecast are inclusive of incremental growth during a given year
- ISO assumes historical BTM PV growth trends across the region are indicative of future intra-annual growth rates
 - Growth trends between 2021 and 2025 were used to estimate intra-annual incremental growth over the forecast horizon (see next slide)
- For CELT 2026, monthly derated nameplate forecasts are used with historical hourly capacity factor profiles to generate the 70 years (1/1/1953 – 10/31/2023) of hourly forecasts, for each load zone and forecast year

Historical Monthly PV Growth Trends, 2021-2025

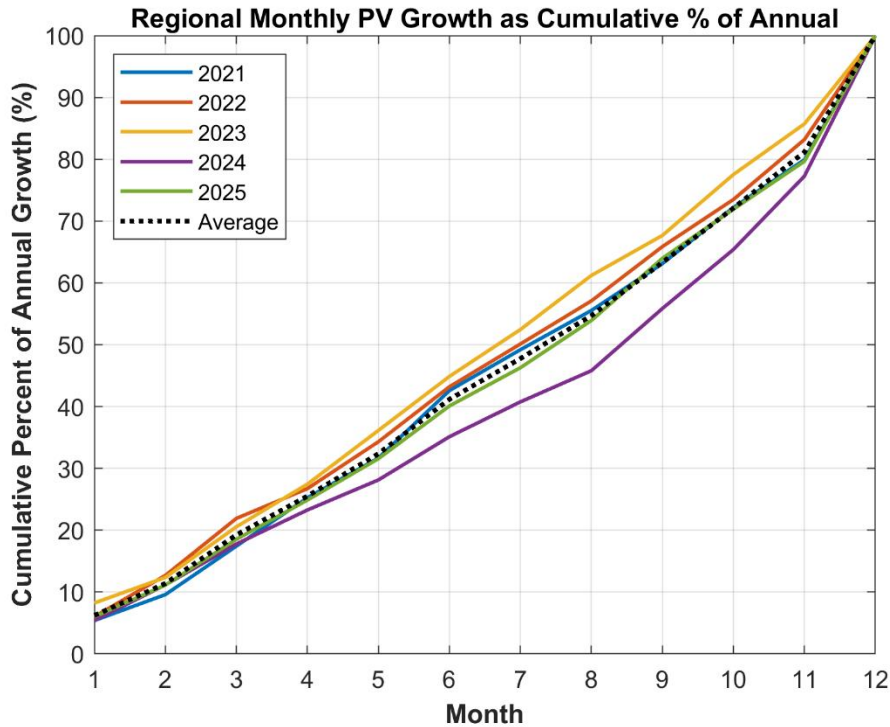

Average Monthly Growth Rates, % of Annual

Month	Monthly PV Growth (% of Annual)	Monthly PV Growth (Cumulative % of Annual)
1	6%	6%
2	5%	11%
3	8%	19%
4	7%	26%
5	6%	32%
6	9%	41%
7	7%	48%
8	7%	55%
9	8%	63%
10	9%	72%
11	9%	81%
12	19%	100%

PV Panel Degradation Factors

- No changes to the methodology to account for panel degradation were made since last year's forecast
- Forecast of BTM PV energy and summer peak load reductions include the effects of a 0.5% per year panel degradation rate to account for the expected declining conversion efficiency of solar panels over time
 - Accounting for this degradation becomes more important as the region's PV panels age
- Long-term panel degradation is often caused by:
 - Degradation of silicon or solder joints
 - Problems with the encapsulant that cause delamination, increased opacity, or water ingress
- Based on research by the NREL, the median rate of degradation is 0.5% per year, and is assumed to be linear over time
 - More information available here: <https://www.nrel.gov/pv/lifetime.html>
- The ISO estimated the capacity-weighted composite age of the forecasted PV fleet to develop appropriate degradation factors to use for the forecast

PV Panel Degradation Factors

Composite Age (left) & Degradation Factors (right) by State

- The resulting capacity-weighted, composite age of all PV in each state (left plot) and corresponding degradation factors (right plot) over the forecast horizon are plotted below
- The degradation factors assumed the percent reduction of PV performance over time that reflects the anticipated degradation of PV panels

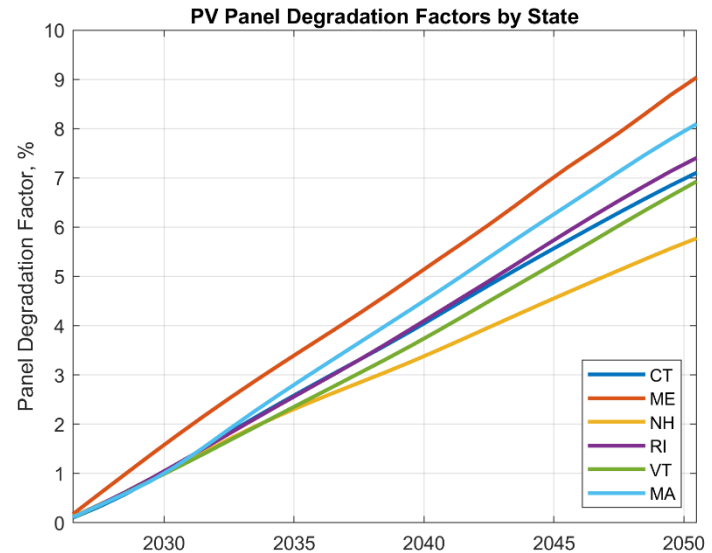
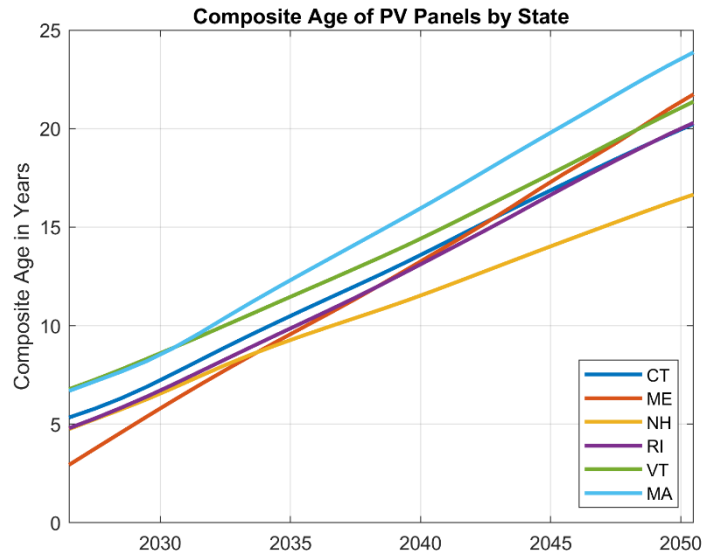

APPENDIX VIII

DER BESS Hourly Modeling Methodology



Introduction

- The ISO has developed a DER battery energy storage system (BESS) hourly profile to quantify the load forecast impacts of the DER BESS nameplate capacity forecast
 - The DER BESS forecast is a new component implemented as part of the 2026 load forecast
- As part of the ISO's load forecast methodology, the hourly BESS profiling is based on 70 years of historical weather for each year of the forecast horizon
- The following slides describe the methodology used to profile DER BESS on an hourly basis

BESS Peak Shaving

Seasonal Operating Characteristics

- The DER BESS forecast focuses exclusively on behind-the-meter (BTM) batteries that are co-located with rooftop PV, and assumed to participate in retail-based peak-shaving programs, e.g., ConnectedSolutions
 - Modeled battery behavior is generalized from existing programs to reflect impacts of peak-shaving strategies on regional peak load characteristics over time
- Battery dispatch events target reductions in coincident, system-wide seasonal peaks
 - Dispatch targets non-holiday weekdays only
- The following design features are meant to capture the imperfect foresight of retail-based programs in anticipating peak load behavior:
 - **Discharging daily hit rate:** Share of peak days dispatch correctly targets
 - Algorithm assumes dispatch will correctly targets two highest seasonal peaks
 - **Charging hourly hit rate:** Share of lowest load hours dispatch correctly targets

Season	Months	Discharge				Charge	
		# events	Duration	Hit Rate - Daily	Target Hours	Target Hours	Hit Rate - Hourly
Winter	Dec, Jan, Feb	30	3	80%	3 highest seasonal peak hours	6 lowest load hours in 21 hours after dispatch	60%
Spring	Mar, Apr, May	10	3	80%	3 highest seasonal peak hours	6 lowest load hours in 21 hours after dispatch	60%
Summer	Jun, Jul, Aug	30	3	80%	3 highest seasonal peak hours	6 lowest load hours in 21 hours after dispatch	60%
Fall	Sep, Oct, Nov	10	3	80%	3 highest seasonal peak hours	6 lowest load hours in 21 hours after dispatch	60%

BESS Profiling - Inputs

Aggregate energy capacity

Defined by assumed 2.5 hour duration

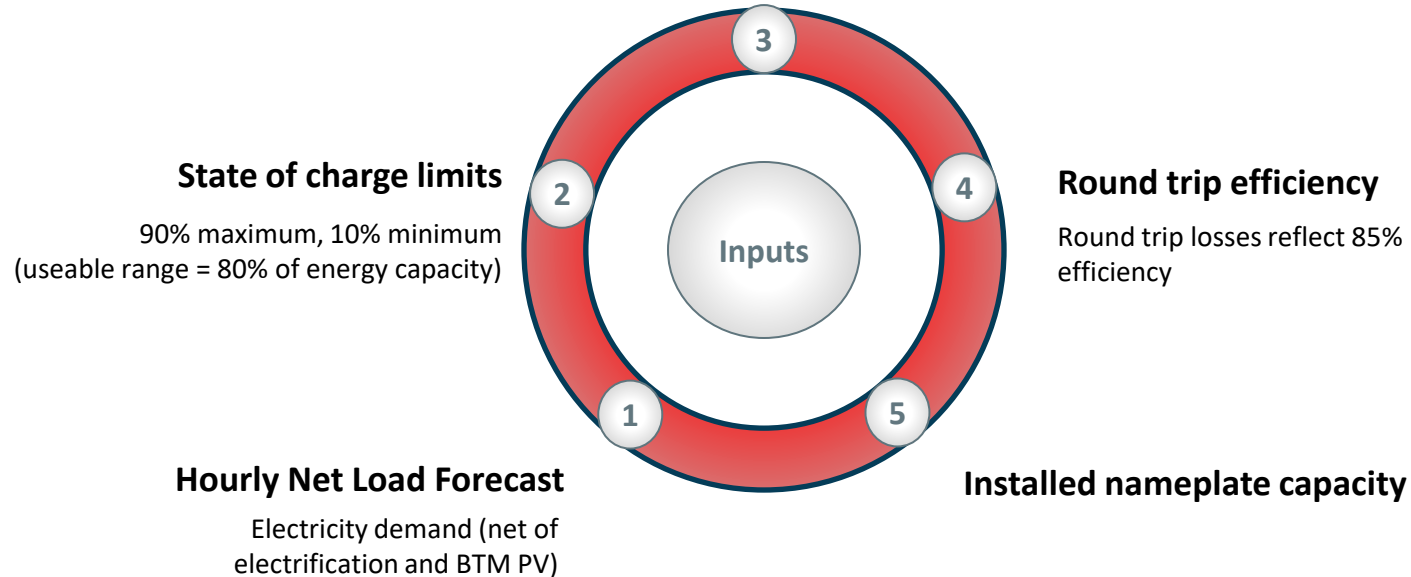

BESS Profiling - Assumptions

- For each dispatch event:
 - BESS is assumed to start at 90% charge, and discharges until a 10% state of charge
 - BESS charging occurs until a 90% charge is again reached
- Charging can happen on either daylight or non-daylight hours (both from grid or from DER PV)
- Available charge energy is distributed evenly to each hour in a discharge window (3 hours)
 - $Hourly\ Discharge = \frac{nameplate \times battery\ duration \times usable\ range}{number\ of\ discharging\ hours}$
- Required charging is distributed evenly to each charging hour
 - $Hourly\ Charge = \frac{total\ discharge}{round\ trip\ losses * number\ of\ charging\ hours}$

Seasonal Peak Event Selection

Example for the Summer 1954 in Forecast Year 2040

Date	Time	ISO-NE Peak Net Load (MW)	
8/25/1954	19:00	24,330	1
6/21/1954	18:00	23,191	2
7/13/1954	19:00	22,858	3
6/22/1954	18:00	22,325	4
6/25/1954	19:00	22,118	5

Date	Time	ISO-NE Peak Net Load (MW)	
8/25/1954	19:00	24,330	1
6/21/1954	18:00	23,191	2
7/13/1954	19:00	22,858	3
8/3/1954	19:00	18,591	4
6/25/1954	19:00	22,118	5

1

ISO-NE peak net load hours are sorted from highest to lowest

2

Missed peaks (#4) are stochastically selected to model imperfect foresight

Dispatch events are determined using the seasonal peak load hours

- Informed by the 70-year hourly net load forecasts of the 2 years prior*

The frequency of misses is defined by the daily "hit rate" (80% hit rate = 1 out of 5 peaks missed)

Discharging Logic

Example for Forecast Year 2040

- Peak hours are defined as the three contiguous hours with greatest share of highest seasonal peaks
 - Highest peak occurred most often on Hour 17-19
- Discharging (**D**) is allocated equally to the 3 dischargeable hours of each dispatch day

Date	Time	ISO-NE Peak Net Load (MW)	
8/25/1954	19:00	24,330	D
6/21/1954	18:00	23,191	D
7/13/1954	19:00	22,858	D
8/3/1954	19:00	18,591	D
6/25/1954	19:00	22,118	D

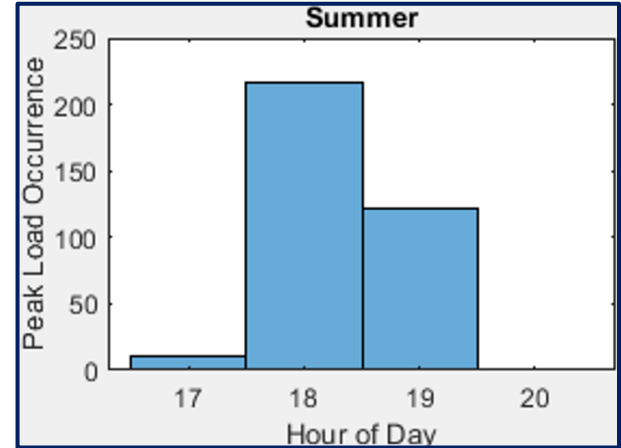

Discharge hours are defined as
Hours 17-19

Charging Logic

Example for Forecast Year 2040

Date	Time	ISO-NE Peak Net Load (MW)	
8/26/1954	3:00	14,107	1
	4:00	14,206	2
	12:00	14,271	3
	13:00	14,301	4
	2:00	14,479	5
	5:00	14,960	6
	11:00	15,213	7
	1:00	15,360	8
	14:00	15,450	9
	5:00	16,170	10

Date	Time	ISO-NE Peak Net Load (MW)	
8/26/1954	3:00	14,107	C
	4:00	14,206	
	12:00	14,271	
	13:00	14,301	
	2:00	14,479	C
	5:00	14,960	C
	11:00	15,213	C
	1:00	15,360	C
	14:00	15,450	
	5:00	16,170	C

1 The 10 hours with lowest loads in the 21 hours following a dispatch event are identified

Discharge event: 8/25/1954, Hours 17-19

2 Charging hours (C) are stochastically selected and the load divided equally across each hour

The number of charging hours is defined by the hourly "hit rate" (60% hit rate = 6 out of 10 hours)

Example of BESS Operation

2014-2015 Hourly Results, Forecast Year 2040

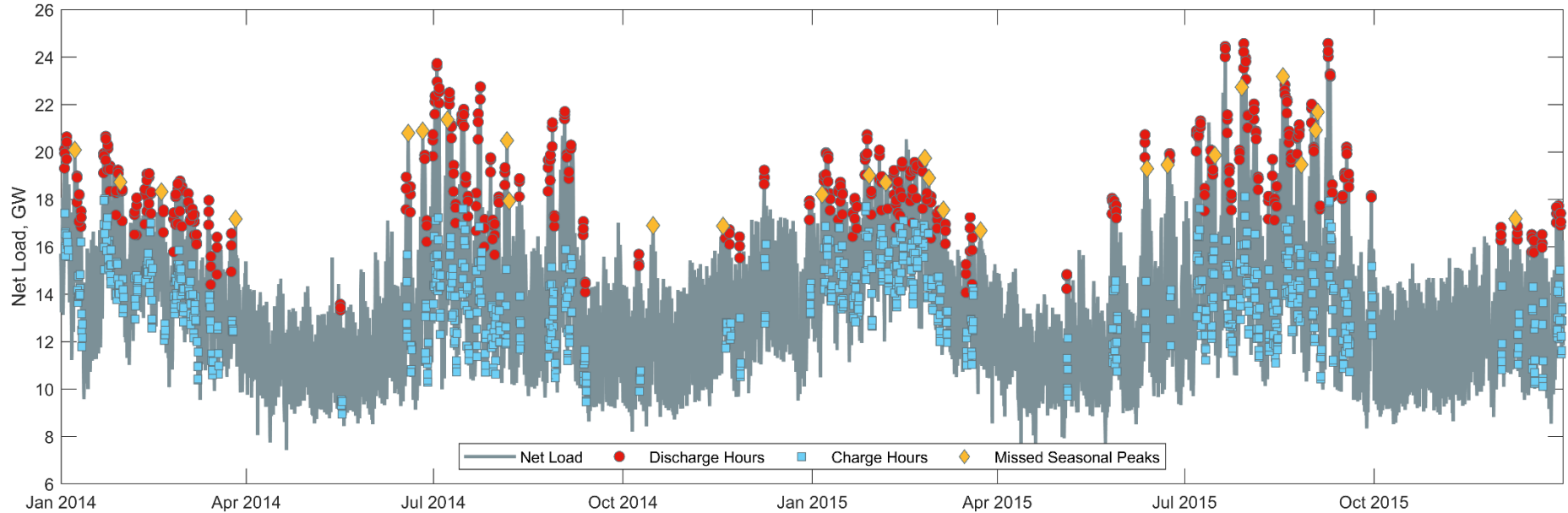

Example of CT BESS Operation

August 2018 Hourly Results, Forecast Year 2040

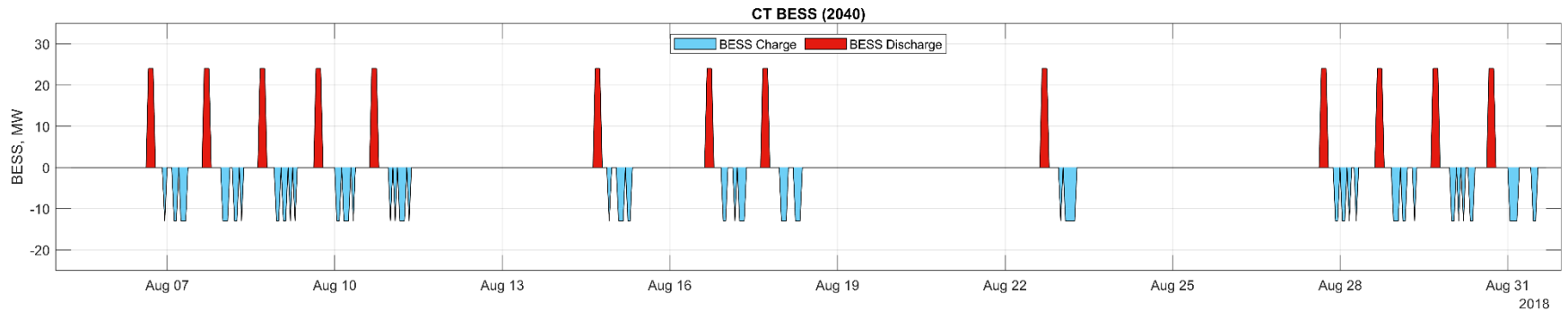
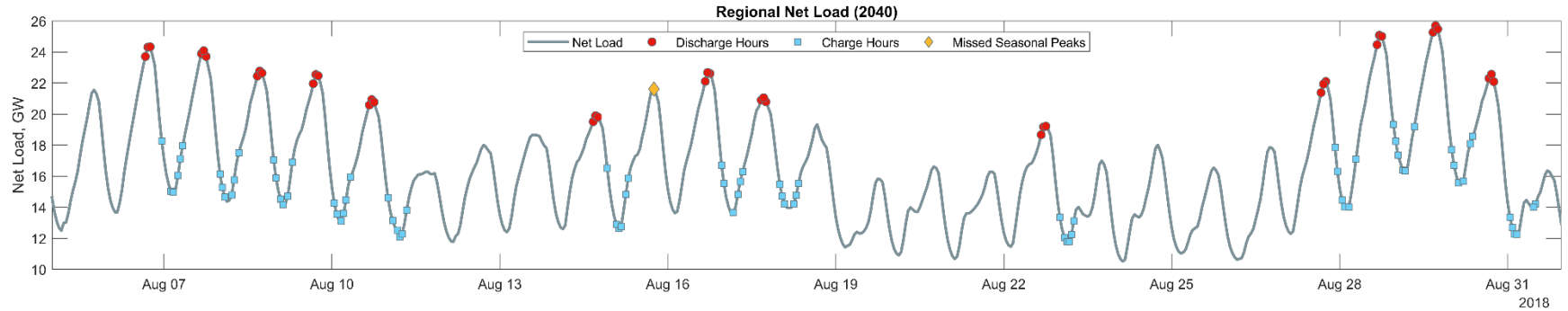

APPENDIX IX

DER PV End-of-life Accounting



Introduction

- The lifespan of PV systems is affected by numerous factors, including, but not limited to:
 - Time to failure of components (inverters, panels, balance of system)
 - Roof replacement, building renovations or demolition
- When DER PV reaches end-of-life, system owners decide whether to repower or retire the system
 - Repower: System or individual components are replaced/refurbished for continued use
 - Retire: System is decommissioned and will no longer be in service
- The PV forecast reflects newly adopted DER PV, but does not consider the impact of future end-of-life turnover
- As the region's DER PV fleet continues to age, a growing number of systems will begin reaching end-of-life and increasingly impact future cumulative amounts of DER over time

DER PV End-of-life Accounting

- The ISO developed a methodology to account for DER PV systems that reach the end of their useful lives and are retired
- The retired DER PV nameplate capacity was calculated based on projections of cumulative end-of-life capacity using a set of lifespan assumptions, and an assumed portion of end-of-life DER PV nameplate that would be retired rather than repowered
- The 2026 DER PV nameplate capacity forecast considered the impact of all retired DER PV systems resulting from this accounting

Estimated End-of-Life Turnover

- Based on historical and forecast growth reflected in the 2026 DER PV forecast, simple projections of cumulative end-of-life capacity are illustrated based on different assumed lifespans of a PV system
 - Inverters have a typical lifespan of 15 years
 - PV panels can have a lifespan of 30 years or longer, but produce less power over time

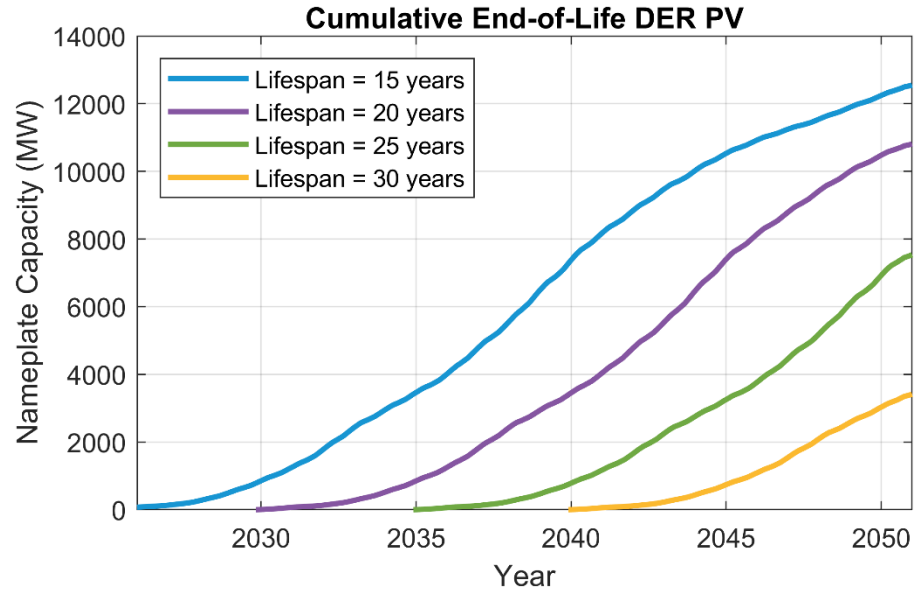

Accounting for PV End-of-Life

- The ISO has developed the following initial assumptions to account for end-of-life system turnover in the 2026 forecast
 - Systems will reach end-of-life according to a variety of lifespans ranging from 15-30 years
 - 75% likelihood for system repowering, 25% likelihood for retirement

Lifespan (years)	Lifespan Likelihood (%)	Retirement Likelihood (%)
15	10	25
20	20	25
25	35	25
30	35	25

Estimated Cumulative Retired Capacity

CELT 2026

- Based on the assumptions outlined on the previous slide, a projection of cumulative DER PV estimated to be retired due to end-of-life decision-making is illustrated for CELT 2026
- Retired capacity is subtracted from the adoption forecast to reflect anticipated end-of-life turnover

